

INSIDE HP: A NARRATIVE HISTORY OF HEWLETT-PACKARD FROM 1939–1990

by John Minck

Introduction

I started writing some parts of this back in the early 1980's, because I felt that it might be useful for new employees of HP (and later Agilent) to know more about the early culture of "our" company. During my 37 years with HP, I had always felt very privileged to have been offered employment here in 1957. Immodestly, this narrative contains a lot of personal experiences and even some non-HP stories of my life and times, although my *Life and Times* life narrative is another long document. When you finish reading all of this you may think I should have sub-titled it "Hewlett-Packard and Me."

Leading up to the 1980's, the company had reached some growth years when we hired thousands of new employees each year, with perhaps hundreds of them as engineers and field sales people. As I gave orientation lectures to new employees in our Stanford Park Division, on how our customers used our equipment, or to neophyte field sales engineers from all over the world, I found a tremendous interest in the company's past history. I often led auto trips down to Dave and Bill's first garage on Addison Avenue, in downtown Palo Alto.

By the 1980's, Hewlett-Packard had become a business phenomenon. The company's external success and its internal workings had caught the fancy of the nation's business press, as well as the popular Bay Area press. Management texts and conferences began to contain frequent references to HP's organizational and business strategies and tactics. Tom Peter's 1982 book, *In Search of Excellence*, gave high marks to HP for our ability to organize and to innovate, both in products and our work culture.

All of us who worked at HP in those years had become very proud of this recognition. It was a great ego-booster, to belong to a winning team, and HP was a winner, in products and profits and performance.

But, in 1985, HP was a lot more than a successful multi-national corporation, with over 82,000 people, hundreds, perhaps thousands of buildings, and more than 1000 acres of floor space under roof. It was the place where we employees spent about a third of our waking hours. And next to our family and friends, HP was often the most important thing in our lives. For some, it may actually have been THE most important thing.

I recall a late evening in the early 1960's, I was working on some midnight project, in Bldg 5U, and using the copying machine, when I ran into Carl Anderson. At that time, Carl was managing some corporate promotion and catalog functions. "Go home, Carl!" I said, and he answered, "I am home; once in a while, I go to my house." (When I retired in 1995, I remember explaining to my friends that I was feeling pretty-much adrift--not having any hobbies to fall back on--since, in a real sense, "I am what I do.")

That's the whole point to this monograph. The HP Company culture, down at the people level, has been mentioned positively in most of the flattering articles about us. The management philosophy coined by Bill Hewlett or Dave Packard, "*The HP Way*," has been described and analyzed a lot over the years. Those many industry authors would analyze our processes and organizational details of how we worked with each other in a spirit of openness and cooperation.

My memories are rich and full. I've visited hundreds of customer plants in my 37 years with HP, and have probably talked with a thousand customers in their workplaces as well as at trade shows and conferences. In those discussions, a lot comes out about the working cultures in those other companies. What I found was that there are almost no workplaces that matched HP in overall friendliness and spirit and personal relationships. I could walk down to the desk of a lab engineer, and ask for a half hour of microwave tutorial to help solve a customer problem. There would be no hesitation, nor would they worry about someone stealing credit for something they created. There were many companies I visited, where engineers held everything technical very close to their office, since there were so many cases where others would steal their clever ideas as their own.

But, in the 1990's, that very style of openness (and of course, the business acumen) that had created our successes threatened to bury us in a continuing growth that might have overwhelmed the personal "feel" of the company we once were. By the time of the spinoff of the Agilent product line, HP had become a giant, powerful, and imposing corporation.

For the tens of thousands of new employees who have joined HP and Agilent in the recent years, from a worldwide diversity of cultures, I felt that this story about some of the early HP personalities would be interesting, as well as perhaps useful. By meeting some of these engaging personalities, we could see that the present HP/Agilent business culture has its roots in a long line of HP employees.

Like any shared human endeavor, these early characters are diverse and interesting. All the human strengths and weaknesses are there, but there is a good-nature to them. They get along. They work as a team. They have fun working together. There is no caution or distrust in dealing with each other.

With the spinoff of Agilent Technologies, of the Test and Measurement, Health and Chemical sectors in 1999, we hoped that most of the early HP culture would transfer to the new entity. But surely, as the HP corporation continues to branch further into computer, PC and Internet cultures, some sense of its HP Way roots will remain, just as do some thousands of senior employees who have stayed with the computer part of HP. Even as the Compaq merger consolidation goes forward, the HP Way will metamorphose, to guide the company that Bill and Dave founded. I believe

that this is a living culture that must be preserved and nurtured, as HP and Agilent move ahead.

I've lived the HP Way through more than half of HP's history, from my first day on Jan 2, 1958, just after the Russian Sputnik went into orbit. My entry into the company happened mostly by chance, which is the way a lot of things work in life. During my engineering courses at the University of Notre Dame, in 1948-52, I used HP equipment in the various student laboratories.

In 1951, at my first engineering summer job at General Electric Company in Syracuse, NY, I used more HP RF/microwave gear in radar system testing as a summer test engineer. Then, in 1952, as a blast line instrumentation engineer at Sandia Corporation, working on full-scale atomic bomb tests, in Nevada and Eniwetok Atoll, almost all our equipment was HP.

So I was well introduced to HP's test equipment quality and performance as I entered Stanford University in 1956, for my MSEE/Admin degree. One of our Stanford class trips during that business course was to HP's headquarters at 395 Page Mill Rd. My lasting impression of that plant visit was the hundreds of HP 608 signal generators, sitting on burn-in racks in the production area. Although I had seen massive television set production at GE, Syracuse, years before, I still pondered over who were all those hundreds of customers who would buy all those rather specialized HP signal generators?

There were just about 1500 employees when I hired on in 1958, and annual revenues were \$25 million. After learning that in the year I graduated (1952), HP revenues had been only \$10 million, I recall thinking that I had missed my big chance to join a "growth" company, 5 years before, because all the growth in this company has already happened! Let's see, after that, HP grew from \$25 million to \$70 billion, in those 36 years, which is a factor of 2800. Guess I didn't really miss the growth. I believe it was Barney Oliver, who observed during one lecture that if money was power, he could then treat financial ratios as decibels. So, in this case HP had grown 33.44 dB in my decades with HP.

Yet, I was so happy to be there in 1958. The salary offer of \$625 per month plus bonus was respectable, in the business recession of 1957, and my second child was just about to be born. Life was good. By the way, HP's salary bonus system of that day had progressed to the point, where the bi-monthly salary bonus was just at 30%, having been based on some calculations about 10 years before. The percent factor was soon adjusted downward with a one-time increase in the base salary.

Most of this material, I'm writing about, was experienced by me directly, while some is HP lore, handed down from old timers, to us newcomers. The narrative is necessarily focused on the microwave and LED areas of the company, where I spent most of my career. That doesn't mean that the hundreds of other HP people and products and operations were less important, but only that I didn't live through them. I've also related the "inside" stories of many of HP's older and interesting products.

As you will see, although I have titled the narrative as the years from 1939 to 1990, the emphasis is on the earlier parts of the company. I occasionally mention organizational matters and product lines from the 90's and even the 21st century. But I think my expertise and knowledge is better from those earlier periods. When it comes to CEO Fiorina's decisions to acquire Compaq, I will leave that to people better informed and knowledgeable than myself.

I also leave out those parts of this successful corporation from the medical or chemical arenas. These groups had highly innovative products which gave major accomplishments to the world. All the HP strategies in the big system world of servers and PCs and the huge revenues of the printer groups are not in my realm, to even comment. Such product lines were truly big-time, rivaling even the major players like IBM and others who ruled those business sectors in previous decades. Yet HP's products and marketing allowed our favorite corporation to stand in there and compete vigorously. They involved huge global sales deals with many national governments—just like the IBM colossus we always admired. For this old naïve farm boy from Ohio, that is impressive indeed.

••••••••

The Early Years

The really interesting thing about having a corporate history so young, is that most of the buildings and places and many of the people are still right there to see. When you come to Palo Alto, you can easily drive past the "first garage" at 367 Addison Ave. It's still there, and it looks much like the well-published picture every HP person has seen in their orientation slides and history brochures.

In 1987, the Addison street garage was declared a California Historical Landmark, assuring that it cannot be removed or changed. During HP's 50th year anniversary celebrations, in 1989, a large bronze plaque was installed in front of the lot where the garage stands. Finally, a couple of years ago, when the house came on the real estate market, HP company purchased the home and garage and lot for company preservation. The sales price was staggering, something like \$1.7 million, as was most Palo Alto real estate. But it was well worth it, since the "new" HP had assumed some strong promotional positions based on the "The Garage."

Of course, in the last years of the great 1930's depression, that garage housed only a fragile partnership, with an experimental bench and some dreams that there would be some customers out there who would want to buy a few of Bill's novel RC audio oscillators. As it would turn out, there were plenty of people, including the Chief Engineer of Walt Disney Productions, who, in 1939, needed a number of audio oscillators to test the audio performance of the sound systems of the theatres showing their new movie *Fantasia*, which had many new sound effects.

I recently came across an interesting sidelight to Hewlett's thesis oscillator design. It was about HP's main competitor of the time, General Radio Corp, which had been in business for several decades before HP. It was well known that GR offered

the “Cadillacs” of the audio oscillators of the time. They were called beat-frequency-oscillators (BFOs), and were considerably more expensive than the HP 200A (\$695 vs. \$70). In the product section for the HP 200CD, later in this narrative, I have included some verbatim quotes of the failure of GR to capitalize on their RC technology, and the subsequent takeover of the market by HP.

In this 2006 revision, I decided to attach an appendix of a chapter from one of three Oral Histories of Fred Terman, Dave and Bill’s professor/mentor at Stanford. I stumbled upon it in some research at Stanford’s library, and was stunned at just how significant Terman was to Dave and Bill’s success, during those just-terrible years of the depression 1930s. Terman also credits the founder of General Radio, Melville Eastham, for early business advice to Dave and Bill.

By 1940, the technology of radio had been booming for some decades, from the 1920’s and 1930’s. The technology of “electronics” itself was blossoming. In fact, only 10 years before, in 1930, Publisher McGraw-Hill had coined the term “electronics,” and created a new magazine with that name. I still have a 35th-year commemorative issue of *Electronics*, from 1965, which reprinted a lot of the April, 1930 inaugural issue.

Dave and Bill soon moved from Addison to the "Tinkerbell" buildings, located at the corner of El Camino and Page Mill Rd, opposite Palo Alto Square. The front building was a repair shop owned by a man named (ready for this?) Bell. In 2006, it was a cellular telephone store, and the HP #2 garage in back (481 Page Mill) was, ironically, first a TV/VCR repair shop and now a GPS products store. This picture below, shows the rear building as HP, circa 1942.

During the early WWII, HP expanded into both buildings. In about 1943, needing more space, they built the Redwood building one block over at 395 Page Mill on the corner of Ash. They continued to use the Tinker Bell buildings for fab operations until after the war. At that point, the Polly & Jake antique shop moved from downtown. One confusing point to all this was that the store front for P&J had a slogan which stated, “From 1929.” My previous impression was that HP had only used the rear building, but this new information was



The original Polly & Jake Garage

supplied by Cort van Rensselaer, who was a part-time technician while at Stanford, before he joined the US Navy. Also, I talked with Ray Rooney and Norm Schrock who were both employed in those years.



The Redwood Building

In 2009, both of those early P&J buildings found the same fate as the entire block of HP Bldgs 7A, B, C, 8 and 12 when Agilent built their WW headquarters at 295 Page Mill. The big JAWS came to that corner, and demolished both buildings, so that they could be replaced with a 3-story office building.



Bye, Bye, Polly & Jake

In the 1940’s, Page Mill was a gravel road leading to a grade crossing at the Southern Pacific Railroad tracks, 2 blocks east, alongside Alma Street. To the westward, Page Mill Rd. snaked across the foothills and the coastal mountain range to the ocean. It had served as a logging road for redwood lumbering, in earlier decades at the turn of the 20th century.

The earliest years of the HP company focused mostly on simple sheet metal fabrication, and assembly with "radio" parts; capacitors, vacuum tubes, resistors, and other mechanical parts. The two most distinguishing trademarks of the first product, the HP 200A Audio Oscillator, were the tunable resistance-capacitance bridge network, and the 7.5-watt candelabra lamp. A ganged, variable-air (radio) capacitor tuned the 180 degree phase-shift bridge, which supplied the oscillator’s positive feedback. A positive-coefficient lamp served as the novel negative feedback in the oscillator vacuum tube cathode circuit, to keep the output power stable.

A Minck digression. In my relatively long life, I have observed that there are a certain number of unexplained coincidences in most person's lives. During the 1956-57 time of my MSEE/Adm degree work at Stanford University, I was spending a quiet afternoon, studying in a small conference room in the Electrical Engineering building (which, by the way had been donated early on by Dave and Bill). It happened to have a large shelved cabinet, which held some hundreds of graduate theses. In browsing among them, I picked up a very thin one, maybe 20 pages, which turned out to be the Bill Hewlett thesis on the HP 200A.

As mentioned above, I had worked with a lot of HP equipment before my term at Stanford. In that conference room, I had no intent to ever go to work at HP. But I do remember being struck with the simple observation that one could seemingly get by with a pretty simple idea for meeting the Engineer Degree thesis requirement at Stanford. At Stanford, the Engineer Degree was a rank between their MS and PhD, and was Bill Hewlett's graduate program.

One reason I had chosen Stanford's combined MS engineering and business school curriculum (MSEE/ADM) instead of pure engineering, was that I didn't like the idea of working long and hard on an engineering thesis. But I wanted some technical instead of pure Graduate School of Business, since as I graduated from Notre Dame (ND) in 1952, we barely had any coursework on semiconductors, the transistor having just been invented in 1948. I felt that more recent semiconductor coursework would be valuable to my resume, although I have admitted on many occasions, that I hardly ever did any honest engineering work in my entire life.

The 35 hours in the GSB were invaluable; business law, economics, accounting, etc. Looking back, I think I made the right decision in getting the combination. I always loved the technical but found the business knowledge to be important. Plus the two Business Law courses by the legendary Harry Rathbun were perhaps my best courses of all time. And then there was the bombastic Economics Professor, Theodore Kreps, who was a member of Roosevelt's Washington brain trust during the depression, who would rail at us "you Republican sons of big businessmen.

The second great coincidence of my life had nothing to do with HP, but I'll bore you with it anyway. It did influence my coming West from my home in Ohio, and my university years at Notre Dame, Indiana. In 1952, as we were ready to graduate, the Korean War was in full swing, so EE graduates were in great demand. I think I interviewed and had 20 job offers.

Actually I was leaning toward a job with General Radio Company in Cambridge, Massachusetts (the same competitor mentioned above). The reason was that during my Junior and Senior year at ND, I was editor of the student engineering publication, the *Notre Dame Technical Review*, and found that I enjoyed technical writing and editing. This was true even though I had been abruptly thrown into the job as a Junior, a month after I joined the magazine, and just after I had submitted an article for publication. The editor had left school for family reasons, and the Dean called me in and appointed me.

General Radio offered me a job as an editor for the *GR Experimenter*, their industry publication, (their version of the *HP Journal*). The work sounded pretty interesting, and I would get paid for writing. In my later life, I am surprised that I would have even considered Boston, because, in my HP travels, I came to dislike that provincial city a lot. It was those freeways that ended abruptly on city streets and its unfriendly "rotary" traffic circles, that purported to move traffic expeditiously in their busy urban streets, without using stoplights. They were much like the "roundabouts" in the UK.

I had also interviewed the Sandia Corporation on the campus, and was expecting a trip offer to Albuquerque, but none came. A classmate soon told me that he was taking his interview trip there, so I asked him to try to find out what happened to my resume and the trip offer I expected. On the day of his visit, Sandia's recruiting manager called me and said that they had misplaced my resume, but they had found it and were sending me an airline ticket immediately, and to please visit ASAP.

About a week later, on a typical Midwest February day, I was flying out of Midway Airport in Chicago, with a temperature of -10 degrees, and blowing snow flurries. We flew that old TWA Constellation into Albuquerque, and I stepped off the stairway into a sunny temperature of 90 degrees. I said to myself, "If they make me an offer, they've got me." They did, and I did and that decision took this naïve Ohio farm boy part way West.

Another turning point. In 1956, as I was leaving my USAF duty in Texas, I was trying to choose between acceptances from MIT, Stanford, Berkeley, and Cal Tech for graduate school. Again, inexplicably, I was strongly considering MIT and Boston. My next-door neighbor, an air force flight surgeon from San Pedro, CA, simply told me that if I went anywhere but Stanford, I would never forgive myself. Which is what brought Jane and me the rest of the way, to the Far West, and to the city where we would spend the rest of our lives. Life sometimes seems to hinge on such events, which seem trivial at the time, but end up influencing one's whole life. I have never regretted either decision, and further, I feel so privileged to have lived here in the Bay Area of California.

WWII days. In 1943, Bill Hewlett went into the Army Signal Corps for service at the Pentagon, on military countermeasures projects. Dave remained at Palo Alto, running the fledgling company and producing considerable quantities of war goods. In the process, they earned 2 U.S. War Production Office "Excellence" awards for efficiency in the industrial war effort. Of course, the HP 200A Oscillators, being inexpensive and highly reliable, served a critical war need, in applications ranging from tone generation for Morse-code training to signal testing applications in electronic design labs coast to coast.

A 1984 book, *"The History of US Electronic Warfare in WWII,"* shows an early HP 200A oscillator mounted on an operator shelf in an airborne application. The program required the plane to fly over enemy territory and analyze the parameters of the threat radar signals. That airborne "countermeasures" equipment came from the legendary Radio Research Lab at Harvard, managed by the equally famous Dr.

Frederick Terman. Terman is also credited with creating the concept of the modern (Stanford) industrial park, and in turn "Silicon Valley."

Some people might remember that the Radiation Laboratory at MIT was responsible for radar design and production during WWII. In recruiting for engineering talent, the "Rad Lab" tended to find East Coast personnel, whom they knew from personal contacts.

When Roosevelt's Science Advisor, Dr. Vannevar Bush, was ready to set up a complementary lab for Electronic Countermeasures, he established it at Harvard University. He named it the Radio Research Laboratory, and chose Dr. Fred Terman, of Stanford University to head it up. Part of his reasoning was that Terman would have access to a whole different engineering talent pool from West Coast universities and industry. Bush had gotten to know Terman well when Fred was elected to the presidency of the IEEE in the late 1930's. (See the Terman Appendix at the end.)

One must remember that engineering talent for the war effort was concurrently being depleted by massive recruiting for the Manhattan Project. This program drew large groups of scientists for the atom bomb work at Los Alamos, NM, Oak Ridge, TN, and other sites around the country.

When Terman returned to Stanford after the close of WWII hostilities, it was his idea that great advantages would flow from a close technical relationship between Stanford's academic pursuits and the practical experience of modern industrial practices. It was Terman who conceived the idea of convincing Stanford University to lease some of its rural land, which became the world-famous Stanford Industrial Park. Terman also served for many years on the HP Board of Directors

Varian, Lockheed and Kodak were early tenants of the Park, and HP moved up to the "hill" complex at 1501 Page Mill Rd., in about 1957. I remember that, because when I showed up on Jan 2, 1958, for my first day on the job at Bldg. 9, the office building at Page Mill and Birch, I was told that they had used the new empty buildings 1 & 2 on the hill for their Christmas party, a week before.

Dick Rucker observed: "I think I was there! As I recall it, the lab area had no furniture in it yet and the floor was still bare concrete. For the party, there were folding tables and chairs set up, lots of bubbly and cake, and music for dancing in that large unobstructed room."

"A long table or two for serving the champagne and such were set up on the east end of the room. It was from there that Dave handed out the year-end bonus checks. I remember being pleasantly surprised at receiving such a generous bonus since I had only been there just a few months."

At that time, Page Mill Rd was a grade crossing over the Southern Pacific railroad tracks that ran along Alma Street. The convenient Page Mill/Oregon Street underpass came many years later.

Another personal coincidence was the row of apartments

running along Alma. When Jane and I came to Palo Alto for Stanford in 1956, we left an inexpensive military housing situation in Texas. We had not the slightest concept of the dire housing availability here in the Palo Alto area. Day after day, we waited for the *Palo Alto Times* to publish, looking up apartment rental ads, and rushing out to those places, but it wasn't working. Jane was 7 months pregnant, and it was seemingly hopeless. Then, Jane insisted that we just drive to the Alma Street apartment district and hit the bricks, walking from apartment to apartment, asking for an opening. Sure enough, in less than an hour, we learned that a neighbor was leaving, and we were able to commit to a place to live. Another life lesson there, listen to your wife.

Our apartment was there on Alma Street, right at the Page Mill intersection. I remember it well, because there was also a concrete-mixing plant at the intersection. At midnight, the Southern Pacific railroad would deliver rail cars full of sand and gravel and cement to the plant. As the switch engine shuttled the cars around, the Page Mill street crossing gates would come down for about 30 minutes, with the crossing bells loudly sounding. With a brand new baby, that didn't help her sleep, or ours.

That first apartment was one block from the company where I would spend a lot of my life, but I didn't know it yet. I used to joke that the switch engine had one square wheel, since it seemed like there was a lot of track and wheel noise, in addition to the clanging warning gate. For the following academic half-year, we were able to rent a really cheap (\$55 per month) apartment at Stanford Village. It was a married student housing arrangement using converted barracks from the old WWII Dibble Army Hospital in Menlo Park. Jane used to tell me that when she would go over to the adjacent laundry room, she could call out to our neighbor through the "cardboard" walls that she would be back in 5 minutes.

HP, Circa 1940

HP historical archive photos show a fabrication floor at the Tinkerbell building, at Page Mill Rd. and El Camino, consisting of Sears-Roebuck drill presses and standard hand-operated hole punchers and metal "brakes" for bending the sheet metal chassis. Cabinets for the HP 200A were purchased ready-made from the Bud Company, which was well-known as a radio-experimenter parts supply company. Many of these early company details are described in Dave Packard's book, *"The HP Way, How Bill Hewlett and I Built our Company."*

The front panels of the oscillators, of course, had to be custom fabricated, since the oscillator knobs of frequency range and power needed special custom calibrations and engraving. Early front panels were painted with black "wrinkle" type paint, common to the period, but the paint required a baking cycle. And that is where Lucille Packard's kitchen oven came in, to serve as the paint-baking oven. Dave reminisced during the 50th-year interviews, that the first batch of food coming out of the oven after a run of baking paint had a distinctive taste of paint to it.

In addition to the renowned HP 200A oscillator, HP expanded its product line in the 1940's to include the HP 400A AC

voltmeter, designed by Dave Packard, himself. Most people don't attribute product design to Dave, but since he was running the fledgling company during the war, he did contribute to new products. The HP 300A audio wave analyzer, described later in the product section, was launched in 1941. There was also a beginning of HP dominance in the quartz-crystal-stabilized frequency standards, with the HP 100A of 1942. In those days, an unknown signal to be measured, was compared against the standard frequency, using an oscilloscope and a "Lissajous" pattern.

HP & Microwave. HP's first entry into the RF measurement sector was introduced in 1943. The Model A signal generator had a 500 to 1350 Mcps range. The parameter "cycles per second" (cps) was used before the Hertz designation, which came years later, at the instigation of the National Bureau of Standards and the IEEE. The Model A was a U.S. Navy model, designed elsewhere, using lighthouse vacuum tubes, which HP put into signal generator production. HP's fabrication skills were used early, to improve on the Navy design, with such techniques as machine lapping and honing surfaces mechanically. These careful mechanical processes improved electrical noise performance, and carried over to later years, when those HP product qualities were praised and desired. A commercial version of that wartime product, the HP 610A UHF signal generator, was introduced in 1948.

In the late 1940's, Varian Associates had been founded in the industrial park, by Stanford graduates, Russell and Sigurd Varian, who had invented the WWII klystron tube. They offered HP a small line of waveguide test equipment, and HP purchased it to provide a quick expansion to their microwave line. Varian reasoned that they didn't wish to detract from their mainline klystron power tube business, which was booming with military and aerospace business from the Korean War. The product line consisted of some waveguide slotted lines and other components such as directional couplers, and the like.

During the same period, the U.S. Naval Research Laboratory began to contract with HP to design more advanced klystron signal generators. Out of that research, came the HP 616A Signal Generator (1.8 – 4.2 GHz), circa 1947, followed by many other generators covering frequencies up to 21 GHz. No doubt another reason for HP's development work in the signal generator sector was Hewlett's hiring of Bruce Wholey and Art Fong from those WWII labs in Boston. Both had specific technical experience in those product technologies.

The company grew and prospered and needed to build more and more production space. Most of that era is well documented, although it should be noted, that Dave and Bill always showed prudence and caution before investing big capital on buildings. They had concern that the post-WWII era might bring recession, as had happened after many previous wars. When the Page Mill buildings known as 7B and 7C were designed, Dave insisted that they feature large free-space bays, with few support posts in the interior, since he reasoned that they could always be leased for a supermarket, if HP's business revenue crashed.

••••••••

The Sales Representatives

In a real sense, HP could never have been successful without the early association of a world-wide group of independent sales organizations known as Sales Representatives or "Reps." These sales professionals were highly specialized in the electronics technology, and were most useful to young and growing manufacturers, who needed sales outlets in the US and around the globe. They were established and going concerns, with close relations to the precise customers that HP needed to reach.

What the reps offered, was knowledge of the local markets and a fully-operating organization with offices, sales people, service facilities, and full support of accounting, etc. Their repair and calibration centers were also highly valued. They did this for a sales commission of 15%, less in certain areas where the higher concentration of customers made operating costs lower, going down to 12%.

These independent businessmen represented many different manufacturers or "principals." They took special care that their various product lines didn't compete with each other. In fact, they were mostly complementary, supplying compatible extensions of test and measurement product lines. For example in the early days, Neely Enterprises, who did business in the Pacific Coast states, handled both HP instruments and Tektronix scopes, with no conflict, since HP's scope line didn't emerge until about 1965. Neely also handled BLH (Baldwin-Lima-Hamilton) strain gages, Sanborn strip-chart recorders, Boonton Radio VHF test instruments, Varian Klystron tubes and instruments, and others. HP later bought out several of those complementary companies and their product lines.

The story goes that from a tiny ad in the IRE Proceedings magazine, H and P got the first mail inquiry from the chief engineer of Walt Disney Enterprises. Dave Packard boxed up an HP 200A and took a train to LA. He found out that Norm Neely of Neely Enterprises had been handling a line of radio tubes and components for some years. He walked into the Neely office in West LA, with the HP 200A box under his arm, and wondered if anyone there knew how to sell instruments? Needless to say, no salesperson could turn down that challenge, so someone took him out to Disney, and the rest is history.

In the 1950's, the Northeastern U.S. was represented by a single organization called Burlingame Associates, managed by Col. Burlingame. When the old Colonel died, there was some legacy difficulties with the Burlingame family estate, and his business staff regarding their management succession and ownership. HP chose not to wait for it to settle out. It set up new business relationships with many of the previous city managers from the old Burlingame organization. Thus, Tiny Yewell set up Yewell Associates for Boston and Northward. Robert Asen, Milt Lichtenstein, and Charlie Sargent got together around New York City, and formed RMC Associates. Ivan Robinson and Company covered the area around Philadelphia. Fred Horman took the Washington area, and Rube Ryerson covered upper-New York state.

Meantime, John Bivens and Dave Caldwell, headquartered in

High Point, NC, covered the Southeast, except for Art Lynch, who represented Florida. Earl Lipscomb, a feisty little Texan, ran his Texas company with spirited enthusiasm, while Sy Sterling catered to the highly industrial-type market in the Detroit area. Sy featured special instrumentation system engineering, well before it became stylish to provide complete measurement solutions.

Al Crossley covered the greater Chicago region, while Harris-Hanson had their headquarters in St. Louis. As mentioned before, Norm Neely Enterprises covered a vast territory for that time, all the way from New Mexico to Northern California. Denver had Pete Lahana, while the greater Northwest U.S. territories had a rep called Arva Company, owned by Ron Merritt.

International trade was handled in those early stages by foreign trade brokers who managed the much more complex business of international shipments. This involved financial letters of credit, government customs documentation, and much more. There was little attention to selling, just order taking through the mail and telegrams. Gradually, in the foreign countries that had large sales potential, international sales representatives were brought on board. Many of these companies were similar in organization to the U.S. sales rep companies, except for the more tenuous communications processes.

Unique individuals and companies. Each of the Independent Rep companies had their unique personalities. The Neely organization was highly organized, almost like a military operation. His field engineers all seemed to be stamped out from the same mold; crew cuts, clean cut, aggressive, etc. Their central organization, headquartered in North Hollywood, was located on land that was one of the original Spanish land grants, and the site of the peace treaty of the Mexican-American War, Campo de Cahuenga.

Neely built most of his district offices, around California, Arizona and New Mexico, in the Spanish mission style, with tile roofs, graceful outdoor corridors, etc. And almost all of them had a stylish bar room, usually called the Cahuenga Room, which might open for special occasions during the day, but would be opened at the end of every work day. Visitors were always pleased to take a period of relaxation in the bar. Neely's North Hollywood headquarters was just down Lankershim Blvd. from Universal Movie Studios, and we always accused Neely's personnel manager of recruiting all the rejects from the movie casting room at Universal. Neely's personnel were very photogenic and usually single. Such hiring policies could never be tolerated today's corporate environment.

The Bivins and Caldwell Southern region, on the other hand, was all Southern charm, but financially, it was run on the cheap. Visitors were treated graciously, yet the business mode was relaxed. When I was Microwave Division Marketing Manager, I recall losing a rather large big-deal contract with one of B&C's customers, and I felt that it was due to the relaxed way the FE pursued the customer. When I called John Bivins to complain, he merely said, "Don't worry, John, we'll get the next one," a typical laid-back attitude, I thought.

The hundreds of field engineers, across the country, were a diversity of personalities, from non-stop selling machines to good-old-boys. The style of their selling process was distinctly personal. For example, during one of the busiest aerospace periods, the AC Spark Plug Division of GM in Milwaukee landed a very large radar contract. Our Crossley field engineer, Fred Nearing, was so busy with all his customer's specifying and purchasing activity, that he simply couldn't make appointments fast enough.

On one my customer trips with him, we walked into the reception room, and he picked up the plant telephone, and had himself paged. That was the signal to customers all over the plant, that he was in the lobby, and available for consultation. It seemed insensitive to me, but customers that day told me how valuable Fred had been to their project, so obviously his sales method for that ultra-busy time period, was working just fine.

On a sales call to downtown Manhattan, in the early 1960's, Stu Yellen and I called on Western Union, which was housed in a skyscraper on a narrow street, just a few blocks from the New York Stock Exchange. We drove up, and Stu triple-parked, while we went inside and up to the 24th floor. I was flabbergasted, since we stayed for almost two hours, selling, and although I worried, and kept asking about a parking ticket, he never mentioned the car. We had no ticket when we got to the street. You've just got to know the territory.

On another sales call with Stu, he needed to drop by the Consumers Union Test Lab (publisher of the popular *Consumer Reports*) north of New York City, to pick up a loaner oscilloscope. Stu had offered the loaner to a test engineer, to try to convince him that HP's scope had better features, although Tektronix dominated the scope market across the board. Sure enough, the first thing the engineer told Stu, was that he had decided to buy Tek. I'll never forget Stu's answer, "But, if you buy the Tek scope, I won't get any commission." And, with that, the customer changed his mind. It was that personal service that Stu had given that customer over a long period of time, which sold the product. It was another lesson for me, a fledgling, factory marketing neophyte on the road, that I never forgot. It was that personal touch and the service, that our sales representatives brought to the customer.

A lot of those personal relationships that our Field Sales Engineers developed with their customers were never revealed. Yet we knew that they worked hard on them, and occasionally the more-interesting stories would come out during some of our customer visits to the field.

When I was Microwave Marketing Manager, I accompanied our local Rep, Earl Davis, for a visit at the U.S. Air Force Procurement Center, Kelly AFB, San Antonio, Texas. These huge military commodity centers were responsible for central procurement management for the hundreds of thousands of commodities items. The military services used the central management process to take advantage of quantity discounts, and to manage procurement of military-specification equipment. Our customer that day was a so-called Item Manager, who in this case was responsible for annual procurements of test equipment and certain nuclear weapons

components. Although I was responsible only for microwave instrumentation at HP, Earl was checking up on a particularly- large contract for oscilloscopes.

Frank, the item manager, told Earl that it looked like the responsible procurement engineers were not going to award the scope contract to HP. Earl, who had been working closely with the USAF Test Engineers, noted that they had told him HP had been on the inside track, technically, and met all the performance requirements. But, Frank said it was going to go to a Tektronix competitor, not Tek, but a low-priced supplier, well known to all of us as a truly inferior contractor.

It was interesting to watch Earl, who I could tell, was not pleased, but protested hardly at all. But I stepped in, and was a bit incensed, showing my reaction as a good U.S. citizen, who didn't understand why they weren't buying the better HP product. Frank reached over and pulled out the top writing surface of his desk, which had a spread-sheet taped to the surface. He pointed out to me that of the \$65 million of test equipment that he bought every year, that during the past year, he had purchased over 70% of his budget from HP. He felt that he had surely done his part in buying as much high-performance equipment as he could justify, and a lot more. I had to agree.

When we left and were driving back to the office, Earl told me he was pleased that I didn't carry the argument any further, as an HP employee. We obviously were already getting far more than our share, and if we had made any complaint on the scope deal, it might have upset the relationship for all his other deals. For most of the high precision test & measurement equipment the USAF bought, they did follow a legal (and very tedious) specification generation procedure, which outlined the precision requirements they had in their test departments and in the field maintenance shops.

I gained an entirely new respect for Earl and many of the other front line sales people, having seen in so many cases, how they worked with their customers to help achieve a win-win for both of us, customer/user and HP. And, I gained a similar respect for the military civilians who were tasked with the responsibility of procuring massive amounts of equipment, buying the best they could. Yet they were bound to use formal and tedious bidding processes, intended to yield the lowest price for the taxpayers. In spite of that, they still usually ended up with a predominance of excellent and high performance gear for our forces.

•••••

The Annual IRE (later IEEE) Show in New York City

In the 1950's, electronic products had not yet proliferated into so many different market and technology specialties. There were two main trade shows for the industry, the IRE (Institute for Radio Engineers) show, held every spring in New York City, and the WESCON show held on the West Coast, alternating between Los Angeles and San Francisco. For some period, the IRE show was held in the Grand Central Pavilion, which was next to the fabled Grand Central Station, over on Park Avenue. Exhibits were quite informal, often consisting

of draped tables and simple backdrop signs to merchandise the products.

In 1962, the IRE combined itself with the American Institute of Electrical Engineers (IEE) to become the IEEE, the Institute for Electrical and Electronic Engineers. Their annual convention moved to the newly-constructed New York Coliseum, a very large convention center at the corner of Broadway and Central Park South at the southwest corner of Central Park. This annual gathering of the electronic clan brought out everyone who was anyone in electronics. It was a week full of technical papers and a huge trade show.

The IEEE Show used up 4 floors of the convention center, necessary to fit in all the exhibit booths, and multiple lanes of technical sessions. As the visitor came through the front doors of the Coliseum, and registered, there were 4 high-speed escalators that moved the crowd to the third floor. There, right at the top of the escalators, because of the size of the booth, and our years-long priority positioning, was the HP booth, 100 feet long, with exhibits on each side of the aisle. HP was the first company to request that the floor carpet be run across the aisle, which thereby created a single "booth." It was always a totally impressive and awesome display.

Show setup processes were well established over years of operation. The HP show managers, Don Teer and Frank Court, planned for a year in advance. They worked with all divisions and got the displays designed, with the appropriate signage, electric power, and all the equipment. They contracted with the moving van company to use a padded moving van for the move across country. By driving continuously, driver Tiny and his helper could make the trip in less than 4 days, stopping for more equipment pickup at HP, Loveland, Colorado. But, naturally, with the Spring weather in the Rockies and Midwest, it could occasionally cause some nasty surprises on the travel conditions, and some years, there were some real cliff hangers in getting everything to NYC.

At the Coliseum, trucks would be lined up around the block, all jockeying to be unloaded. By previous negotiation with the dockmaster, Tiny would drive his truck cab by itself onto an enormous elevator and take it to the third floor. Then using another cab, they would back his long moving van trailer, by itself, unto the elevator, and take it to the third floor. There, Tiny would hook up and drive the HP equipment over the third floor to our booth location. Afterwards, they would reverse the process and bring the empty truck back downstairs. None of us ever had the guts to ask Tiny how creative it was to negotiate that preference with the dockmaster (or how large the bribe was).

The Bombay Bicycle Club. Dozens of HP people and Reps were flying in from all over the country to attend the show. Our headquarters hotel was the Essex House (now a Marriott), an older hotel on the very southwest corner of Central Park overlooking the Park. The higher-level management people, and almost all the Reps personnel, stayed at the Essex House, while the plebian engineers, like ourselves, were assigned to the Barbizon Plaza Hotel, just down the block.

As people began arriving, all during Saturday, as the flights came in, most people would check in and begin to congregate in the Bombay Bicycle Club, a bar at the front of the Essex House, overlooking Central Park. Senior HP people would begin running an HP tab at the bar. Two and three tables would fill up with old friends, from various divisions and field offices.

People would come and go as the bar tab was rising ominously. By the time many people had met friends and gone out to dinner, and came back and re-met other friends, the bill could be hundreds, maybe a thousand+, dollars. Of course, this was merely the signal for the senior HP sales people to arrange to all leave at the same time, usually leaving one or two junior travelers to pick up that enormous check. It took a year or two to learn.

Sunday was set-up day. Don Teer or Frank Court would have worked half the night getting the booth itself set up with the lighting and rugs and signs and power. Then division personnel came in, to set up the equipment and cable it together, and to find out for the first time in NYC, whether the demos were going to turn on properly. To those of you young engineers who have never known anything but semi-conductors, let me assure you that those days of vacuum tubes could be very trying times.

It was a standing practice to have the service and repair personnel available, over at the RMC Associates office on East 72nd Street, for special trouble-shooting duty during the duration of the show. Engineers with service problems would hail a cab to do some troubleshooting. Since most of the troubled instruments were brand new, most had no manual written yet, and so the best effort often involved long phone calls to the factory, or to some project engineer's home in California on Sunday. But, surprisingly, most of the displays were purring away merrily, on the big opening event, on Monday morning.

The Annual Sales Kickoff Event. The IEEE Show became our big annual new product faire. We used that time in the Spring to focus the factory's year-long R&D efforts, to be finished in time for that event. Therefore, since HP domestic sales were handled with 13 private Sales Representative companies, it was logical to make the IEEE event into the big annual sales meeting. HP would retain the giant Essex House Grand Ballroom and all the Reps brought along as many of their sales people as they could afford.

Probably the largest sales meeting was about 1966, when almost 400 HP divisions and field sales office people gathered for the meeting. Dave Packard would keynote the dinner with motivational speeches by Sales V.P. Noel Eldred and HP Labs V.P. Barney Oliver, and many others. After that year's huge expenditure, Packard observed that there probably were more cost-effective ways to get the word out, rather than doing it with a whole HP army, spending like sailors in always-expensive New York City.

It may have been that meeting, about 1965, when the Microwave Division wanted to recognize Lyle Jevons, for his peripatetic field travel, introducing the HP 8551A spectrum analyzer (see the Product Section). Its huge sales success was

due in a large part to Lyle's ability to find new applications, and tens of millions of revenue resulted. John Young and I approached Dave Packard, who agreed to make the presentation, but come the end of dinner, Jevons was nowhere in the audience. I found that Lyle was in his room asleep, wanting no part of such notoriety, so I prevailed on John Young to get upstairs to rouse Lyle, get him dressed and to have Packard pay him his due.

Dave Packard had a real common touch, which recognized the plague of bureaucracy. During one of the factory campaigns to cut operating costs, one of the finance managers in headquarters (Frank Cavier) set up a new policy of cutting back cash advances made for travel. Sales and marketing people protested for months, in that, especially for big cities, where expenses were truly high, that there should be some flexibility to the policy. The word got back to Packard.

In conjunction with one IEEE trade show, and after HP corporation stock went public in 1957, HP would often set up a meeting with New York's Investment Analysts. Finance V.P. Frank Cavier would typically accompany Packard and others to New York to assist in the financial presentations. One night, Packard hosted a medium-sized dinner meeting with the Rep managers, and invited Frank along. When the bill, for several thousands of dollars, was presented, Packard made sure that Frank got to pay it. As usual, Frank hadn't brought nearly enough money to cover such an expense, and we never found out how he paid the tab. But soon after his return, our marketing travel advances were much more flexible.

Being independent companies, the 13 U.S. Sales Representatives were as different as any group of hard-driving individuals. Their personalities were wonderfully inventive and personable. And, their personal relationships with Packard and Hewlett and Eldred went back to the earliest years of the company. We understood that most of their business contracts were done with a handshake.

Tiny Yewell was one of the most boisterous of the Rep. owners. He had an initiation rite for his new field sales engineers, that they would spring on those new people every year, at the IEEE show. All his managers and senior personnel would gather in Tiny's hotel suite on an upper floor of the Essex House. Previous to the trip, the fledgling engineer would have been told that he would get a call at a particular time, to come up to Tiny's suite, for a drink and informal talk.

One could only imagine the worry that a new engineer might have, with such a call. With the whole senior field group sitting around the room, and the new man knocking at the door, Tiny would tell him to come in, the door was unlocked. Imagine his surprise, and the delight of the audience, when he opened the door to find a naked woman greeting him, face on. Once HP bought out the Rep Organizations such antics were quickly eliminated, since they had no place in a professional company, maybe not even in those independent organizations.

•••••

The Sales Representatives' Road Shows

Understanding the personal relationships that developed between field sales engineers, working for the independent representatives and customers, will help position the social aspects of the field road show. I first came into knowledge of the Rep's road shows, way back in 1952, as a student senior at Notre Dame, about 90 miles east of Chicago. The Crossley organization, out of Chicago, would load a roomful of equipment demonstrations into a caravan of station wagons, and drive all over their Midwest territory, making one-day stands in hotels and school conference facilities.

The strategy was to produce a presentation of new products and applications, for a once-a-year swing through the Rep's territory. This, in turn, would bring together all the Rep's field engineers and a generous visitation of factory marketing engineers, plus some appropriate R&D engineers, who were made available to promote their proud new product offerings.

The caravan event itself, was often quite a long week or two, with considerable drinking and card playing at night. Daytime decorum was absolute, and business practices were followed religiously. There were strict regulations, enforced usually by the second in command, from the Rep office. If you wished to carouse the night after a show, and get to bed drunk at 3 am, you needed to be sure you were up and ready for travel by about 8 am. Whether or not you had breakfast was not important, you just needed to be sure you met the departure time of the caravan.

I inferred that many of such people either skipped or drank their breakfasts (you don't think I would admit being in such company?), and didn't see any hard food until later in the morning. Remember that these operations happened during the independent Rep days, where a large corporation like HP was not responsible for personal activities. It could never happen, once all the Rep organizations had been acquired by HP, because of the obvious deep pocket responsibilities and social concerns of a major corporation.

Bob Brunner demos. Bob Brunner started as a lab engineer in HP, and was responsible for the design of the highly-innovative HP 202A ultra-low frequency function generator. It cleverly depended on generating a square wave that was as low as 0.08 Hz. He then integrated the square wave, to form a triangular wave, and then diode-shaped that into a sine wave, all waveforms of which, were individually-selectable for output. Bob then moved into Neely's sales organization, where he started as a junior engineer. These were the years before Neely was bought out by HP.

One of the jobs assigned to Neely's junior engineers was to organize their annual Road Show. In the early years, this amounted to maybe 10 or 20 station wagons laden with instruments and sales people, making their way across the desert. In later years, it was a large cargo van, accompanied by the cars full of people. Neely Road Shows were legendary events, and while I won't say there was much after-hours drinking, I can remember that there were reports that many participants drank their breakfasts of silver fizzes and Bloody Mary's. Not me. You can believe that or not.

The "breathing zero" demo. Bob was probably the most creative designer of the Roadshow, ever. His specialty was in finding particularly interesting demonstrations of our equipment. For the engineers reading this, you will appreciate several examples. The first was the so-called 100 breathing "O's." In the late 1950's, HP electronic counters had just been designed to be able to print out their numeric display count. In today's age of a multitude of data buses, it sounds crazy, but the first electronic counters could not communicate their number displays with the outside world.

That newest counter technology arranged for each digit, represented by a "decade" counter module, to create a staircase waveform, stepping up one 10-volt step, 0 to 100v, with each increase in its number count. So, when the numbers were continually increasing, the output was a staircase voltage, which told the printer which number to print.

Bob arranged one decade staircase voltage to drive the horizontal input of an oscilloscope, and the adjacent decade, which was going 10 times slower, to drive the vertical input. These two staircases thus created a 10 x 10 matrix of 100 dots on the scope. Bob then added in a small Lissajous circle at each dot intersection, and used an audio oscillator to slowly open and close the circle. This made a display of 100 "breathing" zeros, in and out. Such a dynamic display, of course, caught the eye, from all the way across the room. Which then allowed us to talk to customers about HP's magnificent "printing counter."

In the interest of full disclosure, Bob's demo was not really called the 100 breathing O's, even though that is what it looked like. The O's term that was really used, was one that describes a human body part, which I will not write down, but it starts with an A and has 7 letters.

The anvil demo. During those years, in addition to representing HP, Neely also represented Varian Associates. One of Varian's high-tech products was a tiny Klystron tube, which was used as a local oscillator tube in ground-to-air missiles. As such, it had to perform with great frequency stability, even in the severe mechanical environments of shock and vibration, especially at launch time. Bob's display consisted of a regular shop anvil, arranged with the Varian Klystron on the end of a flexible rubber waveguide, which could be smacked against the anvil. So, in the large display hall, every so often, one would hear CLANG, CLANG, CLANG. It absolutely would rivet your attention when the CLANG started.

The genius of Bob's demo was that HP had a new frequency stability measurement instrument, called a transfer oscillator. He arranged the demo to monitor and display the frequency stability of the Klystron (its most important parameter), through the flexible waveguide, during the time it was clanging against the anvil. This showed the Varian Klystron's remarkable mechanical performance, and in turn, sold the technology of our new HP frequency-measuring instrument.

RF/Microwave Symposium. A later version of the earlier Rep Road Shows was a specialized customer event, conceived by Santa Rosa's, Dean Abramson, and others, in the late 1970's. It was called the RF and Microwave Symposium, and

ran in the period from 1978 to 1990. It was so successful in its results, that it became a very long-running event for that normally-mundane product sector. Dean's concept was to take a medium-sized conference roomful of equipment demos and a day-full of technical papers to each major U.S. city once every two years. Typically, the papers would be presented by lab engineers with new products or new technical applications. Since up to 6 different product divisions were involved, there were typically 15 to 20 measurement demo tables in the exhibit room.

It was a wonderful opportunity for our normally-sequestered R&D lab people to meet actual customers, and to interact with our field engineers (FEs). It permitted management to reward those engineers for their project work, with some travel and some earned prestige in the eyes of their customer's engineers. It elevated the technical knowledge of the FEs, and raised their standing in the eyes of their customers, because they could personally escort their key customers around the room to see 15 or more tables full of the newest applications and products.

Organizing these gatherings of hundreds of customers and dozens of field and factory engineers was anything but trivial. But, once we got through most of the regions involved, the follow-on events usually went smoothly, but not guaranteed. Electric power was often critical. While we would ask the field manager, who was responsible, to assure that we had an honest 120 amp of power, it was never certain. For example, at one stop, a local electrician was brought in by the hotel to modify their power circuits. Unfortunately, his solution was to bring the entire 120 amps through a single power cable from the basement, for a total run of maybe 200 feet. Needless to say, by the time all the tables were hooked up, the resulting voltage on the floor was less than 100 volts, which caused many instruments to randomly fail to run properly. We could see the problem happen in front of our eyes, as more and more tables were turned on, and more power drawn.

Another incident I recall, was the Molly Pitcher Inn, in Redbank, NJ, adjacent to Bell Telephone, Holmdel, and the U.S. Army's Fort Monmouth. This old, colonial hotel was about 150 years old, with Revolutionary War connotations. I think the legend was that Molly Pitcher took up arms when her husband was killed by the British. We again had asked for 120 amp supplies, and were setting up late on a Sunday night. The problem was that their electrician probably had a second job as a blacksmith, because the circuit breakers began to pop as we turned on table after table.

The hotel manager at midnight was of no help, and the show was scheduled for 8:00 am. So, several of us found the main power circuit boxes in the basement, and began to rewire, using lighting circuits and other services like the laundry room, etc. We got the power we needed, but I am sure that we illegally violated at least several municipal electricity codes in the process. Next day, when the management found out, there was much unhappiness, until they got a real electrician to bless what we had done. But the show always went on.

There seemed to be a lot of problems with the heat and cold. Our equipment pushed out so much heat, air conditioning was always a matter of concern. And we didn't want to chase

these good customers out because of the heat in the rooms. In the Midwest, many hotels' conference facilities were inexplicably constructed with EITHER heating or air conditioning, but not both. So if the weather was just turning in the springtime, you had a good chance of only having the heat mode going, when you needed quite a lot of air conditioning. One day I even ended up frantically calling the hotel's corporate headquarters of ITT, which owned the hotel, just to try to get the attention of the hotel manager, who didn't seem to care much about the stifling heat, since he said that give it a week, and he would need the heat again, when the weather changed back cold. Now there was real customer insensitivity.

We tried to keep the symposia technically meaningful, but informal. At one leadoff technical session, I decided to tell a technical joke to the audience, before I introduced the first speaker. It seems there was a Polish airliner, coming in to land at Warsaw, Poland. As they approached the city, the pilot came on the speaker, and noted that downtown Warsaw was visible on the right side of the cabin. So people got up to move over and look at the view, whereupon the airliner began to oscillate back and forth, turned over, and crashed.

The Polish version of our U.S. Civil Aeronautics Board, went out to investigate the crash, and after some months of study and diagnosis, determined that the cause of the crash was due to "... instability, caused by too many Poles in the right half of the plane." For the benefit of the non-technical reader, all engineers learn, in their theory of feedback loops, to construct a graphical plot of the mathematical stability data for the electronic amplifier. The plot contains what are called "poles" and "zeros." If there are more POLES than zeros (in the right half of the graph paper), the control loop is unstable. In this case, most of the audience groaned, and didn't clap, but as I introduced the speaker and walked to the rear, a Slavic-accent gentleman spoke to me as I went by, "That joke was in very poor taste, and Mr. Hewlett is going to hear about it."

Well, luckily, my boss, Division Manager Rod Carlson, happened to be in the audience that morning. I later mentioned the complaint to him, and we agreed that since the joke was quite a subtle technical thing, that it was likely that the man didn't have any feedback theory in his background. We assumed that he just mistook it as another dumb Polish culture joke. And as it turned out, Hewlett never did hear about it, apparently, or at least he never mentioned it to me.

Creative thinking on field demo transports. Road shows in the U.S. or Canada and other large countries were pretty common. Station wagons or trucks could be used for transport. But what to do about small countries? My memory fades a little on this, but someone in the International Sales Division, under Bill Doolittle, came up with the idea of a flying demo airplane. HP purchased or leased a DC-6 freighter, and outfitted it with demo tables, rugged hold-down fixtures for demo instruments, auxiliary power & distribution and arrangements to accept a continuing stream of customers. The demo airplane flew into South America and other regions of the world of small nations, to bring our HP technology to places that would never have seen such a wide ranging display of different products. By keeping the demo equipment

aboard the plane, the usual customs problems were avoided at each location. It was a considerable success, and I recall that it ran for one or two years, after which HP turned back the airplane.

Another interesting demo vehicle was to set up some staterooms on a tramp steamer vessel. It seems that there are routine shipping routes that ply up and down the two coasts of South America, picking up and delivering freight. HP arranged to lease several staterooms for instrument demos, and bring on board local field engineers and customers when the ship was in port. Someone had observed that a high percentage of our HP technical customers in South America were in the larger cities which were mostly along the coasts. If the ship was in port for a day or two, that was all that was needed. I seem to recall that that method lasted for only one tour. Perhaps a second year.

•••••

The Annual Management Meeting at the Mark Thomas Inn, Monterey, CA

As the Corporation entered the 1960's, it moved from a small group of managers, to 4 full-fledged divisions, plus a number of newly-acquired companies like Sanborn, Moseley, Harrison Labs, Boonton Radio, and a growing group of corporate staffs. To coordinate this diverse group of people, an annual management review was held at the Mark Thomas Inn in Monterey, California. Previously, smaller groups had met in Sonoma, CA, or other out-of-the-way places, to retreat a bit from the busy office clatter.

Format for the Monterey meeting was to drive down on a late Wednesday afternoon, and meet on the patio for an informal reception, to get to know some of the new people who had joined the assembly, since the previous year. Field Sales Managers from the sales representative companies were invited, and they brought a boisterous flavor to the gathering. Dinner was followed by a viewing of a gallery of candid photographs, featuring disrespectful and sometimes politically-incorrect captions, that were hung on the walls all around the dining room.

The photographs and captions were the work of several individuals, Corporate Patent Attorney, John Chognard and Public Relations Manager, Dave Kirby, who were privy to know the foibles and fallacies of most of the upper-management photo subjects. The photos were blown up to 2 x 3 foot size, and had large cartoon-like captions attached, putting statements in the star's mouth. A typical photograph might show R&D V.P. Barney Oliver, sitting in a product review meeting, but caught by the photographer's flash with his eyes half-closed. Then the caption might show him thinking, "A breakthrough worthy of Einstein," or some other irreverent words. Or, it might show Noel Porter, V.P. of Manufacturing, in a similar group review setting saying, "When does the bar open?"

There were typically about 40 of these photos posted around the room, and as we came in from the well-lubricated dinner, it took some time to get around the room, as there was wild laughter as the group looked over that year's creations.

The HP Archive actually has most of those ancient posters on file, and I examined them back in the 90's before the present corporate management took over. For this work, I requested permission to reproduce 2 or 3 of the funniest (but those fit for a family publication), but the request was denied without explanation.

We always heard from Dave or Bill to set the theme for that year's conference, whether it was to be product-strategy-focused or a look at production efficiency, or international sales. That could also be the time for Barney Oliver to dazzle us with a broad-based overview of what was happening in HP Labs. Even at that time, the forward technology coming out of the labs represented the direction that HP would be taking for some time. And Barney had away of bringing the business impact to a level we could appreciate.

Typically the organizers would also set up a skit, consisting of top managers, assigned to read a prepared script. One example was to have Dave and Bill set up in side-by-side chairs, to resemble the seats in an airline. This was at a time when both men were traveling so much, that there were internal complaints that they were almost never at HP.

In the forced script, the two men introduced themselves, as if they didn't know each other. Dave said that he was finally returning home to Palo Alto, after a month on the road, in the states & overseas, and that he was looking forward to returning to his small electronics company. Bill said that he too, was exhausted from a long tedious business excursion, and that he too owned a partnership with another young Stanford graduate. The script was much better written, but you get the idea.

Which brings up a funny riddle of the time. What's the difference between God and Dave Packard? Answer: God is everywhere, and Packard is everywhere except at HP.

The next day would be a complete agenda of a variety of issues. We would always get a financial report from Finance V.P., Frank Cavier, in the earlier days, and later, from Ed Van Bronkhorst. These could get a bit dull, but were important since HP took such pride in growing only as fast as the internally-generated profit could be put into use. With a variety of financial cycles going on in the external world, the reports from the finance department were quite useful.

Vice-President Noel Eldred made the report for Marketing, and the outlook for the year and beyond. Noel was a marketing professional's professional. He often took the occasion to do a little preaching to the assembly. In those 1960's, HP marketing was just beginning to get its sophistication going. Noel was a self-made, marketing professional, and just had an intuitive sense about serving customers' needs. He preached that HP needed to serve needs, and not just part customers from their money.

We could always expect a report from the International Operations V.P., Bill Doolittle. Most of us looked forward to this report, because each year Bill seemed to outdo himself, with how much information he could crowd onto each single overhead slide. (Austin Marx, the Corporate economist would

provide the slide numbers.) International operations were growing unbelievably fast. From a sales value of about 5 million dollars out of 105 million (5%) in 1960, the international sales expanded to almost 20% of world revenues in 1970. These were enormously busy years for Doolittle and his staff, because sales responsibility of so many of the countries were being turned over to new HP-owned companies in those countries.

We always heard a comprehensive economic report from Austin Marx who was responsible for our corporate economic forecasting. It was Austin's job to pull together comprehensive data on economic forecasts, and sources of technology funding, as they applied to HP, aerospace, government R&D budgets, etc. He also was famous, perhaps notorious, for shoehorning a vast amount of data on each slide, using little marks and annotations appended to the normal bar charts, footnotes, side-notes, etc.

•••••

Hewlett-Packard and Me

After my Sandia atom bomb test work, and the USAF tour, Jane and I headed for Stanford and Palo Alto, where we would spend the rest of our lives.

The HP job interview. We had always intended to return to Albuquerque, NM, after graduation from Stanford. I am sure my previous job at Sandia would have been open. But I decided to visit HP in October, 1957, to see what might be available for engineering work for me. Since HP had no personnel department in those years, and I had not made an appointment, Anne Laudel, the front office receptionist, went back to see if someone in engineering had time to talk with me. Imagine my surprise, when she ushered me into Barney Oliver's office. I would have been far more intimidated, if I had known at that time, that Barney was a 180 IQ genius, and was well known for demolishing most of his technical interviewees of the time.

Actually, things went very well to start. The Russian Sputnik had just flown, to the consternation of the U.S. Defense Dept. As luck would have it, HP had participated in a crucial measurement of the basketball-sized satellite. Dr. Alan Petersen of Stanford Research Institute, up on the hill behind Stanford, had used an HP frequency counter and a Collins Radio HF receiver to determine the slant range (altitude) up to the satellite, as it made multiple passes overhead.

By analyzing the frequency Doppler effect as Sputnik came towards and then receded from the Collins receiver, they could calculate the altitude. And, in some way, this allowed them to determine the thrust of the rocket technology that the Russians must have had available to put it in that orbit. As the cold war was raging, and the U.S. was way behind Russia in rocketry, needless to say, the U.S. Defense Dept was urgently trying to find out any information that SRI, and in turn HP, was able to measure.

Some of my previous telemetry instrumentation work at Sandia came in handy for me right then. We had to deal with the same Doppler effect on telemetry signals of air frame tests

for atomic bomb models. These were dropped from airplanes, to test their free fall parameters. That experience allowed me to keep up with Barney, in his discussions of the Doppler frequency effect of the satellite. But only for a short time. Then he started his technical questioning, and very soon, he said, "I think it might be good for you to talk with our marketing people." So, he took me out and introduced me to Cort Van Rensselaer, the sales manager. We made an appointment for a later interview, and my subsequent hiring by HP.

I have been very happy, working almost my entire career in marketing at HP. I found it fascinating and interesting and challenging, although, in later years, Barney and I would laugh about my introduction to HP and to him. At the time of the HP interview, I had also intellectually made the decision to move out of weapons work. I finally had faced the fact that I didn't want to spend a career helping to make more and better atomic bombs. In my 2.5 years with Sandia, I guess I witnessed probably 15-18 hydrogen and fission bomb blasts, and they make one awestruck each time. It is like the sun rising on command.

Although the atomic work was exciting and dramatic, I have never once regretted that decision to leave it. In the decades since, I know I made the right decision. Why would any nation need 60,000 atomic bombs? That quantity is what our country's leaders built, through both Democrat and Republican administrations. It was the military-industrial complex, that Dwight Eisenhower warned about. And it was the Cold War, which gave such organizational madness some political cover. And, as it turned out, every single one of the 14 national nuclear materials or bomb-making lab locations around our nation is highly contaminated. It is going to cost our nation a trillion dollars to clean them up, over the next 30 years.

At HP, as I worked my way up the marketing ladder, I found tremendous challenge and excitement in understanding and solving customer needs. HP was at the forefront of all the technologies in instrumentation, and those innovative products were needed by customers who were all over the business landscape of science and engineering. Satellites, integrated circuits, communications, medical advances, industrial processes of all types, automation, computer assisted measurements, and finally breakthroughs like the HP 35 engineering hand calculator in 1972.

In 1958, my first position was sales engineering to support field operations on the East Coast. John Young and I were responsible for the two independent Sales Representatives in New York and Eastern Pennsylvania. RMC Associates covered New York City and New Jersey, while Ivan Robinson was responsible for Philadelphia and to the middle of the state. John and I would spend alternately 2 weeks on the road every two months. The first week, we would visit customers in the Philadelphia area, and the next week take the train to NYC to work with those field engineers.

The customers ranged from the telephone communication geniuses at Bell Labs, in Murray Hill, Holmdel and Whippany, NJ, to testing the F-14 Navy fighter at Grumman on Long Island. We worked with aerospace folks and the

Navy's Aviation Supply Office commodity purchasing center just north of Philadelphia.

Later, when the Sales Reps were all purchased, and the Microwave Division (MWD) was formed, I was promoted to Sales Manager under John Young, and a year later, when he moved up to take over the division, I got the Marketing Manager job. I think we had about 15 people in marketing. I still remember the year, 1962. There was a recession on. I think the MWD revenues were \$20.5 million dollars. We stayed about constant in sales for three years, held up with the serious economic downturn.

Minck's self-promotion. To show how simple the organization was, when I took over from John Young, as sales manager of the Microwave Division in 1964, I felt I was truly lacking in professional marketing knowledge. So I signed myself up for a 3-week marketing course, offered by the American Management Association, in New York City, I think. It was an eye-opener.

The most important thing I learned was that the job description of what HP called a division sales manager, was actually called a Marketing Manager by the industry. So, when I returned home, one of the first things I did, was to have my business card reprinted, with the title, Microwave Marketing Manager. It took the other 3 divisional "Sales Managers" about a month to change their titles. There was, essentially, only the beginnings of a Personnel Department at that time, but, interestingly, no management approval was needed for such an action. It was just that informal. I don't even remember if I told John Young what I had done. I think he would have agreed anyway, since his mastery of marketing theory and practice was outstanding.

At the Christmas party in 1964, I made a bet with Nick Kuhn, who was Section Manager of one of the R&D groups. I said that if we beat our 1965 quota of \$25 million next year, I would jump in that unheated pool. I obviously thought that even \$25 million was aggressive. At the time we were sitting in the bar of the Los Altos Country Club, looking out over a very cold pool.



Sure enough, with the new HP 8551 Spectrum Analyzer, our sales boomed, and we came in for FY'65 at \$27.5 million. I went to a costume shop and rented a 1920's type men's swimming suit, with horizontal stripes, and donned a pair of gloves. With the whole division at the Christmas party, I dove in and swam one length, with Division Manager John Young

at the other end, handing me a hot toddy drink.

Our MWD tripled its business in just 5 years, up to \$72 million, and my group expanded to almost 80 people. Management was getting to be a drag for me. I used to explain that it was not like 5 years of experience, but instead, 1 year of experience 5 times over. In 1969, I was ready for a change. I asked John if he would keep his eyes open for some kind of technical job I could take for a few years. In just two days, he called me in and told me he wanted me to move to a tiny department at HP Associates, one of our HP affiliates which was starting to build light emitting diodes. It sounded exciting to me, so I stepped off the marketing treadmill and into what turned out to be jumping from the frying pan and into the fire.

I spent 2.5 years building the LED group and product line, and I was very proud of our results. The whole story is in the product chapter below. I then found that having built that group from 6 people to about 105, I was still on a mid-management treadmill, so I moved to a marketing job on a new product line of computer-operated systems. I worked there for 2 years, and in 1974, moved back to the Stanford Park Division to work in marketing communications, and out of big-time management.

Uses of the RF/Microwave Spectrum. As a naive son of a retired farmer, I was always fascinated by production lines in middle America. I visited the automobile lines of Ford in Dearborn, MI, Studebaker in South Bend, IN and the TV lines of Motorola in Chicago during my college days. For me, that vast production was obvious for consumers.

But it came as quite a shock for me to see some remarkably high production for high tech instruments once at HP. While at Stanford, on a business school field trip to HP, we saw racks upon racks of HP 608s burning in. After being hired, I was astounded by the hundreds and hundreds of signal generators, power meters and spectrum analyzers shipping out every month. Truckloads of equipment headed out all over the world. I used to think that every design or production bench in the world must be full.

As I learned about customer applications around the world, I began to realize just how wide spread the applications were. Further, in those days the American universities were graduating about 15,000 new engineers every year. And it was the golden years of technology, so applications were spreading in every direction. Further, most of those new engineers were coming to work for customer facilities and each one going into R&D needed a bench-full of test equipment.

It was around 1977 that Editor Joanne Englehardt of the Park Press newsletter urged me to write some application articles for our SPD employees. She wanted to describe the interesting and important uses that our products found in the technology world. She wished to not just raise some pride in our work but also to inform employees of the critical importance that so many of our products have in citizen safety and in producing consumer and technology products across the world.

The result was an 12-part series with these titles:

How our SPD Products are Used

1. The Customer Viewpoint
2. The Avionics Business
3. More Avionics and Navigation
4. Radars for Air Traffic Control
5. Microwave Communications
6. Mobile Communications
7. Military Communications
8. Military Radar
9. Electronic Warfare
10. Other Government and Military Systems
11. Commercial and Industrial Uses
12. Regulatory, Metrology & Miscellaneous

I also wrote a more technical and comprehensive look at all our RF/microwave applications in a lecture intended for neophyte field engineers. As mentioned earlier, all global new hires came to the HP Training Dept over at Page Mill and Foothill, for an extensive measurements school. I assembled about 50 color slides of all our interesting applications.

It was always an interesting exercise to find pictures for the lecture slide-set. Every picture of the HP product was pretty dull; keyboard, display, knobs and meters. But the equipment that our products actually tested was also very dull, for example, a ground-based radar receiver, might just be a rack full of blank panels, and a few pilot lights. So I usually fell back on finding a picture of the dramatic outside antennas of radars or those large communication satellites ground antennas.

I used a less technical version of the "Uses" lecture for the new employee orientation sessions at the division, so they would understand what sort of technological contributions our company was making.

Everything you wanted to know. . . In 1972, Dr. Rueben captured the attention of America with his popular book, *"Everything you always wanted to know about sex * * but were afraid to ask."* Soon the publishing landscape was awash with similar titles about "everything you wanted to know." Engineering manager Paul Ely published an informative, *"Everything you wanted to know about Management by Objective."*

How could I be far behind? Over the years our factory application engineers who supported the HP field engineers were regularly asked many questions that weren't covered by the product data sheets or a library full of application notes. Those notes generally covered specific measurement procedures. It seemed that with every newly-hired FE, we got the same question as they learned the sort of black magic world of radio and microwave frequencies.

So I published my generic view of little known facts about the subject, *"Everything You Wanted to Know about Microwave Things, but not so Much that You'd have to get too Familiar with James Clerk Maxwell."* Maxwell, of course, discovered the basic equations that governed the propagation of electromagnetic waves.

It was a basic tutorial about power, attenuation and voltage ratings of microwave products, which were characteristics not generally covered on product data sheets. I included information on how our products would perform just outside the normal specified frequency or power limits, since it seemed that some customer was always asking what would happen if he exceeded the limits a bit. I also gave a large bibliography of industry books that dealt with many esoteric technologies such as encrypted communications, electronic warfare and counter-countermeasures, and the industrial societies that were organized for those engineers that engaged in those classified occupations.



Stanford Park Division Profile

I have chosen to describe HP's 1960-era organizational philosophy by spotlighting one of the first four charter divisions, formed in 1962. Those divisions were, Microwave, Frequency & Time, Oscilloscope, and Audio-Video. I spent most of my career in the Microwave Division, renamed later in 1970, the Stanford Park Division. I used to present this following material to new employees in our divisional orientations, and to the newly-hired field engineers in their neophyte seminar. It consisted of a narrative of the division organization, plus a graphical genealogy chart (see below) of most of the early HP products and their genesis from 1939.

The Microwave Division (MWD) had a rich tradition within the Hewlett-Packard Company--both in successful products, and in organizational philosophy. As HP grew through the 1940's and 50's, operations were contained within one group of buildings at 195, 295 and 395 Page Mill Road in Palo Alto. Those buildings were used later to house the Palo Alto Fabrication Center, before being torn down in about 1998 to make room for Agilent Corporate headquarters. The move to new "sawtooth-roof" buildings (1-6) at the top of the hill in Stanford Industrial Park took place about 1957.

Management style was informal, the product line was relatively small, and customers were clustered predominantly into the high-technology (aerospace) marketplace. In a word, life for HP was simple, at least compared to dozens of later divisions and operations scattered around the globe, and involved in many business sectors.

During the late 1940's and early 50's, HP's product line broadened considerably. The original audio-video products such as test oscillators, voltmeters and distortion analyzers, expanded with RF and microwave equipment, which emerged from the post-WWII national research activity. HP purchased a few microwave products from Varian Associates of Palo Alto. Digital frequency counters, first capable of 10 MHz, then 220 MHz, and 12.4 GHz measurements were introduced. Finally, in 1956, HP made a commitment to enter the oscilloscope business, and, by 1960, had a full line of oscilloscope products to compete with the industry leader, Tektronix.

HP's central business strategy was then, as it is now, to develop innovative new products, which fill a measurement need. But the resulting proliferation of product lines was

creating many problems, in managing different product and business strategies. In 1958, to provide more specialization, the centralized Corporate R&D Lab was divided into 4 product groups; audio-video, counters, microwave and oscilloscopes. Marketing and production remained centralized, for the time being.

HP's total worldwide business, in 1959, was \$47.7 million, and that year's catalog boasted 165 pages and 150 products. In that business era, students of management knew that most companies passed through a critical organizational phase at the \$50 million sales plateau (in 1960's dollars). This happened as management responsibility transferred from direct founder control to another necessary layer of upper and middle level managers. Separating HP's R&D Lab, thus, became the first step in transferring responsibility to those new division managers; Bruce Wholey, Microwave, Al Bagley, Frequency and Time, John Cage, Audio-Video, and Norm Shrock, Oscilloscopes.

Focusing on product line strategy in the separate design labs worked well, and by 1962, the company's sales had grown to \$109 million. Manufacturing operations expanded to Europe and Colorado, and a few outside acquisitions of related technology companies was taking place. Several of these were the Boonton Radio Company and Harrison Laboratories (New Jersey), the Sanborn Medical Equipment Company (Waltham, MA), and Moseley X-Y Recorders in Pasadena, CA.

In 1962, a major reorganization took place, and full operating division status was established for the four major product lines. Microwave Division was one of those four "Charter Divisions," at that time comprising products with annual sales of approximately \$20 million. The line included signal generators, sweepers, power meters and coaxial and waveguide test equipment. That year also happened to be the beginning of a 2-3 year business recession, so that the microwave revenues were virtually constant for three years.

Bruce Wholey, later Vice-President of Corporate Operations, was appointed General Manager of the new Microwave Division. About a year later, Bruce moved to Boston to take charge of the newly-acquired Medical Operations. John Young moved up from Marketing Manager, to become Division Manager. John managed the Microwave Division for about 5 years, then progressed through various Vice-President positions to become one of our most successful HP CEOs for some 15 years.

The Microwave Division really hit its stride in the 1960's. Dramatic new HP product lines changed the face of industrial microwave measurements. In 1964, the HP 8551 Spectrum Analyzer put HP into the spectrum analyzer market. In the process, it expanded the market five-fold, since it made measurements in ranges that previous analyzers could not reach. In 1967, the HP 8410 Vector Network Analyzer product line revolutionized microwave component design with the concept of characterizing the "scattering parameters" of test devices. Major innovations were also developing in signal generators, sweepers, power meters and measurement components.

"Triad" Organization. Successful product strategy is always critical to success, but perhaps much more crucial to long-term HP success, was a management innovation started by Young in the mid-60's. This innovation became MWD's well-known "triad" management concept, which provided the key organizational ingredient in focusing a product strategy team on product planning, for that particular product line. The three-person product team came from marketing, R&D and production. This resulted in the "Wednesday morning product strategy meetings," which assured continuous attention to this most-crucial management function. We began with 4 product triad teams.

The triad product teams devised the product strategy, based on their combined knowledge of the market, applications and production technologies. Then, in the Wednesday morning review, they presented the strategy to upper-functional management for approval. This process contrasted to many organizations of that time, where product plans came from upper management or some central planning group. The genius of the MWD arrangement was that the best creative ability of all those young team members was utilized, and yet the overall insight of the division's marketing and business upper management was also brought into the plan during the reviews.

Since those years, the strategic product plan and its weekly meeting became common practice in most all HP divisions. More importantly, personal initiative and creativity was encouraged and rewarded at lower manager levels. Relatively young first-line managers assumed an active part in the business direction, and learned to make important product decisions.

Many of those young triad managers of the 1960's learned well on those microwave teams, and went on to become division and top executive managers all across the corporation. The names of some of these young marketing product managers of the 60's will be recognized as later leaders of our company: Ned Barnholt, Dick Hackborn, Doug Chance, Al Steiner, Harold Kramer, Scott Wright, Brian Humphries, and many more. Many others came from the MWD R&D and manufacturing areas, with names like Dick Anderson, Tom Louhon, Dave Weibel, and perhaps dozens more.

Sales of the Microwave Division grew to over \$100 million by 1973, and all other divisions in the (then) Instrument Product Group had moved out of Palo Alto. Since long HP experience had shown that optimum division size was in the \$50-75 million sales range (for that period), a division split was executed and we received a new name, Stanford Park Division (SPD). Plans were made to reassign the rather broad line of products that were manufactured in Palo Alto. Not all of these were microwave, but they were located in Palo Alto, partly because of the highly-sophisticated metal and plastic fabrication shops, that were located at 295 Page Mill Road.

The computer-operated microwave system product line transferred to Automatic Measurement Division (AMD) in Sunnyvale, microwave OEM components to the Microwave Semiconductor Division (MSD) in San Jose, tape recorder products to San Diego Division (SDD). The largest transfer

was network and spectrum analyzers plus sweepers to the newly-formed Santa Rosa Division (SRD).

Once again, and re-starting at about \$50 million revenues, the remaining products in the Stanford Park of the 1970's grew fast. The line included signal generators, power and noise figure meters, transceiver test equipment, and coaxial and waveguide measurement accessories. High performance solid-state generators like the HP 8640 and 8660 replaced tens of thousands of old HP 606s and 608s and drove business upward. Meantime, brand new products like the HP 8901A Modulation Analyzer and the HP 8950A Transceiver Test System zeroed in on customers who were equipping production lines for CB radio and mobile FM radios. The HP 8672A Synthesized Generator (2-18 GHz), introduced in 1977, began to amaze everyone, with how many hundreds of customers needed that \$30,000 instrument.

By 1978, it was obvious that floor space was again running out at SPD, Palo Alto. Spokane, WA, Division was established, and plans were made to transfer the signal generator and transceiver test products below 1000 MHz, in a 3-year phased move. By 1981, most of the people and products had transferred. Soon after that, the Manufacturing Division (03), at the old 395 Page Mill site, Palo Alto, was re-integrated into SPD. (It had been spun off from the Microwave Division in the late 60's.) This put SPD back into major fabrication operations, making cabinetry sheet metal, plastic parts, and aluminum foundry operations for the entire corporation. And the huge printed circuit board fabrication, of Bldg. 15, was added, too.

The Stanford Park of the 1980's was primarily a microwave division again. Its products and markets found great potential in communications, radar, navigation and defense electronics. In addition, our products went into many other scientific and industrial sectors, from radio astronomy to drying plywood glue with microwave energy. The aerospace/defense business and satellite communications, in particular, grew rapidly in the 80's. And the international sales operations of HP accounted for an increasing penetration of world-wide markets.

As the 1980's grew to a close, consolidation plans removed the Palo Alto Fabrication Site to a corporate fabrication group. Then the Microwave Test Accessories (MTA) product line was combined with a similar product line from the NMD division in Santa Rosa, and the new business group attached to the Microwave Technology Division (MWTD) in Santa Rosa. By the end of 1990, marketing for MWTD had moved, and production was transferred out over several years.

Stanford Park's future in the 1990's was exciting. Microwave system technology had changed dramatically in those years, with the increased availability of ultra-complex devices and components. These customer changes led SPD to introduce two innovative new approaches to signal simulation, needed for testing these modern communication and military systems.

One direction away from the traditional AM/FM/Pulse modulation was called Vector or I/Q Modulation (which stands for In-phase and Quadrature). This digitally-oriented modulation format was increasingly used in modern microwave terrestrial and satellite communications. It is a

very efficient use of the government-regulated frequency spectrum, and it permitted direct compatibility with digital signal formats such as computer data and digitized voice channels. The resulting products, like the HP 8780/82A Vector Signal Generators and HP 8980/81A Vector Modulation Analyzers, served for years with the highest performance, and without competition.

The other direction in modern signal simulation was the so-called frequency-agile signal generators, which matched up to new trends in radar and electronic-warfare system designs. SPD accomplished that with state-of-the-art technology called direct-digital synthesis. The HP 8770A Arbitrary Waveform Synthesizer (0-50 MHz, AWS) was launched first, followed by the HP 8791 Frequency Agile Signal Simulator (HP FASS), which at \$225,000 each, represented a remarkable cost effectiveness for those system customers.

Several other product directions were the HP 11757A Multipath Fading Simulator and the HP 11758T Digital Radio Test System. Both of these directions were intended for field installation, commissioning and preventative maintenance of modern terrestrial digital communications radios. This market sector was still growing rapidly in support of digital cellular mobile communications, and became a massive worldwide trend.

Functionally, our products were used by design engineers in R&D Labs, by manufacturing engineers for production test, by evaluation and environmental engineers for quality control, and by engineers and technicians in service and maintenance facilities all over the world. Over 50% of our business then came from outside the US.

Typical applications would include signal generators used by FAA technicians to calibrate air traffic control radars used at most major airports. Our power meters were used to test microwave link transmitter outputs at a telephone company production line. A NASA design lab might have used our HP 8673B Synthesized Generator to characterize a telemetry receiver for the space shuttle. The HP 8970B Noise Figure Meter was used by component design engineers to produce better low-noise amplifiers for satellite earthstations.

The SPD Vector Generators were used in design labs of microwave radio manufacturers. The new HP FASS had been purchased for creating real-life electronic scenarios, to test radar and electronic warfare receivers, while still at the design bench in the lab, using a software library of realistic electronic threats. The HP 8770A AWS could create complex test signals which included desired signals, plus all manner of signal impairments, to test the read/write head electronics of high-tech computer storage disks.

SPD products were top-of-the-line. Brand recognition surveys of microwave customers consistently ranked HP signal generators near 95%, and power meters around 85% (these numbers were share of mind, not share of market). For HP's high performance and quality, customers were always willing to pay top dollar. (End of SPD profile.)

I always viewed my Marcom job as having a cheerleading component. I would point out, to anyone who would listen,

that our outstanding HP reputation was a fragile thing. Customer orders made our world (and paychecks) go around. We didn't deserve these orders. We had to earn them, continually, one by one. And that every SPD person must help. Our reputation rides on high quality products of today and tomorrow, not on past achievements

So, you can see I was trying to convince our new employees and field engineers, to understand the high regard we earned with our customers. I wanted them to know that reputation was a crucial part of our business. And that everyone from the production person, soldering a PC board, to the shipping clerk, could affect our quality of the product inside the shipping box, upon opening by a loyal customer.

The financial model of HP operations through those decades was quite consistent. R&D expenditures were set to 11% of revenues, 9.5% to the division R&D and 1.5% to corporate R&D.

“Return factor” of a new product, measured by a 5-year accumulated product profits divided by the project R&D costs, was set above a factor of 3,

Prices were set to deliver a gross profit of 22%, 2% going to profit sharing and 2% to the employee pension plan, with 8% going to corporate taxes.

Then, in a going-organization, such a company could grow at a rate of 15% per year, without having to go to the external finance markets for funding. Internal profits would throw off enough profits to sustain internally-funded growth.

Interestingly, when V.P. Frank Cavier plotted HP growth charts for almost 3 decades, it showed an average of just 15% per year, higher some years and lower on others, but on the 15% trend line. And for you scientific folks at HP, it was symbolic of the operation of the company, that when averaged over many years, the average return factor for new products came out to a number close to π , 3.14.

There was no equality between divisions, however. For highly-competitive product lines like oscilloscopes, marketing expenses as a percent of revenue, were often 8%, with advertising sometimes approaching 3-4%. In a market arena where HP owned the customer preferences, like RF/microwave, marketing expense was limited for years to approximately 2.5%, with <0.5% for advertising. It seemed unfair to our lab engineers, but for the good of the overall company, and its customers, Dave and Bill determined those relative allocations personally.

A digital future for the Stanford Park Division. I added this short description of the SPD to VID transition in Rev #3.

After serving for decades as the mother division of RF/microwave technologies, Stanford Park Division was assigned a new role for the 1990's. The original Microwave Division had created the Santa Rosa Division in 1970, and the Spokane Division in 1980, and had moved many other successful products to the systems and recorder divisions. At a time of dramatic change in the video recording and distribution technologies, the decision was made to exploit

some of HP's technologies in the video test business. Digital techniques had come along so fast, that digital video was certain to take over that huge business.

Video technology hadn't changed all that much in the previous 4 decades. It was analog and video cassette tape technologies which dominated things. But with the digitization of video and the inroads of computer disk technology, both hard disks and CDROM type media, important marketing successes were out there. Jim Olsen took over as SPD division manager from Al Seely a couple years before, and took charge of the transition.

It was a major paradigm shift for the staid and traditional microwave team. The new division was called Video Instrument Division, and aimed its resources at broadcast video applications and post-production areas and the cable distribution markets. Major technology inroads were made, especially in video streaming servers, which were distinguished from ordinary computer data servers which merely served up batches of data. Video servers needed to stream continuous video data, and relied on highly-sophisticated data compression technologies like MPEG. Experts like Al Kovalick made significant contributions to digital video compression.

The VID Division learned how to play with the big-boys in the media game. For example, the major trade show of the industry was the National Association of Broadcasters (NAB) show in Las Vegas every spring. It involved 15 acres of booths, major flash and flare, 150,000 attendees, and a week-long chaos of publicity events and hooplah.

After 5-6 years of heroic engineering and marketing efforts, we had succeeded in fielding a line of Video Disk Recorders, MediaStream Broadcast Servers. We had also shipped a Video On Demand (VOD) cable server to PacBell for use in streaming up to 10,000 video signals to telephone customers, who could order up any video they wish, start, stop and pause just like a VCR. The VOD was ahead of its time.

Sadly, after all that hard work, HP management concluded that the product line didn't fit our field sales coverage, and sold off the business to Pinnacle Systems in Mountain View, CA. A large team of engineering and marketing people went along with the products in the buyout.

Affiliate Divisions. Before HP went public with their stock in 1957, the corporate ownership was a partnership entirely in the hands of Dave and Bill. Before that, they had determined to award a number of key employees and middle management, stock positions and options in those several HP affiliates, which supplied parts and components to HP.

HP Associates (HPA) was set up for working the technology in the semi-conductor arena. Some outside scientific talent was recruited from RCA and other leaders of the time.

Palo Alto Engineering (PAECO) manufactured power and highly-sophisticated signal transformers for HP production.

Dymec was established to engineer and market custom systems for sophisticated customers in aerospace and

manufacturing applications. The strategy was to leverage the use of individual HP instruments, coupling them into measurement or generator systems. The objective was to supply “turnkey” systems that most HP production lines were not equipped to handle. Most aerospace companies did not normally have the extra engineering resources available to take away from their main military system production, so there were advantages to buying turnkey system testers.

Dymec’s original name came from the fact that “hp” turned upside down was “dy.” I believe that they took those two initials and added “nac” to make Dynac, which was to stand for dynamic acquisition and control. Shortly thereafter, Westinghouse, which owned the name Dynac, objected legally, so the name was changed to Dymec.

Dymec moved strongly into computer-operated systems as the HP 2116A instrumentation computer rolled out. It was a natural for complex measurement and control systems. Dymec also moved into real-time production measurement systems which required faster data sampling than offered by the standard HP product like, so they designed special “system” digital voltmeters and fast D to A generators. They also designed some special microwave signal generators and test sets that had quantities too small for a normal HP division to consider in their calculations of “return factor.”

As the main HP Corporation launched their first Wall Street stock, all of the manager-owners-employees of those affiliates were “bought out” with HP stock. Many became quite wealthy from those early stock portfolios.

The Product Genealogy Chart

The chart on the following page covers most of the early products of HP, but in the middle decades mostly focuses on RF and microwave.

Corporate vs. Division

In any large organization, whether corporate or the military, there is always a creative tension between the corporate staff (Pentagon) and the operating elements (military divisions). HP was no exception. For some functions like R&D, Dave and Bill set the ratio at 1.5% of revenues going to corporate R&D while 9.5% stayed in the Division product engineering, for a total of 11% devoted to research. As mentioned earlier, HP found that such an amount in engineering with a reasonably successful batch of new products allowed HP to grow at about 15% per year without the need for outside financing.

Many of the important functions of any corporation MUST be done in a central group. Examples of this would be IT and certain finance and tax functions. And certainly the Comsys communications system described below, was a grand success. But there can be an arrogance that develops in central functions, especially when their funding comes from a highly-reliable source they can count on, or what we in the divisions used to call our corporate “tax.” On all of our costing analyses for new product’s prices, corporate overhead was one line item. It was about 4.5% of revenue, a considerable amount.

When the corporate functional groups were scattered around various locations in Bldgs. 1-6, 15, 16 and 18, on the hill, there was considerable interaction between division and corporate people. It happened at coffee discussions, and just running into each other in the halls. But by the time that Bldg 20 was built in the 70’s, and many of those corporate groups consolidated into that “Hanover Street” site, it was a huge operation. I think someone said that there were 2000 people there. I can recall John Young observing in one of his management talks that not a single penny of profit was made in Bldg 20, with all those people. Therefore he set their objectives to never outgrow that building. Alas, it was not to be. Corporate overhead tends to grow inexorably.

John was actually wrong regarding profits out of Bldg 20. They did take the royalty income from intellectual property patents for HP. And the corporate component engineering group became a huge money saver. As HP grew to many global production facilities, our parts procurement became a real model for creativity and efficiency. Creative engineering teams chose long lists of preferred parts to limit the proliferation of inventory items. That didn’t mean a product designer couldn’t choose unique parts, but he wouldn’t get the advantage of low prices from the preferred parts database.

By restricting the number of parts, they achieved two things. They increased the global usage of those fewer parts numbers, and gave the purchasing guys huge quantities to dangle in front of the potential suppliers. This purchasing power resulted in large central purchase orders to fewer companies, and gave the using divisions the ability to just drop ship what they needed from the central purchase order.

More importantly, by providing these large annual commitments to fewer suppliers, HP was able to demand much higher quality and reliability specifications. It came at a time when customer attention was seriously focused on buying better reliability, which were inherent in semiconductors. So the corporate function of component engineering was remarkably successful in saving huge amounts of product cost, thereby increasing profits for all.

Other projects were not so fortunate. One program was initiated in corporate engineering, which was intended to create a template for how the design engineers in the divisions should work to invent their new products and engineer them into introduction. This albatross was truly ill-fated. Part of the reason was that the group grew to several hundred people, all without accepting suggestions or comments from the dozens of product divisions. Yet those divisions would ultimately have to accept this massive batch of processes into their engineering groups. Minimum inputs were solicited because the central group felt that such suggestions would “taint” their creative ideas for how to run a “futuristic” divisional R&D organization. Bad idea. Worse, the central group manager was impervious to suggestions, and ultimately a new manager was brought in from Loveland, who killed the whole thing, or re-directed it significantly.

It led me to observe in some of our discussions with corporate personnel that perhaps a useful control tool for corporate programs would be that every January 2nd, all 2000 people in Bldg 20 would be kept out in the parking lots. They would

THE HP MICROWAVE GENEALOGY CHART (1939-1991)

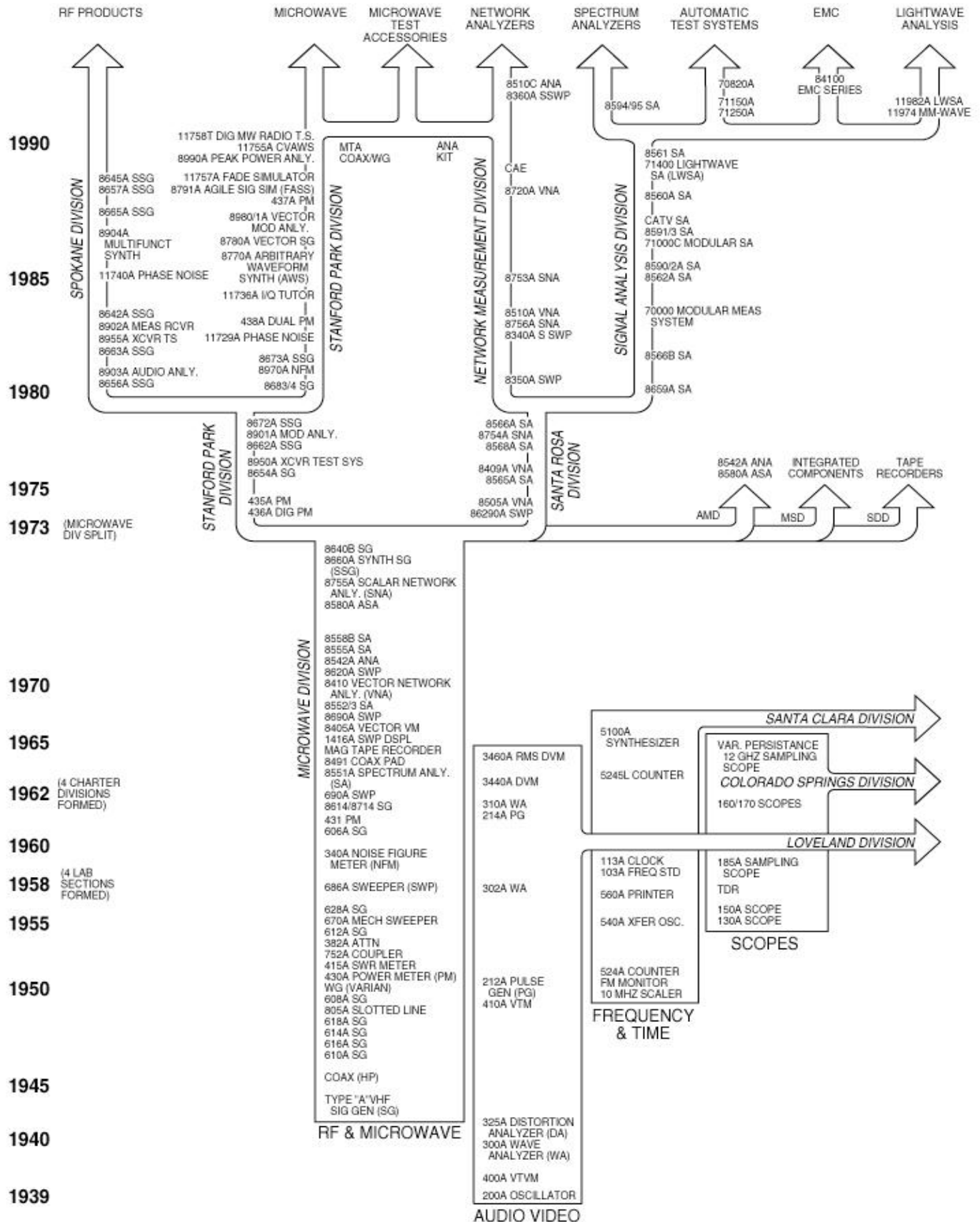

THESE COLUMNS SHOW THE APPROXIMATE INTRODUCTION YEARS FOR SIGNIFICANT MICROWAVE INSTRUMENTS AND SOME EARLY PRODUCTS FROM OTHER DIVISIONS

then appear before a panel of 5 randomly selected division managers, to present their job-function case. They would be permitted to go back to work on their projects, after justifying that they were serving to make the divisions more efficient or more profitable. For me, such a process would assure that at all times, the corporate groups would be looking to serve the divisions.

I also observed that over decades the military has devised a pretty good system for assuring that the Pentagon and operating armies work well together. They set up a routine re-assignment of officers so that they work on staff projects at the Pentagon for 4-5 years. Then they get posted to an operational army to carry out the orders of the staff work they just worked on. I was never able to see much of that kind of movement at HP. Quite a few divisional personnel moved to corporate, but almost none ever came back.

It was a personal thing for me. I loved products and applications. I was truly at home in a product division, and doubt that I would ever have been happy working on processes at corporate rather than products at a division.



The Exceptional Culture of Creativity in HP Product Engineering

For most of us who grew up working inside the product development teams of HP engineering, manufacturing, and marketing, it was not obvious that our processes for creating those new products were all that different from other companies. It was in 2006, when HP outsider and aficionado, Ken Kuhn, made the observation to me that HP seemed to spawn an exceptionally long string of highly creative new products over the years. Although Ken never worked for HP, his career in design engineering for instrumentation products sensitized him to the fact that there really is a **culture of creativity** in the product design world. He has accumulated 400+ vintage HP instruments in his basement, and created a website “museum” of HP products and historical documents. As a design engineer himself, he expressed great interest in how that culture worked at HP, and asked me for my observations. (See References at the end for URL.)

It got me to thinking, and I briefly consulted several of my long-time HP engineer associates for their thoughts. I am indebted to Al Bagley, Bob Grimm, Bob DeVries, Art Fong and others who gave me their comments. With such a record of remarkable instruments over all those decades it is too easy to think it just happening because Dave and Bill proclaimed, “Our products must make a contribution.” A recent HP historical overview, released internally on DVD, and titled, “HP Origins,” consisted mostly of interviews of several dozen retired HP middle and upper managers. Their remembrances certainly give the impression that it was top-down. Al Bagley remembers that “it was drummed into” the engineers that we would not build “commodity or me-too” instruments; others could do that.

Yet it seems to me that Dave and Bill’s “top-down” direction is only one factor in the true overall culture that drove HP people to excel in figuring the right kind of performance that

would provide a real step ahead for customers. Moreover, beyond the technical performance inside the box, there was always the additional creativity in the external feature set—the front panel controls—which reminded the user daily that they had the best machine—money could buy.

More than once customers would mention to me that HP meant “High Priced.” My answer always was, “It’s worth it.” Packard’s pricing philosophy stated that we would price for value. If we contributed to customer value, it was worth a considerable price. Yes, we did use pricing formulas, but once the minimum required profit was reached, you could price higher if there was a clear, unambiguous, or often, a **UNIQUE** measuring capability. The HP 851/8551 MW Spectrum Analyzer was a clear example of that pricing philosophy, with its exceptional breakthrough performance.

My thoughts on the factors of HP creativity of design

1. **Objectives.** The HP creativity culture did start with the top-down instruction from Dave and Bill to always make a measurement contribution. Frankly, I had not recalled any written-down guidance on the topic, but Al Bagley reminded me that the Corporate Objectives of 1961 actually stated that contributions were #1, as follows:

Objective #1

TO MAKE IMPORTANT CONTRIBUTIONS TO THE FIELD OF ELECTRONIC INSTRUMENTATION.

We have agreed that over the years we should concentrate our efforts in the general field of electronic instrumentation, and that we should direct our energies toward trying to make significant achievements in this field. This objective is precisely stated as follows:

TO DESIGN AND DEVELOP ELECTRONIC MEASURING INSTRUMENTS AND TECHNIQUES THAT WILL CONTRIBUTE TO THE ADVANCEMENT OF SCIENCE, INDUSTRY, AND HUMAN WELFARE.

In order to properly meet this objective, it is important that we place the maximum effort on our new-product program, for it is only by continually developing new instruments, new techniques that make real contributions in their technical capability, that we can build and maintain a position of leadership. *This means we must continually seek new ideas for new and better kinds of instruments.*

It is not sufficient, however, simply to discover new ideas and new concepts; we must be able to convert these ideas quickly and efficiently into new products. As the company grows larger, it is likely to be more difficult to maintain good efficiency in our new-product program. It is mandatory that we do so if we hope to maintain our position of leadership in our field.

In most cases, the success or failure of a product is determined by the care with which the details are executed. This means we must seek to develop in our manufacturing program the best and most efficient production techniques which assure at the same time *quality* and *economy*. A

customer who buys an instrument from the Hewlett-Packard family must expect to get the finest of craftsmanship and the best in value for his money.

And, finally, in order to make a real contribution in our field, we must provide our customers with the best possible service. Again, when a customer buys an instrument from the Hewlett-Packard family, he should expect not only that it perform well the day he receives it, but that it be designed and backed with the best possible service so that he can expect long trouble-free operation from his instrument.

These are the elements of excellence we must concentrate on in every level of our organization and seek to do the best job that can be done in each of these important areas.

Objective #2.

TO MAKE A PROFIT ON ALL CURRENT OPERATIONS
(end of excerpt)

It should be noted that soon after 1961, that the profit objective was raised to #1. H and P observed often that profits result if contributions come first, and all other operations were done efficiently. Plus the observation that profit was the SINGLE best overall indicator that we were doing EVERYTHING well.

2. Product Plan. I feel that the framework for creativity in HP new products was the formal strategic new product plan, usually prepared for a 5-year forward period, and reworked continuously. I don't frankly recall serious written product plans in my earliest days of 1958, when I was an application engineer assigned to Bruce Wholey. The four R&D sections in Barney's R&D lab were run by Bruce Wholey (microwave), Al Bagley (frequency & time), John Cage (audio-video), and Norm Schrock (oscilloscopes).

Bagley remembers, "A long time ago, we used to have regular Friday morning meetings of the lab engineers. At one meeting, we were all surprised when Hewlett showed up and said he wanted to propose something new. The idea was this: We engineers would spend all day every Friday doing nothing but looking for new and innovative "blue-sky" ideas. These might not occur to us while we 'had our noses to the grindstone trying to meet our present schedules.' Wow! That sounded great, but after he and his friend reflected on it, a 20% reduction in product development time didn't really sound too good, and so the idea was dropped. It was interesting, though, that shortly later, the central HP Labs (under Oliver) was set up to use 15% of the HP R&D budget looking for totally new ideas, not part of any lab section."

Bagley's mention of 15% allotted to central R&D was for the period after product engineering had been organized into product divisions (circa 1962), and Barney Oliver retained the central corporate R&D group. That R&D group was funded at a rate that was 15% of the overall company engineering budgets, which themselves ran about 11% of annual revenues for the 1960's.

We know there was new product planning done at Barney's R&D management level, because I recall annual offsite

management meetings, where various planning slides, finance, fiscal results, future plans were presented. Barney ALWAYS delivered a stimulating presentation, with tantalizing pictures of revolutionary new product ideas to come. Of course, Barney's mission was to move HP into product areas that WERE NOT covered by the existing product divisions. They always made us proud to be on HP's team, because the possibilities were so elegant and exciting.

Soon after John Young took over the new Microwave Division in 1962, the formal product planning processes got to be highly routine. As I describe elsewhere, John's triad management organization structure and the Wednesday morning product plan reviews were key to continuously focusing on the strategic product plan. I believe that this management process was soon adopted by the other product divisions, partly because Dave and Bill were impressed with the results.

It has been asked who is responsible for developing the new product plan, marketing or engineering? Or, can that crucial job be turned over to a centralized product planning group, or perhaps even a paid consulting company? I think we all have heard of companies where product planning belonged to a central planning group. In the HP Origins DVD, it was mentioned that HP did run a consultant study to determine the market potential for the HP-35 calculator. For its own reasons, that study turned out to be dead wrong. I am sure that there may be companies where central planning could work quite well, say in food processing arenas, or perhaps pharmaceuticals.

In HP, the division's engineering department was custodian of the strategic product plan. But the responsibility for inputs was demanded from all three groups; marketing, engineering and production. Marketing was expected to survey customer needs, competitive aspects, business trends, and such. If there were new military system technologies, say on radar advances, new complex modulations, marketing was expected to be abreast of those application and technology trends.

Lab engineers were naturally watching the technologies, knowing what industry was doing in similar systems, component advances, better detectors, oscillators, amplifiers. They looked and innovated new measurement processes and techniques.

The production member of the management triad was supposed to be current on manufacturing technologies, microcircuit trends, PC processes, fabrication techniques, which could give us an advantage on production costs, or on new testing procedures they foresaw for future work.

Each product team was working 5 years out, trying to assess where the industry technology was going, military, communications, radar, etc. Having an open plan allowed everyone to contribute to ideas, marketing, sales, even manufacturing who needed better test gear for their own lines. And this was done continuously, since each product segment in the plan was re-visited maybe every 3 months. Bob DeVries emphasizes that the "next-bench" syndrome worked for us here, because every one of our engineers and customers USED test equipment every day. We could see what worked

and what wasn't working well. And the feedback was immediate.

I always felt that our mechanical designers were unsung heroes in this creativity process, during their part of the instrument design sequence. When it came time to lay out the functional front panel controls, they recognized that how you "drive" an instrument has EVERYTHING to do with the way the panel controls were presented and laid out. I think that was often equally as exciting to a customer as the electrical performance. This was especially true as the front panels began to sprout digital keyboards and CRT displays. The measurement power was often embodied by the way the front panel and the data displays worked in a measurement sequence.

3. The Next Bench. The Hewlett-defined "next-bench syndrome" was another key to our creativity. Not only did every design engineer use HP test equipment EVERY DAY, but they also lived next to other groups who were doing similar but adjacent measurements. The informal culture in the labs of HP afforded a lot of cross fertilization at the traditional coffee breaks twice a day. People did not hold their research protectively. So, measurement improvement became a challenge to each engineer. Almost a team-bragging-rights thing. They could see where productivity improvements in measurements would enhance their day, and strived to make such improvements in their next product. An HP product team that produced an industry-breakthrough got the same kind of internal management recognition as a winning sports team.

In a few cases, management permitted some actual direct competition in products. I recall at one time there were THREE digital voltmeter designs going at once. While not directly competitive functionally, many of us wondered why HP would waste resources promoting three similar products to customers. Admittedly, one was an integrating type which fit system applications better. Another was super accurate, suitable for standards labs, etc.

There was another aspect in the "critical mass" element that went along with everyone thinking of measurements every day. In the 1960s, there was an amazing breakout of technology, across a wide front. In the rf/microwave labs, as some new measurement technique came along, time-domain reflectometry for example, engineers like Harley Halverson were able to fire pulses down through the HP 355 step attenuator (500 MHz), and individually tweak the frequency response (capacitance tabs) of each of the four steps of pi-network resistive pads. Which ended up doubling the frequency range to 1000 MHz, without changing anything else. The TDR analysis leveraged any number of baseband coaxial components which could be characterized with a fast pulse.

New network analyzers permitted better component analysis using the revolutionary "new" scattering parameter process. With the concurrent sapphire microwave microcircuit technology, these design insights delivered better internal components such as filters, mixers, oscillators and amplifiers. And being assembled on a single sapphire substrate, wire bonding eliminated cumbersome external cabling connections between functional modules. So one innovation would

contribute to many others. The abrupt-recovery diode mentioned elsewhere is another technology example that moved into many different product areas.

Then came the HP 2116 instrumentation computer, making automated measurements and data correction which leveraged design and iteration. The HP 8551 spectrum analyzer revealed signal performance over super-wide bands.

Creativity wasn't limited to the lab. Packard's book mentions that creativity and "inexpensive quality" should be pushed into manufacturing too. He mentioned the "Kingman card" which was a component mounting means. This was used before the wide application of printed circuit boards for component mounting. In those days, Tektronix used ceramic strips which positioned discrete resistors and capacitors, with wires connecting to the base of vacuum tube sockets.

Rufe Kingman was the mechanical inventor who built a machine which would do the legendary comic-strip "Rube Goldberg" justice. You fed into the machine black phenolic sheets 1/8" X 2" X 12" along with a spool of thin, tin-plated, 1/4" wide brass strip. The machine punched holes every 3/8" near each long edges of the phenolic board, then slotted, pierced, cut, inserted and crimped the plated strip so that you ended up with a complete fabricated component mounting board, ready for mounting and soldering components and wires..

In all areas of the shops and fab facilities, one would find clever inventions which made some process or another more efficient or safe or speedy or better.

4. The Design Engineer. The general HP practice was to hire brand new engineers, right out of college. Over the years, we did hire experienced people, usually with specific technical expertise, as needed. But in the 1960-70s, the way we grew was mostly through a huge college recruiting program. Dozens of college interview stops, several thousand engineering students interviewed on campus, and maybe 500 invited to factory visits, all day things. Each interview team spent a lot of time getting to know the professors on campuses to get recommendations of the brightest or more creative kids. I personally was never on such a campus interview team, but did a lot of the day interviews in the factory.

Bob DeVries remembers those day-long interviews. The candidate was hosted for breakfast, set up for maybe 7 interviews, including at least one technical "stress" interviewer. They all looked for enthusiasm, knowledge, communication skills, creative and technical talents. Then at the end of the day, all the interviewers would meet to make the evaluation and actually make a yes/no hiring decision. By the time several of the team would take the candidate out to dinner that night, they usually knew if they were going to make the job offer.

I had mentioned Russ Riley in another part of my history narrative. Russ was one of the stress interviewers, and came in as a very mild-mannered person who wouldn't harm a fly. But then he would launch into some questions about how the student would solve some particular problem. It wasn't a deep technical problem which the student wouldn't be prepared for,

but something that would stand out in clear contrast just what the creativity was in the student's mind. His process of thinking. To Russ it would signal those clear signs of thought sequences, referral to first principles, etc. If Russ would pronounce an interviewee a suitable candidate, you could bet he would turn out successful.

Our MW division also had the idea of hiring what Paul Ely called "inventors" rather than "4.0 geniuses." These were people who knew which end of a soldering iron to pick up, hams, audiophiles, tinkerers, car engine buffs. We surely hired hundreds of the theoretical-leaning geniuses too, for the advanced HP Labs, and specialized technologies. I always had a hunch that "doers" were often more willing to try new things than "thinkers." Further, at every facility where we could, HP arranged with the local engineering school for a Masters program for our engineers, so they could return for the latest engineering theory and practice. This gave us a continuously improving engineering community IQ, and a pool of the latest university technologies. Typically, as at the Stanford "Honors Co-op" program, HP paid 2x the going tuition rate, so as to help offset the university overhead.

Bagley remembers that HP was an attractive company to work for, when creative engineers were looking. Our innovative engineering developments were frequently seen in AIEE and IRE Proceedings, as well as in our own HP Journal. That kind of innovation attracted the kinds of minds who aspired to those goals. Al, himself, while at Stanford was attracted by one of Hewlett's ideas which was published on the distributed amplifier, which overcame the frequency limitations of vacuum tubes by arraying individual amplifier tubes along 2 distributed transmission lines. Sadly, Al noted that HP put their focus on such amplifiers rather than launch into oscilloscope products, delaying our ultimate challenge to Tektronix for the scope market.

There was one other interesting aspect of Hewlett's attitude towards taking risks. I remember him making a point at some engineering review that we should never consider that EVERY product project would succeed. He felt that if we NEVER had any failures, we weren't venturing out far enough into the unknown. A wise command. Bagley said that ALL of Silicon Valley came to show those traits; venturesome decisions, risk-taking attitudes. These were in contrast to the once-fabled Route-128 technology centers around Boston in those years.

5. Vertical Integration. As years went on, HP grew a huge vertically-integrated operation. There were the obvious sheet metal fabrications, but also aluminum die casting, PC board fab and test, plastic molding, cable fab operations, high sophistication transformer design and fabrication. Then came semiconductor operations across the diversity of technologies; diodes, bi-polar, CMOS, NMOS, and most every variety of integrated circuits to support instruments and computer products. The availability of all of those component technologies, PLUS the technical consulting that those experts lent to the instrument designer was huge.

Highly specialized technologies were also funded, from Cesium tubes to quartz crystal labs to all sorts of semi conductors. Colorado built a broad capability in research and

production of cathode ray tubes, including such unique features as the internal graticule, beating Tek. These allowed immediate research on new breakthroughs right at the state of the art. Those things were most useful in instrumentation.

Then there was a culture of building "bullet-proof" designs, with the respected HP Class B environmental performance that every new product had to undergo before accepting for production release. Heat tests, operating within specs from -20C to +55C, and without damage from -40C to +75C; vibration, humidity, shock, etc. The mechanical product designers were the key here.

Every layout had infrared scans and thermal analysis done to make sure that there weren't hot spots and to assure that fan-blown air was properly distributed. DeVries noted that they never designed an instrument with a fan if it could be avoided. He recalled having Barney Oliver spend a day with him analyzing the performance of the 3000 volt high voltage power supply of the HP 120 scope. By making it more efficient, they were able to dissipate less power and thereby avoid a fan. An unforgettable day with Barney.

There were derating charts for each component, for example, resistors were run at 75% of the published power rating; capacitors, at 75% of their voltage rating. Semiconductors and other active components had similar derating rules.

6. The Component Catalog. By the 1970s, HP had grown a huge centralized "component engineering" team, responsible for purchased parts and which HP contracted for in massive quantities. They controlled "preferred parts," and then drop-shipped to remote facilities. Because they wielded such massive purchasing power, they were able to enforce rigid specified environmental performance on purchased parts. Those were the only parts stocked in the open stock bins. You could use "non-standard" parts but had to go through extra paperwork to justify. Interesting how such a small stock-bin rule can dramatically cut the spare parts provisioning downstream in the service and repair chain and for customer repair stocks. As HP acquired other small companies, the parts team visited the new plants and installed the HP system.

7. Memories. Here are some other specific memories of Bob DeVries who lived the design culture:

* He was "blown away" on his first day in test engineering. He was introduced to the HP open stock rooms. He couldn't believe he could just walk in and get parts or vacuum tubes or hardware of any kind, and not be required to account for it or sign a charge slip. "Where is the stock clerk? There was none."

* "We were provided with the best tools to do our job. Fine drafting tables and drafting machines. Electric erasers and office supplies readily available."

* "We had well-engineered work benches with outlets for power, large work surface, lots of drawer space for parts and tools, and drawing drawers for storage."

* "Access to our precious model shop to make prototypes in-house. We had fast turn-around times and many fine

machinists and metal craftsmen to advise us on fabrication tricks."

* "We had an engineers' "play room" for making our own parts if we so desired. We had all the fine hand tools; micrometers, vernier calipers, scales and rulers."

* "We had the HP Manufacturing Manual, a compendium of preferred design practices, a Preferred Parts Catalog, and a Value Sort Catalog. They were later computerized."

* "Later, of course, we had Computer Aided Design, almost before it was available elsewhere."

Bob was one of our pre-eminent product designers. These people were responsible for the mechanical layout and were the absolute key to the manufacturability, serviceability, and reliability. How do you partition the components on the PC boards? How and where are the boards positioned? They fought all the previously-mentioned concern about running cool. And, did anyone ever think of the lowly service technician in the customer repair department 5 years later? Yes, those designers did.

I recall seeing the internal construction of a complex RF/microwave/digital instrument (not one of Bob's designs). It must have had 30 small PC boards, each inside of its own pocket inside a large aluminum casting, which had to be done to isolate crosstalk and interference. Except, the top and bottom covers were designed to be ONE PIECE, each requiring about 45 screws to hold down at all points. Luckily a senior designer saw it early and made him break each cover into 4 or 5 parts. And more than one service tech would thank him later.

7. Always Customers. The engineering dept culture was ALWAYS directed to customer needs. When the performance specification sheet was written, product features and options always aimed to do a better measurement job. Naturally some new instruments were just performance or frequency extensions of an old product. But when some new technology came along, like step recovery diodes, which allowed phase locking of microwave oscillators, that technology spread like wildfire, as I mentioned; downconverters for network analyzers, comb generators for divide-by-n frequency dividers, etc etc.

Kaiser's Film, "How to be Creative."

And, finally, creativity being so elusive and unique, I recall a time when HP tried to do some training on creativity, which I attended. One of the elements the leader used was the showing of a Kaiser Corporation video training film on how to be creative. Kaiser was the huge Bay Area company, started by Henry Kaiser, one of the six construction companies that built Boulder Dam in the 1930s. He moved into WWII "Victory" shipbuilding and later cement and a huge healthcare operation which still rivals most competition. Their Human Resources had also attempted to train creativity into all their employees by funding this film. The film itself was interesting, because after the introduction, the authors revealed the truth; that they worked hard to figure what to tell people in HOW to be creative, and failed. So they decided

that another method would be to show people a film that WAS creative.

The end result was a charming film, which as I recall was done in cartoon media. You left the showing with a definite feeling that not only was the film creative, but that you could do the same thing, and become just as creative. After all these years, the only image I carry with me, is a person working on a project, which took him up a long flight of stairs, at each step fighting off problems, overcoming them, moving ever higher. When he finally ran right up into a ceiling, hard and unyielding. But then he discovered that the ceiling was nothing but a trap door to a grand floor above and leading upward even further.

I have often wished that I could find or see a copy of that wonderful little video film of perhaps only 20 minutes. But the advice I would give to any young engineer, looking to leave their mark on their trade, would be to be curious, be inquisitive, absorb your field with plenty of reading. Find a creative mentor, and don't let them off easy.

••••••••

HP's Advertising Agencies—The Excellent Ad Ventures of Dick and Dean

Our HP advertising program of the late 50's, was essentially Noel Eldred, the V.P. of Marketing, and Bob Orr of L.C. Cole Advertising Agency in San Francisco. As the central marketing services group, they never asked many questions of those of us out in the product groups. I was application engineer with the microwave lab, and we would usually find out about a new ad on our new product when it appeared in print. That process always contained the elements of disaster, because there were often errors of specs and message.

The HP ad agency sequence went something like this: L.C. Cole to Lennen & Newell. Then George Richardson and crew bought their way out of L&N and it became Richardson, Siegel, Rolfs & McCoy. (This made it a San Francisco and Honolulu agency but we never saw any signs of the Hawaiian part). Then, Dick Garvin and others defected to form Pinne, Garvin & Hock. Don Herbers came in later, bringing in the Peterbilt Truck account. Dick Garvin was the thread who ran through most of those early agencies. He started as a young "gofer," I think with Lennen & Newell, and ended up being the creative powerhouse in Pinne, Garvin and Hock. Bob Pinne actually came from the graphics side and Owen Hock was their financial conscience.

Garvin was a real advertising genius to work with. He drank too much, which may have led to his untimely early death. Often, after delivering some ad materials to us in Palo Alto, he would retire to the Cameo Club cardroom for the afternoon. He had a wide range of interests, and authored several books. One, the "*Crystal Skull*," told of a remarkable archaeological find in the jungles of Central America. I don't recall the details of how he found out about it, but it seems to me someone on the Peninsula was in the archeology business, ended up with the skull, and Dick learned about it at a cocktail party.

Garvin went to the trouble of trying to get it carbon dated for age, and brought it to Barney Oliver for inspection, etc. Turned out it was formed from a single crystal of probably quartz, thus having no carbon, and therefore couldn't be dated. I do remember reading the book once, but mostly have forgotten its details. I just looked the book up on Amazon, and find it is still available. There is also information about it on the Internet.

Garvin also was a jazz music aficionado, who wrote off for tax purposes his trips to the Mississippi River haunts of Lead-belly Kelly, as researching a new book.

One of Garvin's more successful ad programs was one of mine. One of my product lines was the hundreds of little measurement accessories of RF and microwave components, including crystal detectors, attenuators, couplers, etc. The corporate edict for HP ad format was full page ads and spreads. But, since I had so many tiny products, with lots of new ones, I applied for a waiver to create a fractional page series. Garvin's proposal was a vertical half page, with the title, "*HP's Small Wonders.*" The layout was constant, ½ page vertical, a product picture, model number and name, and 5 bullets with specs. We later moved to half page horizontals.

We saved tons of money, and still got lots of awareness and response. Years later, I happened to be waiting in Garvin's office, in San Francisco one day, and noticed a magazine in his book shelves from the UK. It was a recreational vehicle magazine, and as I was paging through it, I happened upon an ad in the rear, 1/2 page vertical, with the title Small Wonder. Except in this case, the product was a recreational vehicle toilet. Some sort of hi-tech thing. So, when I showed it to Dick, he just smiled and said he thought of the HP theme on his own. I didn't mind, but it always amused me to watch the doings of ad agencies.

Peterbilt trucks. One of Garvin's clients of the 60's, Peterbilt Trucks, always intrigued me. Dick "stole" the account from their previous agency, when they brought Don Herbers, the Peterbilt account manager, into PG&H. Their early Peterbilt ad campaigns aimed at the owner-operator of trucks, who was a blue-collar guy that invested more than \$100K dollars in the rig, and more or less lived in the cab. The first campaign I was aware of was titled, "*Class, You've Either Got it, or You Don't.*" The visual was one of those gorgeous custom-painted Peterbilt monster trucks, with a dazzling woman, in a classy evening gown standing alongside. Showing almost innocuously, would be a tiny pin or ring with a Peterbilt logo. Sort of like the well-known, "hidden" Playboy bunny symbol. These pictures were also used on the huge Peterbilt annual institutional calendars.

The man responsible for those photo shoots over many, many years, was Pierre Jacot. It was fun hearing him tell of the odysseys he followed, in choosing the trucks, the dazzling, custom paint jobs, the women models, and the locations to shoot this truck ad series, year after year. The lore included stories of close calls, like the afternoon they almost got caught by the high tide on the Oregon coast. They had driven down the beach a ways from the access road, and didn't realize that that part of beach filled in first. Oh, yeah, a \$125 thousand dollar truck under sea water. They barely made it out.

Corporate communications. Russ Berg came in from Scientific American, in the mid-60's, to run the corporate Communications Dept. I don't think we used the term marketing communications early on, I think it was just advertising. Ross Snyder was responsible for corporate PR, and a finer and more competent writer and magazine-negotiator and all-round gentleman, could not be found. Ross retired to his hillside wine cellar, with associated home in the early 1980's and we never found another equal to take his place. (See Ross's complete story in *Legendary People.*)

Our divisional interaction with corporate was typified by the well-known "good-taste-review." This was a standing committee, chaired by Bojana Fazarinc, a charming, tough-minded professional, who took seriously the task of cleaning up our ad agency's over-aggressive ad claims. The committee had a legal purpose, of verifying performance claims, and getting rid of embarrassing flaws which divisions tended to allow. And, it was left to Bojana to come out of the meeting, and often on ad deadline, get on the phone and negotiate with the divisional ad manager to change text which contained unsubstantiated product claims. A never ending job, which I would NEVER, ever accept. All we had to do was sit on the committee occasionally and make findings on the need for caution in our claims.

The Cloverdale Castration Carnival. In the Microwave Division marketing, Dean Abramson was our resident curmudgeon. Dean had been hired in the late 1950's, by Carl Mahurin as a service engineer. Carl was partial to ex-Navy electronics technicians, because his experience was that they came highly trained and were serious employees. Dean had been trained in the Navy's Chicago Navy-Pier technician school, and after leaving the service, he gained his BS degree at the University of California. He moved to the Microwave Division marketing group in the early 60's. His tales of Carl Mahurin's "charm school" were always fun, and Dean had a way of deflating egos. For example, when he visited certain managers, he would ask their administration person whether "His Eminence" was in.

When the decision was made to spin off the Santa Rosa Division in 1970, Dean elected to move back to the town of his birth, and run advertising and sales promotion (ADSP) for both divisions, which he did until 1974. At that time, I had done my LED work at the HPA division, and Calibration Systems work at AMD, so I assumed the ADSP work for Stanford Park. Dean and I worked closely on common ad programs, since the product lines were so complementary, and the agency was the same. I admired that man for his perspicacity. (I also always liked big words—like sesquipedalian—which means a weakness for using big words like sesquipedalian.)

Under the divisional approach to advertising, Dean and I were responsible, not only for creating the ads with the agency, but also for the budgeting and cost of the media advertising. In that role, and in cooperation with Ginny Cooper, the media buyer for the Garvin agency, Dean would hold an annual visitation of magazine sales people (called space salesmen) of the big technical trade magazines like Microwaves/RF. HP was buying up to 100 pages a year from such magazines, meaning big money. And in spite of the fact that the magazine

established and published a “rate card,” which stated quantity price breaks, HP usually ran over the highest quantity break, and thus qualified for “special and private negotiations.”

Since Dean had moved from the Stanford Park Division to the Santa Rosa Division, that annual price negotiation became known as the Cloverdale Castration Carnival, Cloverdale being sort of a distant suburb of Santa Rosa. Since their competition was fierce, Dean and Ginny got excellent price breaks with each magazine, including other free benefits like ad studies on effectiveness. I elected not to join in, although I enjoyed the cost reductions on my many ad insertions, too. I don't think I need to tell you who got castrated each year?

Back to central-control of advertising. Garvin died young, and the Pinne, Garvin agency struggled, without its creative genius. Meantime, a new central crew took over at HP Corporate. Gil Reeser brought Carol Scheifele over from the computer side to T&M Marcom Manager. They fired our previous agency, and replaced them with Satchii and Satchii, who had just been fired from the HP computer account. It was not a good time for the product divisions, because the “central command and control” got us ads like the “William Tell” 4-page insert. The ad showed a youngster with an apple on his head, a worried look, and the headline, “Close Only Counts in Horseshoes and Slow Dancing.” We inferred that they meant that HP product specifications were better than “Close Enough.”



The problem was that the ad's theme, while clever and attention-getting, didn't play at all to the international customers. They had no clue about scoring in our American game of horseshoes, and couldn't relate at all to “slow dancing.” Worse, since the central group was using the insert to introduce about 12 new products at once, it meant that our new \$30,000 synthesized signal generator got about 5 column inches of promotion. Hardly the impact that a division would have allocated.

A few years later, Scheifele retired, to marry Ben Holmes, one of our V.P.'s who started as a Neely Field Engineer, and ended as Group Manager for the medical group in Boston. Into the central group, came Kathy Babcock, who had run her own ad agency in Colorado. She structured a new, shared-management arrangement with the product divisions, calling for central formats and styles, but using divisional inputs on products and benefits.

This was a pretty good arrangement, since the guy in charge of all that coordination was Monte Smith. He innovated a powerful new process for writing down all the product attributes and benefits in a 15-page document called a PIM, Project Initiation Memo. It was a comprehensive way of getting marketing and lab people to work together on what was truly important about their new whizbang. It formally clarified all the tendencies to translate mushy attribute statements into solid customer benefits, and establish the priorities of those benefits, so the agency could know how to pitch the ad.

At a later time, the central instrument marcom group came up with a new advertising slogan, “What If?” It was a way to proclaim that our products were so creative that we were able to offer customers the ability to really dream about how HP could make their needs come true. Concurrently, the computer group had been running with an advertising theme of, “It Works!” It proclaimed that our computer offerings could make magical things happen in the world of big-time computing. So, naturally one of our divisional wags noted that we could go with a new corporate slogan, What If? It Works!” That didn't get favorable responses from the corporate folks, but it wasn't intended to.

Silicon Valley's marketing environment. Many of my fondest memories of HP marketing were involved in the interactions with some of the fabled, entrepreneurial people in the SF Bay Area. These legendary characters were building some of the most imposing product lines and brands and business empires in the nation. We look back now, and wonder where these giants of the technology industry came from, but those of us who were there, know that they all started in small ways, and grew to fit the huge responsibilities they created.

Michael Malone, and his recent series of interviews (The Entrepreneurs, on San Jose's KTEH) has showcased many of those intriguing personalities; Jerry Sanders, Seybold, etc. The TV series by Bob Cringle covering the 60-70's period on the inside stories of technologies like the PC, have also been interesting, I thought.

One of my continuing fun evenings in the late 1960's, was the monthly meeting of the PMA, the Peninsula Marketing Association. We met at Rickey's Hotel most of the time. From 1964 to April, 1969, I was Marketing Manager of HP's Microwave Division. Dean Abramson was my Advertising and Sales Promotion manager, and of course the division worked within a corporate structure for PR and advertising.

Even though Dean was responsible for advertising and PR, I loved to attend the PMA meetings. I found them very educational in marketing expertise, since the various program chairmen were able to enlist so many terrific speakers. And they were not just technology speakers. I recall Famous Amos, the young black man who started a chocolate chip cookie empire in LA. There was a man from Wyoming, who had somehow managed to crossbreed a buffalo with a cow, and got a Beefalo, which promised to revolutionize the meat industry. It had the leanness of buffalo meat with the flavor of beef.

But the important speakers were indeed from our valley; Les Hogan, Wilf Corrigan, Nolan Bushnell, the founder of Atari (Pong). Disk guys, computer guys, semicon guys, and some of the early startups in biotech, Djerassi of Syntex, Zafferoni of Zoecon and Alza. There were the prominent Ad and PR gurus of the day, Regis McKenna, and others.

Possibly the best part of each meeting was the round-the-room self-introductions. It was part of the format of the meetings. And with all those well-oiled promo type folks, it got pretty imaginative. For example, during the Nixon Watergate scandals, one man introduced himself as Maurice Stans, and said that he was in the confidential finance business---big laugh. Stans, of course, was later convicted of money laundering. Another night, one of the men pronounced that he was a doctor and was giving free annual physicals for women, in his room xxx, at Rickey's. No immediate response, until a later table, when a marketing woman introduced herself, and asked "what was that room number again?"

Fred Hoar or Dan Bellack, among others, were the Masters of Ceremonies. I recall Bellack responding to my introduction as being from HP, by stating that you could always tell guys from HP, because their ties always had a horizontal crease in them. This was true since they were always known to be asleep at their desks much of the time.

So long, Fatso. One of the most inventive ads which was used against me, was a Wavetek ad out of Indianapolis, IN. Marketing Manager Ed McDonald had a new, solid-state, signal generator, which competed directly with the venerable HP 608D VHF generator. The HP 608D was a vacuum tube model, which had made huge profits for several decades. But with limited R&D budgets, other technologies had to be emphasized, such as the new spectrum analyzer and new network analyzers, so that new signal generator developments had to wait their turn.

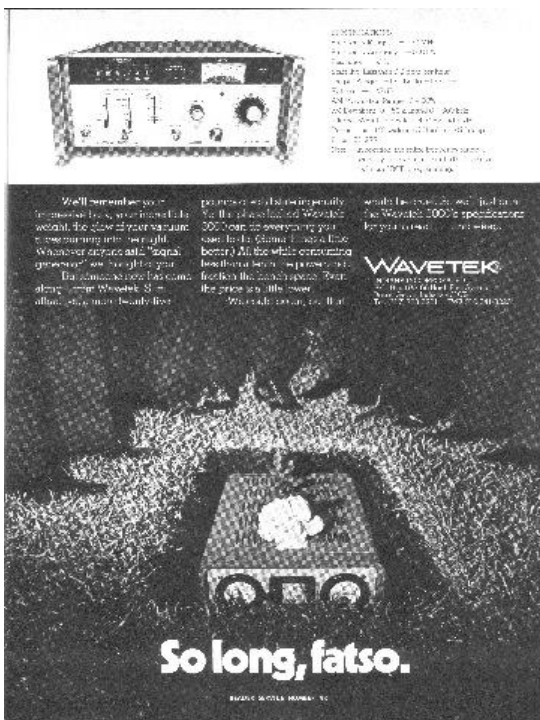

The Wavetek ad showed an open grave in a cemetery, with a number of men standing around the open pit, obviously in formal morning tuxedos, with striped pants and plaid spats. Down in the grave, just enough of the demised HP product showed, so that any RF customer would recognize the two round meters at the top of the front panel of the HP 608D, like two sad eyes.

The headline was a catchy, "So Long, Fatso!" The ad copy proceeded to strike a sad going-away message for the old HP 608. Its customers would miss his hot, glowing vacuum tubes on those cold winter evenings in the lab. And also miss his weight and bulk when they had to move him around. And other losses. There was a new kid in town, the transistorized Wavetek 3000, which ran cool, had more features than the HP 608, and would replace the HP 608 in their memory in a short time. It was an ad with a perfect punch, and it was about 3 years before we could launch our own winning HP 8640, mostly because we had to work on other crucially-important products.

That problem of getting beat by competition happened fairly often at HP. We had such a broad line of hundreds of products to support, with better and higher-technology replacements, that we often had to pick and choose the priority products to put at the top of the R&D schedules. I used to call it a process of "drowning kittens," which never earned me much respect in the eyes of cat lovers. On our family farm, when I was a teenager, literally, there were times when there were too many cats, and I guess spaying wasn't popular then. It was probably too expensive for most farmers, so the cat population-reduction process would just take place.

One specific product line that exemplified that priority system, was when the Loveland Division moved into the desktop computer sector, first with the HP 9100A and then the HP 9810/20/30. In order to pay for that massive R&D program, they had to minimize the work they were doing on audio-video instrumentation products. In a real sense though, those computers put HP into the long-term computing and printing technologies, big time, although they did result in product losses to Fluke, in the voltmeters and other instrumentation. Almost all would agree it was the right choice.

One could ask why HP just didn't go out to a bank, and borrow funds to support R&D in the old product lines, as well as the new exciting ones? Fair question, but one which flew into the face of Hewlett and Packard guidelines that HP was to financially grow from within. That meant we would only grow our business as the revenues and profits generated enough funding for buying new buildings and hiring more engineers. It was a highly conservative financial philosophy, and in retrospect, a good one. Not just that, but it was what Dave and Bill wanted.

In 1972, as Packard returned to the company after his 3+ years as Deputy Secretary of Defense, the company had gotten itself into a serious cash shortage, and was ready to take on a \$100 million dollar bank loan. This was due to some computer division marketing strategies, which postulated that HP computers should follow the pricing processes of top semiconductor companies. They argued that the right strategy

was to price low, thus “buying” market share. Profits would come later, as later competitor arrivals could never catch up with the production economies of the leader.

This process had been advanced by The Boston Consulting Group, who had been intimately involved with the marketing strategies of the semiconductor industry, where that pricing philosophy was born. This had been extended to some computer product lines, and they were being sold at less than target profits, necessitating the loan. Packard immediately quashed the loan, and cut back R&D appropriately, and ordered re-pricing of all of those products. His specific instruction was that HP priced for customer value, and NOT to gain market share for later profits. A lot of management was appropriately chastised.

•••••

Personality Testing

HP has gone through many different levels of personality and vocational interest testing. When I hired on in 1957, the marketing department requested that I take a vocational interest test, which, of course, I agreed to take. If I recall, the results said that I was best suited as an Army officer or a Certified Public Accountant. Being an engineer, I guess taking orders in a disciplined environment, or manipulating data and making the columns of a spread sheet balance, can work well in marketing. In any event I was hired.

Field personality testing. For the Neely Enterprises field organization, they had refined a method of testing potential recruits for field engineering success. What they did was to test and profile some of their “most successful” field engineers, and use those profiles to measure how new people would match up to them. The test process, naturally, tended to identify aggressive and ambitious people, mostly men. It also looked for flexibility and resilience and persistence. And it tended to exclude more passive individuals.

As marketing manager in the 60’s, I had an occasion where one of my product engineers (call him Joe) wished to move out into the Neely field organization. He agreed to take the test, which came back with the prediction that he was too bright, and too inflexible for good FE success. It predicted that Joe might become too frustrated when a customer might not see his line of reasoning, and refuse to buy. Or that he couldn’t roll with the usual punches and frustrations, caused by customers who might often refuse to buy your pitch, without any explanation. He was in the 99th percentile for inflexibility.

Well, Joe came to me to plead for another chance. I talked with the Neely manager involved, and we agreed that we would move him over to the training department (charm school) for one year. He and the training manager would work hard on increasing his flexibility and patience in dealing with the visiting customers he would train during the year.

One year later, Joe took the test once again, and I can still recall the day I received his new profile, on a sheet of paper with maybe 30 personality characteristics vs percentile. I put it together with the same paper from a year before, and held

them up to the window sunlight. Amazingly, all the characteristics matched within one percentile. I couldn’t believe that a person’s basic personality wouldn’t change much, even with all that hard work.

The outcome of all that work was that the Neely manager and I agreed that since Joe was so persistent in wanting to do field engineering, we would allow him to move into the field. But he went with the understanding that Joe’s managers would monitor his progress very carefully, and very regularly. Ultimately, Joe actually rose to district manager, controlling 6 engineers. But I am convinced to this day, that his pre-knowledge of his limitations was one key to his success. Otherwise, I believe that he would have become tremendously frustrated, perhaps even impacting his marriage or other personal elements of his life.

I was so impressed with the validity of the test process that I arranged for myself to take the same test, even though I had no interest in moving into the field. I had been solicited several times to move to the field, but I knew that wasn’t my style. A field engineer needed a sort of “killer instinct,” and needed to live that philosophy every day. I heard in one sales training seminar, that you needed to maintain the attitude that the customer, “had your money in his pocket.” Although I do honestly believe that HP delivered superior value for the customer’s money, if you were on the front lines selling, you took on a huge responsibility for delivering HP’s revenues.

In any event, I flew to Los Angeles to the headquarters of Psychological Testing for Industry Company, on Wilshire Blvd. I spent about 3 hours answering hundreds of questions. To assure no fudging, the same personality characteristics were probed with a dozen variations of the same question. To test impatience, they would ask whether I was the type of personality, who protested when someone stepped in front of me in a theatre line? Later they would ask the same thing with 10 different variations of the same questions. Thus, it was hard to cheat, because the same profile element came back over and over, and one couldn’t keep track of the way you answered old questions.

Finally, I handed in the answer sheet, waited in the reception room for 15 minutes, and was invited into the office of Dr. Bob (are you ready for this?) Reveal. Would I kid you? Reveal had only a few minutes to see the answers before I joined him, and I was absolutely flabbergasted, as he proceeded to lay out my private personality, right in front of me. I was anal, obsessive, loved to have my checking account balance, technical, somewhat pedantic, and generally impatient. It was uncanny, I have never had such revelations to what I considered some pretty innermost personality traits. So, I did learn personally, that such tests could go quite a long way to understanding which characteristics influence a person to be good at something and bad at other things.

Sales Sonics and MIR. Early in my career in the 60’s, HP sent some of us to an outside sales training course called Sales Sonics. It was owned by Larry Wilson, a highly successful insurance salesman (\$5 million a year) of Minneapolis, who had created a way to classify personalities. It turned out that such profiling was important for field salespeople, enabling them to define each of their customer personalities. That way

they knew the best human approach that worked for each different personality, and yet was an honest process which met their sales needs. For example, engineers most often

fitted the “analytic analytical” personality, which liked to be hit with data, to be comfortable enough to make a purchase decision. “Driver” personalities were usually manager-types, who liked the testimonial approach, where they heard of other success stories of HP equipment purchases.

This course was later adopted by HP corporate for personnel training across the company. It became known as Managing Interpersonal Relations (MIR). I believe that it was extremely successful in equipping our people to understand each other, and to know where they were coming from. No one personality was “right,” you were what you were, and you learned how to best deal with each of the 16 types. It worked for dealing with more than customers, it was useful for even understanding your own family relations. I truly believe that the MIR training across the company was one of the most successful and useful things HP ever did for its employees. This chart shows the four basic personalities, and each one has four subcategories.

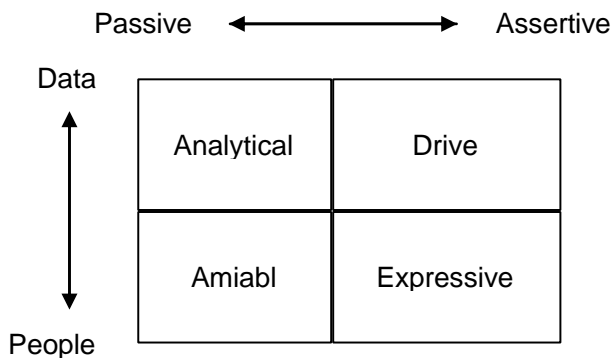

I, of course, was properly profiled into the “analytic analytical” category. Later, as the company adopted the course, and renamed it MIR, Managing Interpersonal Relations, for general training of most employees, they used to put on the course in Bldg 18, on Page Mill Hill. Since I was working nearby, over in Bldg 5U, for Stanford Park Division, they would call me over to be a “subject” person who sat in the middle of the training class. I was the test case, and was asked questions about my behavior, so that they could try to peg my classification. The thing I haven’t mentioned so far, is that although everyone has a place on the grid, you also have a “versatility index,” which all people have which allows themselves to range over into other personalities.

Well, I admit that I am really a shy person. Which would tend to point me to the “amiable” quadrant. The last thing I would ever do when younger, was to enter a party room, and start going around to introduce myself. But, as I matured in marketing and sales, I got pretty comfortable with such, resulting in a generally high versatility. So, when I was called in to the group, and asked questions, I would usually leave them all pretty confused, moving my arms around a lot, displaying a sort of aggressive attitude, etc. I guess that wasn’t entirely fair, but it did teach the students to be somewhat careful before pegging customers into a quadrant, before you had enough data. The real value of the course was

to correctly profile people so that you knew what needs were important to that style of personality.

The formal classification process involved a long questionnaire, which the subject handed out to 5 friends or co-workers, before the course date. The answers were processed by computer, and the results handed out in the training session. There were people who didn’t necessarily accept the pronouncements of MIR. One lab section manager got his test results back, which pegged him, as usual, as the typical engineer, analytic analytical. He protested that he was not such, and was pretty angry about it.

So they allowed him to re-do the profiling process. He was to choose 5 completely different friends, some from his work team, and some from his personal friends. It was no surprise to me, when the results came back exactly the same as his first process. I believe it is hard to cheat on personality testing. And frankly, there is no reason to cheat, you are what you are. I believe that the MIR program really did perform a very useful service for humanizing our personnel. It brought out the importance of the individualism of everyone’s personality, and helped our huge number of engineers to better understand how to get along with people and, more importantly, customers.

T-Labs. There was a period in the 1960’s, when the HP personnel departments had a plan to use a new personality training method called a T-Lab, which I think stood for Training Labs. It was a psychological steam bath, which lasted 5-days, under the guidance of a certified psychologist. Presumably, it was supposed to allow the enrollee to get in touch with his inner self. Trouble was, it didn’t do that very well.

I learned of the results of one person’s experience in our division, when I heard that one of our managers had returned from the one-week course, and was really in some considerable mental distress. I believe that he missed a lot of work, and later was replaced with another manager. A year or so later, one of my own young MBA recruits, who was a product engineer in marketing, requested my approval to attend. I specifically consulted with the HP Personnel Dept for reasons to approve this, and registered my great concern that it sounded pretty intense, and not something for any fragile personalities. And true to my worry, I observed that the young man did come out mentally stressed, although he was soon OK and able to carry on.

I determined to figure out why HP was approving such “training” when it seemed to be so destructive. I decided to enroll myself, for a week of stress that I never expected to endure. I drove down to the Alisal Dude Ranch, just north of Santa Barbara. There were 14 of us, and Terry, the psychologist, who never identified himself for some hours. There was Dick, the Budweiser salesman, “Casper Milquetoast,” an R&D manager for a canned food company, a man from Varian, a high-level manager from Texas Instruments (TI), a non-Mormon station manager at a Mormon TV station in Salt Lake City, and so on.

The format was just us 14 people in a small room, with few breaks, with sessions that went on about 15 hours a day for 5

days. Totally unstructured, Terry, the leader/psychologist was unidentified at first, so like any gathering of impatient managers, we started to introduce ourselves. The TI manager seemed like the most successful of the group, "I'm a mean manager, I hire and fire, and am very successful." Dick, the Bud guy, was just the genial sales type, and Casper seemed way out of place in this driver-type environment. The rest of us fell in the middle.

During the intense and psychologically stressful days, the leader occasionally would take polls on 1) Most respected, 2) Least respected, 3) Person you'd want as a friend, 4) Person you'd want your daughter to marry, etc. TI won #1, and Dick won #3 at first. But then, as the days wore on, it became obvious that TI would stab anyone in the back, and step over your fallen body to get what he wanted. So, the beer sales guy, at the end, won most of the #1 votes for everything, and we finally figured out why the TI company had sent their manager to get his edges rounded off.

Several anecdotes were memorable to me. During our Wednesday recess some people played golf. Dick was in a foursome, and happened to look behind and saw Casper, playing along by himself. Dick called him up to join their foursome, although that is not good golf protocol, and the rest of the foursome weren't happy. But it was vintage Dick, the good guy.

Since I didn't play golf, the TV older man and myself went downtown to visit the main street. He was shopping to buy a gift for his son. As it happened, I reminded him of his son, who was estranged, and I found him to be a very friendly and understanding father figure, having lost my own father at 8. Strange. We got along great the whole week.

It was almost surreal, the way the conversation would drift, from putting one person "in the barrel" and zeroing in his foibles and personality shortcomings, one after another. One night, in a particularly difficult session for Frank, a young manager, he was getting distraught, near crying. He admitted that just before he flew out to California, he had to tell his little daughter that he would be away from home, for still another week. Terry pressed him with an unhelpful question about why he was so unthoughtful to his kids and wife. Whereupon Frank did break down and cry. I jumped to his defense, and wondered why Terry would pile on, when Frank was obviously in trouble? Terry said, "Wait, John, let's just ask Frank how he's feeling." Frank stopped crying and said he was OK and he knew just what he had to do.

Then, unexpectedly, I started crying, when I realized that I was right there in the same situation with Frank, who had been ignoring his family. When he figured it out, I suddenly did too, and realized it was a serious problem with me that I had been ignoring. It was an amazing week of personal interactions and realizations.

Well, the final upshot of the week was that Dick, the Bud guy, won **all** the votes, and the ruthless TI manager was at the bottom, and unrepentant, and no doubt still in trouble with his management.

I drove home from that awful, stressful week, sort of in a daze, moving up the Salinas Valley on Saturday, in a mild rain. I was determined to do everything I could to shoot down HP's personnel department from ever enrolling any more people in that program. I survived, and perhaps even gained some perspective, but I could see that such a program, even supervised like it was, might crush young people who didn't have a strong sense of themselves.

•••••

HP Customers

In my career, I met probably thousands of customers, in visits to their factories and research and production facilities, at trade shows, and during their visits to our own factories in Palo Alto. I always saw it as a privilege to know these people, mostly engineers, because they represented our revenue stream. And I found their applications genuinely interesting and often fascinating.

I have wonderful memories of the human side of our customers. One group of US Army engineers, visiting from the Redstone Arsenal in Huntsville, AL, were in town for a large system negotiation. I volunteered to take the group up to San Francisco for a nice dinner and night on the town. I decided to host them at the Franciscan Restaurant on Fisherman's Wharf. As we walked up the stairway to the second floor dining room, we were busy talking, and I missed the tiny sign at the base of the banister.

We had a productive and delicious dinner. When the bill for \$250+ came, I pulled out my HP credit card, and the waiter said, "Didn't you see the sign at the foot of the stairs? We don't take credit cards." Unbelievable for an expense account tourist town! So I tried to offer a personal check. "We don't take personal checks." I showed them my business card from HP and offered to pay them with a company check the next day. No deal. So, the upshot was that I had to ask my customer guests to lend me the money to pay the bill, and of course, pay them back later, when I could get a check from HP. Needless to say, at many a trade show for years, they would remind me of that incident, and ask if I had brought enough cash this trip?

An important high-level engineer from the U.S. Navy Research Lab of Washington, DC was visiting to negotiate a huge development contract we had going for new signal generators. Such contracts were crucial, because they defined the technology for instruments that the U.S. military would later buy in quantities of tens of thousands. The military often shared the designs of MIL-SPEC instruments. In spite of his rank at NRL and his importance to the contract and HP, Bob was a genuinely nice person.

Bob was scheduled to fly out of SFO the following morning, so he made reservations to stay overnight at the San Francisco Hilton, which had a hotel limo pickup for the airport, early in the morning. I volunteered to take Bob up for a nice dinner in the city, and to deliver him to his hotel, along with his luggage. We parked in a garage on Bush Street, preparatory to going to the restaurant. I remember talking to Bob over the roof of the car, he on the passenger side, and I, just outside

the driver side. I was asking him whether he wanted to check in at the hotel first, or after dinner? He said after. At the same time, the parking attendant was saying something to us, which I didn't register.

So we had a nice dinner, and I hosted Bob at a another show club, and we returned to the garage at about 12:30 am. **It was locked up tight.** Imagine my predicament. One of our most important customers, without his suitcase, at 1:00 o'clock in the morning. Bob was gracious, saying that he would just check in without luggage and I could send it to him later. But I found a pay phone nearby, and called the local police station, looking to find a person's name, who owned the garage. Amazingly, they had a name of the owner, out in the Sunset district by the ocean.

By the time I reached him and woke him up, it was 1:00 am, and he was not happy, of course. To his offer to open at the regular morning time, I made him a proposition that because of my VIP customer, it would be worth a LOT of money to me for the owner to come downtown and open the garage right away. I forgot what number we agreed on, but I justified the expense on the basis that if I had had to rent a room for the night, or lease a car for a day, it would have cost quite a lot too. I guess I did get John Young to approve the extraordinary expense with some lame explanation. Bob never minded the extra hassle, and continued to be one of our most important customers until he retired from the Navy decades later. In his case, he thankfully never mentioned it again.

All-expense trips to New York. I was a pretty naïve Midwest young man, who never ceased to be amazed by my luck. Generous expense accounts for trips to Philadelphia and New York City. Every two months, I would spend two weeks on travel, visiting customers for big deals with the local field engineer. I would spend the first week in Pennsylvania, go up to NYC for the weekend, and then go to either New Jersey or Long Island where most of our business was. NYC itself had long since sent its technical manufacturing out of the downtown Manhattan.

The weekend was terrific. I could usually go down to the theatre district and visit the ticket offices and pick up a single ticket at the last minute. I had found a small deli just opposite the Radio City Music Hall, and loved to have a steak there. The waiter I always came back to impressed me once with a baked potato which had the usual sour cream and chives and butter, but he also mashed in some A-1 sauce, which I thought was superb. I went back often.

I was able to find unusual clubs and restaurants on different trips. There was the Gay-90s, a three story club with Jazz music on all floors, where one night I saw Colonel Robert Sarnoff, the founder of RCA, making a drunken ass of himself. Others which come to mind was the Stockman Steak house, which picked up people from the street with a horse-drawn stage coach that just drove along the streets of Manhattan.

I usually stayed around the middle eastside just east of Times Square. On Sunday morning, I would almost always go to mass at St. Patrick's Cathedral, nearby. When I felt like

spending two hours there, I would go to the 10:00 "Solemn High Mass." This was the full Latin mass, with the full choir, and the audio splendor of their huge pipe organ. When that organ played up to full volume, the pews shook, and so did we small humans in the pews. It was staggering. Loved it, but only a couple times a year.

Rick Alexander was one of my favorite field engineers. He was an aggressive salesman, and not always the symbol of HP integrity. For a time, he had the territory that included downtown Manhattan. After we would finish at the end of the day, he might take me to one of his favorite Italian restaurants down on the lower eastside, by the newspaper district. One of his favorite red wines was called Revello. When I got back to San Francisco, I tried to buy some Revello, but no one had ever heard of it.

In about 1970, I took a business trip to Europe, and ended up one night as the guest of the U.K. Country Manager, David Someone. He treated me to what I was told was the second best restaurant in all of London, the Mirabelle. While we were waiting for a few minutes, the wine sommelier came by with the wine list, which was a book with about 200 pages. I thought, ah ha, with this inventory, they must have Revello. When I asked him, he turned up his nose, and sniffed, "Monsieur, we do not serve Italian wines at this establishment." Later, when he found out I was from California, he turned more friendly, and commented that he respected California wines but was not allowed to sell them there.

Rick took me to dinner one night at the Plaza Hotel, which was at the corner of Fifth Avenue and Central Park South. This is the world-class hotel that is always featured in the movies with boy and girl in the park, with the horse-drawn carriages. (Think Crocodile Dundee.) They had a gourmet restaurant in the basement, with a grand circular staircase that you walked down to get there. It had a magnificent carpet that went up the sidewalls.

Our food was excellent but the service went from bad to worse, and Rick didn't tolerate it very well. At the end of the meal, he tipped the waiter I think \$1. This guy had been sporting a sort of French accent, and once he realized that he had been stiffed, he came running after us up the staircase. He grabbed Rick's coat sleeve, and muttered something about being a cheap bastard, in Brooklynese. Rick just turned and grabbed him and flung him back down the circular stairs, but because of the thick carpet, I am sure he never hurt himself. But, it reminded me of just another New York incident of brusque people.

Several decades later, Donn Mulder and I visited one of the top electronic trade magazines in Midtown NYC to pitch and demo a new product. We offered to take three of their editors out to dinner, and they chose a fancy French Restaurant on the upper East side. We were told that it was frequented by Jackie Kennedy and just around the corner from her home. It was a terrific meal and service, and I put the bill on my credit card, to the tune of maybe \$375.

As we were walking out toward the door, the captain came up behind me and took hold of my elbow, gently. "Was there a

problem, Monsieur?" I replied that I didn't think so, and that we had enjoyed the food and atmosphere. He said, "But there was a problem, Sir, with the tip." And I said, "I don't think so, because I left a generous tip. "But there was still a problem, Sir." So I said that he was just going to have to tell me directly what his problem was because I didn't think I had one. "You forgot to tip the Captain," said he.

Turns out that on credit card slips in big cities, you get a place for waiter tip and another for captain. So even though all this guy does is stand by the table, and take dishes delivered by waiters, and put them in front of the guests, he is supposed to get 5%, and the waiters, 15%. Well, as I said, the farm kid from the Midwest needed to learn that. I won't go back to a place like that.

A hidden Nobel Prize. On one of my trips to Bell Labs at Holmdel, NJ, I don't recall why, but we visited one of their communication sites, which housed an abandoned microwave horn. That particular horn design was one of Harold Friis's inventions, when he was R&D manager for new ATT microwave communications, in their early years. If you look at the towers on top of PacBell central offices, they will feature these unusual antenna shapes like an expanding tapered sheet metal thing which opens on one side in a square window, which points in the direction they want to transmit and receive communications signals. Friis had pushed this design because it represented a parabola shape for forming the beam. These particular horns had essentially zero side and back lobes, which is very important to keep out interfering signals from false directions.

Harold Friis later came to work for HP, after he retired from Bell Labs. He was a brilliant engineer, and was perfect for helping train our new engineers. His job was to browse around our microwave lab, and look in on each engineer, and provide advice if they needed it. He was amazing. I would occasionally watch him at work. He would get a complex problem from a young engineer, and just start out by deriving equations from basic principles and and his memory. It impressed the new engineer that the thought process was the important thing. He would typically come out for the winter, and return to New Jersey for the summer. He was the father of a microwave amplifier performance factor called Noise Figure.

Later, when they started the early communication satellites research, they built a huge version of his horn, maybe 35 feet long. But this time laid it on its side. It was on gimbals so it could be pointed in any direction of the sky. The reason I mention this is that that very horn was involved in a Nobel prize. It came about because two Bell Labs engineers were starting to work on another satellite project, and were given permission to rehabilitate the old horn, which had sat unused for a decade. When they turned it on, they had available some new super-low-noise amplifiers. But after installing them, they found that there was an inextricable background noise presence of 3.5 degrees above absolute zero (Kelvins) coming through. They spent weeks cleaning the horn of bird droppings and checking every soldered joint for signal losses which would show up as noise. All that did not solve the problem.

Here is where the serendipity comes in for science. One of the engineers went to a technical conference of physicists who were working on astronomy. He just happened to be standing by a coffee table at a break, when he overheard an adjacent conversation. One man mentioned that his study indicated that **IF** there were a universe-creating Big Bang, 15 billion years ago, it would have caused a lasting radiation effect. This would show up as a 3.5 Kelvins residue temperature in EVERY direction of the sky. Bingo. Can you imagine the mental gyration that engineer went through right at that moment? The upshot was that after substantial measurements and checking data and writing their findings, some years later he and his associate were awarded the Nobel Prize for physics. I love that story.

World travel. In all my 37 years with HP, I only took two business trips outside the U.S. In 1971, I took a trip to Japan, with the objective of selling our new light-emitting-diode display technology to their calculator manufacturers. We had arranged for the field engineers to set up high-level management talks with the idea that their organizations usually insisted on getting their top managers to approve any purchase decisions. We got extensive briefings ahead of time to understand that you might spend 1-2 hours just sitting and getting to know the people personally, before going into technical discussions. It drove me crazy. But we did depend on our HP country manager to lead interference for us. He was a graduate of the University of Tokyo, the most prestigious educational institution. Their graduates were a small fraternity which ended up running most of their country politics and industry.

I found that culture hard to accommodate. I know it had developed out of centuries of their custom. And certainly I went along with it, but it seemed such a waste of time. Naturally, our field engineers had to absolutely respect those customs, and we did too. After 3 weeks of traveling and Japanese food, I must say I yearned for a steak. So on my last night in Tokyo, I went out for dinner with Art Fong, one of our top Microwave Division engineers who had been posted over their for 3 years to bring some U.S. technology to the YHP Division R&D. Art and I went to Tokyo's Ginza Strip, and ordered an American type steak. It cost something like \$75, and was pan fried in butter. Not my best meal of the trip, but better than sukiyaki, I thought.

Worse, we never convinced a single calculator manufacturer to buy into the LED displays. Some years later, of course they not only built them in, but many companies went into competition with us. I think we did sell some of the technology to a railroad traffic control manufacturer, who put the displays in their large wall-sized train status boards.

My other overseas trip was to the UK and Germany. I had been scheduled to visit customers in France, but there was imminent danger of a general transportation strike, and I was warned if I got in, I might spend a month there. I also visited Geneva. My main memory of Switzerland was being introduced to "Fondue Chinese," which was similar to regular fondue, except that it used a boiling pot of water instead of cheese or oil, dipped thinly sliced sirloin strips instead of bread.

Military customers. I guess one of the reasons I loved marketing and applications engineering was that one was always encountering dramatic new technologies of customers. I found the military applications very fascinating, mostly because the funding available was used to exploit the highest technology capabilities. One example was the sequence of electronic warfare in the fighting of the Yom Kippur war between Egypt and Israel.

The Israelis sent small remote-piloted vehicles (RPVs) over the battlefield, powered with chain saw engines, and outfitted to emit electronic signals that mimicked an attacking F-4. The Egyptian surface-to-air (SAM) sites turned on their radars to illuminate the attacking "threat." High overhead, out of SAM range was an electronic warfare aircraft called a wild weasel. They detected the SAM radar threat radiation and fired a HARM (High-velocity Anti-Radiation Missile), which seeks out the source of the SAM radiation, and blinds its radar.

Meantime the ground control scrambled the Egyptian MIGs, to intercept the "incoming" attack fighter-bombers. But the Israelis had communication-jamming aircraft loitering along the horizon, and transmitted noise to effectively cut off ground communications to the protecting fighters. In Egypt, their military used the Russian order of battle, which stated that their fighters were to fly under ground orders, and not use their own initiatives to seek out their threats. When ground control was lost, the orders were to fly in circles to wait for orders. That made them sitting ducks for other Israeli fighters with heat seeking missiles. I only used this example because you can guess that the American version of all that technology was ten times better, which it was.

In the industry jargon it is electronic warfare, consisting of radars, radar countermeasures, and counter-countermeasures. And in each functional operation, there is a profusion of radio frequency and microwave signals to be used to accomplish their mission. Old traditional radar signal formats changed dramatically, so that our test instruments had to advance to handle the frequency-hopping and spread spectrum formats which resisted jamming.

Then there was the exploitation of the entire world of satellite technologies. There was MILSATCOM, a monster switchboard in the sky, capable of interconnecting strategic and tactical formations for command and control. We all know of the performance of the Global Positioning Satellite (GPS) with its ability to determine position anywhere on earth to a matter of a couple feet. It was originally a DOD funded program, degraded to allow it to serve civilian functions, until times like wartime.

Surveillance satellites served the cold war against the Russians by flying several hundred miles up with exceptional cameras in a satellite as big as a school bus. The early ones had means of encapsulating exposed photographic film, throwing it out, slowing it with a small thrust rocket motor, and catching the parachute capsule somewhere over the Pacific. Later versions used completely digital imaging with unbelievable resolutions. Even the early ones could read license plate numbers from 200 miles up. They also could monitor wireless telephone connections in the adversary's hometown.

While some of us had national security clearances, you could find out much with just commercial contacts. For example, there was a professional association called the Association of Old Crows, some 40,000 individuals working in electronic warfare, with two of their own trade magazines. The name derived from the WWII flying personnel who flew on signal surveillance aircraft, and called themselves Ravens, being crafty old birds.

The AOC's local group had unclassified monthly meetings with informative presentations that discussed a lot of current technologies. The Bay Area was home to several dozens of companies working in that field, large like Lockheed and SRI, to small firms working on highly-specialized technologies. All their work gave massive capabilities to the fliers who risked their lives in wartime.

Another professional organization I belonged to was called the Armed Forces Communications and Electronics Association (AFCEA). This was an even larger group of engineers working on every conceivable manner of military communications. It ranged from tactical jeep to jeep to satellites and fiberoptics for fixed installations. There were major computer overtones too, since most of the 4Cs, Command, Control, Communications and Countermeasures were based on complete computer control of the links and databases that were used. One prominent local example which commuters saw every day was the "Blue Cube" at the intersection of routes 101 and 237 in Sunnyvale. Surrounded by 4 satellite transceiver antennas, the equipment and personnel inside the cube were responsible for "controlling" dozens of satellites flying overhead in every direction.

The cube didn't care about the details in the communications traffic or data flowing through those birds, only the monitoring of "housekeeping" details. Every day they would contact each satellite several times to check on battery power, temperatures, thruster fuel supplies, transmitter and receiver performance.

AFCEA's local group also held monthly meetings to present capabilities and information on the status of their technologies and programs. I found these customer technologies highly interesting, and useful for projecting our future product design and capabilities with regard to new signal formats, etc.

Cheerleading for customers. I found that in spite of the fact that HP was a very customer-oriented company, that the growth of normal bureaucracy often distanced our employees from real life. Real life says that nothing happens until we get orders and ship the products. In the recession of the early 80's, I found the occasion to cheerlead our factory troops to help our field engineers whenever they could. I was trying to raise awareness of the need for everyone to support sales in this following article I wrote for our employee magazine, *Measure*.

YOUR TURN

Invites Measure readers to comment on matters of

importance to HP employees

"Getting the order" is the lifeblood for Hewlett-Packard, according to John Minck, advertising and sales promotion manager for Stanford Park Division in Palo Alto.

This persistent business recession the world has been going through has caused much personal suffering and stress outside HP. We see it every night on TV and read it in the newspapers, and most of us feel lucky and relatively secure working at HP.

If there is a good effect from the world recession. it is the growing awareness of the public, from politician to union member, of the critical importance of jobs. The mayor of Fremont, California. describing his city's attitude toward welcoming industry to the area said, "The quality of life starts with a job."

The important thing to remember in a manufacturing company the size of HP is that all our paychecks are dependent on a continuous stream of orders. I hope no one at HP is naive enough to think that we deserve these orders or that customers order from us automatically. We have to earn them one at a time. And in an economic time like this, each order is extremely important.

A customer order becomes a product shipment. That brings in the money to pay for the parts we buy, provides wages for all our people, buys new buildings and equipment and pays for R&D for new products for our future. It also gives HP about 10 percent profit; fulfilling our No. 1 corporate objective. But note that a customer order starts the entire process.

I think it was Noel Eldred who taught us that it was an advertising man who observed that "Nothing happens until somebody sells something." Direct responsibility for getting orders at HP, of course, rests on our hundreds of worldwide field sales people. But just like a fighting army, only about 5 percent of our "troops" are out in front selling; the other 95 percent of our "army" is crucially important to supporting the front lines and winning the war.

Each field sales person depends directly on dozens of other functional people to be effective; order processing, fleet, training, regional sales engineers in each factory, shipping, etc. Every additional minute that a field person can spend with customers due to more help by support people brings more orders.

In a company with 67,000 people, there maybe 50,000 who don't even know a field salesperson. What I would like to propose is that every one of us look at our attitude towards sales and orders. A customer order is pretty remote to a librarian stocking the book shelves, or an instrument assembly worker in a factory and even moreso to a records retention person in the document archives.

R&D engineers affect orders well in the future. Quality assurance affects orders almost immediately since a customer who receives a defective product might stop his next order.

We need lawyers to be sure HP meets laws and regulations. And we need financial people to keep accounting scores. Personnel training people teach us how to deal with people. (Did I leave anyone out?)

Important as all these thousands of functional jobs are, I assert that each of us should adopt a positive attitude towards getting orders. If you are writing a computer program to assist field sales people, the program should leverage the sales person's time to the maximum. If you are an accountant writing cost control systems for field sales, try to minimize hassling the sales rep's time. If a factory marketing person runs down to you in the shipping department late on a Friday afternoon to plead for shipping a sales demo that day, recognize that you'd be helping orders by having the positive attitude and shipping the demo.

Let's all take the attitude that we help, not hinder. In World War II, when the legendary General George Patton and his American Third Army were racing through France, he was pretty specific about his expectations from his support troops. When he sent his tanks 50 miles out in front, he expected his logistics and administrative people to figure out how to get behind the front lines with supplies and help. Can you imagine an accountant on Patton's staff telling him that some accounting rules would prevent getting fuel to his tanks?

While I can't speak for our field people, I know them to be serious about their great responsibility in these tough times to keep orders flowing month after month. Not only should we let them know we appreciate their work, but we should also give them as much positive support as we possibly can, no matter how far "behind the lines" we are.

JOHN MINCK
Stanford Park Division
Palo Alto

MEASURE, HP employee magazine, January-February 1983



HP's Social Culture

Dave and Bill understood that The HP Way included more than just the workday business activities. HP was a team of people who trusted each other, in a way few companies of the time envisioned. Most were military-style organizations, with a philosophy that developed out of the WWII successes. The "Whiz Kids" in the Robert McNamara Pentagon Production Office, who invented the concept of "Operations Research," pioneered the idea of central control of inventories and production. But, they ignored the value of people in the trenches who yearned to exercise their creativity. That method obviously worked well in wartime.

But Packard often mentioned, in his explanation of The HP Way, that if you tell people your objectives, and trust the honesty and integrity of your employees, almost everyone will give you far more effort than if you send down

commands from a central department. That was the principle of Management by Objective (MBO).

Early HP was like a family. Christmas parties were organized, with Packard handing out the bonus checks to the crowd. Actually that practice eventually was called off, because too many employees were arriving home long after the party, somewhat drunk, and some portion of their bonus check spent.

The traditional summer picnic became a fun day for whole families, with wonderful food, games and a variety of horse rides and ball games, etc. HP bought the real estate for many picnic sites in nearby mountains, around the world. There was Little Basin near Palo Alto, Estes Park near Loveland in Colorado, and more.

One interesting cultural difference resulted when HP tried to install the family picnic in the YHP operation, in Japan. John Brown was the co-manager for the division, on assignment from the U.S. Long prior to the week of the picnic, word went out to all employees that the employee's whole families were invited and supposed to come. But, on the day of the first employee picnic, only employees came, no families, no kids.

Brown was furious, because the value of getting employee's families into the mix was crucial. So the next year, he was extremely vocal in stating that there would be no excuses. It was causing such a cultural divide that an employee committee was sent in to see him, to try to persuade him that Japanese custom didn't permit wives and children to join men in company affairs. So, he had to make it a direct order, with serious consequences if not followed. That worked, because his employees observed direct orders, and took them to be more important than their learned culture that excluded their wives and kids. Needless to say, future picnics were highly successful, and the cultures "intermarried."

Community service. Dave and Bill wrote a series of company objectives, and adapted them over the years. One was to give back something of value to our communities. Dave and Bill themselves gave us their own examples. Dave served on the Palo Alto Unified School District Board, and used his cost effectiveness expertise to save the Palo Alto district a lot of capital funding. His common-sense approach to building the many new schools, needed to keep up with Palo Alto's growth of the 50's, was to force the architects to re-use the same building plans, school after school. Before this, each school got expensive design and unique structures (and big bills from the architects) for each site. Dave later served as Chairman of the Board of Trustees at Stanford.

Bill was Chairman of the Stanford Medical Center Board, and served a term as President of the International professional organization, the IEEE. Manufacturing V.P. Noel Porter served two terms as mayor of Palo Alto, working for the city in the morning, and back to HP in the afternoon. He was a dynamic force in both organizations. Barney Oliver was President of the IEEE, and he also served two terms on the P.A. School Board. It took several years for the ordinary citizens of Palo Alto to round off Barney's somewhat arrogant and intellectual style in head-to-head combat at the School

Board meetings. He ultimately became a very successful and well-liked public servant.

I have always been disappointed in the poor showing of the hundreds of other high- and mid-level HP managers, who didn't step forward to choose public service. Compared to the huge pool of highly competent managers, it seemed to me that few served. Jack Beckett served on the Metropolitan Transit Commission for more than a decade. Dean Morton was also Chair of the Stanford Medical Center. Bill Terry served on the Board of Trustees for the University of Santa Clara.

In later years, Gary Fazzano was City Councilman and Mayor of Palo Alto. And a small number of our Field Engineers found some calling, Earl Davis was mayor of his small Texas town. One of our Boston FEs was a village "Selectman." There were occasional finance or legal folks who led their national professional associations. There were also many top managers who were tapped to serve on corporate boards of directors, which is a sort of public service, but not the same as industrial or political volunteering.

National Conference of Standards Laboratories. In 1978, I served a year as national president of the National Conference of Standards Labs, a non-profit, international trade association of companies working on metrology. Don't confuse this word "metrology," which means precise measurements, with "meteorology," which means the study of weather and climates. These 1400 member companies were all good HP equipment customers, and the Member Delegates, who represented their companies, were all "gatekeepers," who ran the metrology and calibration and repair departments in their companies. Thus, they were key individuals in the equipment-buying cycles for their companies.

NCSL was also sponsored by the U.S. National Bureau of Standards, our Nation's pre-eminent center of measurement standards. This meant that NCSL was in the middle of important national metrology coordination work, which also happened to influence future instrumentation products and industry standards that HP needed to follow, and in some cases helped to create.

My NCSL work was a personally-rewarding experience for me. After my year as president, I have spent another 28 years editing the organization's quarterly newsletter. This has led to travel and interaction with exciting and advanced programs in science and technology. One example was a trip I made to an NCSL Board of Directors meeting in Cape Canaveral, Florida. We were able to tour the NASA VAB, the 55-story Vehicular Assembly Building, which everyone who watched the Apollo moon shots would remember.

Our host invited our metrology group into the building, and we took an elevator to the 45th floor. To all appearances, we were in just another office building. We then came down a corridor and passed through an ordinary double-door, and suddenly we were on a tiny observation deck, looking over the railing, and down 45 stories to the ground. Under us was the construction of the Skylab, a later rocket system, about 30 stories tall, used for scientific space work.

In the Apollo years, the gigantic Saturn rockets were assembled in that building. It was built with 4 huge assembly bays, so that parallel assembly of 4 rockets could happen at one time. That 45-story rocket was built in a vertical configuration, and rolled out 3 miles to the launch pad on huge caterpillar platforms, in a vertical position. It was grand, but you couldn't quite relate to being one of the astronauts, sitting on top of that monster, unless you stood overlooking that railing and realizing how many million parts were necessary to get you to the moon. But, when I stood there, I recalled the astronaut's joke about his sitting on the top of his Saturn, ready for the countdown, when he realized that every part under him was supplied by the lowest bidder. It took on new meaning.

HP lookbacks. The non-technical activities of a going organization as creative as HP people were as varied as you can imagine. Birthday parties were highly popular, with everyone taking some time off the phones and joining in the celebrations. Retirement parties down at the Palo Alto Elks Club or some other hotel venue recognized the tremendous personal contributions that some employee had made with his lifetime at HP.

Here are a couple of other examples of internal promotions that we organized for promoting the United Way campaigns. One of our most creative SPD accomplishments was to produce a promotional videotape, *"It Brings out the Best in You."* Ed Cantrell was one of our young marketing engineers, who was an experienced band keyboard player. Ed, plus a few of us created a rap video script, based on popular rock stars.

Our tall, slim Division Manager, Al Seeley, dressed up with a guitar to become "The Boss" Bruce Springsteen. Debra Dunn, our diminutive manufacturing manager, dressed up in black leather, became "Ma-Dunn-a," while stout Ray Shannon, the R&D Manager, became "L.L. Cool Ray." All the division top management of 6 or 7 took part.



Ed directed the whole thing and it was fascinating to see how he did it. He had previously done similar tapes for some religious programs. He worked with multiple-track audio, creating the background music first, with a rap beat. Then we staged each star, one at a time, playing the music for pacing, and recording their United Way pitch on their own audio track. Then Ed went back and combined them all in a post production studio. It was a terrific hit in the division, and I still have one copy of the tape at home. SPD even won a United Way award that year for the tape.

For a different year's promotion of the United Way Fund drive, the marketing department "volunteered" Eric Jennings, Marc Saunders, and me to lip sync the Andrews Sisters *"Boogie-Woogie Bugle Boy from Company C,"* for an outside barbeque event. Look at those legs—and combat boots!



HP Clubs. At its peak, HP sponsored a wide variety of employee clubs. There were the usual baseball and basketball teams with HP sponsorship in the industrial leagues. There was a sailing club, bridge club, speaker's club, HP chorus, and many more. It was kind of like the extension of our employee family.

Coffee breaks. In 1958, HP had well-defined coffee breaks all over the company. Twice a day, the chimes would ring, and everyone would leave their desks, or production people their stools, and drift to the end of the production line, where there were coffee pots and large trays of donuts or on some days, Danish rolls. I recall that some production line aluminum donut and Danish trays were set over the top of several soldering irons, set up with variable power transformers to heat them up, without burning them.

These breaks were all company furnished, and used to amaze customers, we were touring through the plants, that employees didn't have to pay for any of it. At my previous job in Albuquerque, not only did we employees have to buy our own coffee and donuts, but as it turned out, we chose to walk about 20 minutes, each way to the cafeteria, which made



it quite expensive in engineer-time, since we always figured that company owed us that walking time.

One summer we hired a young business intern, who we assigned a study task for trying to determine the real cost effectiveness of having company-paid coffee breaks. He factored in the time saved for hundreds of employees, who didn't have to walk to some central dispensing station, to wait in line for a machine, wasting production time. 10 minutes later, the chimes sounded again, and the employees were only 50 feet from their production stools.

For the office areas, and the engineering stations, he also factored in the communications value of standing around the coffee pot, and seeing people from other departments, like marketing people talking to engineering, and so forth. Managers were there, and the air was very informal. Sure, there were lots of personal experiences covered, ball games, skiing, boating, vacations, etc, but there was lots of business transacted as well. We were quite impressed that this formal study actually put numbers on the cost to HP for the outlay of food and 10 minutes of employee time. Not surprisingly, the study showed the costs to have a very high payoff factor.

In the 80-90's, it seemed to me that coffee became an all-morning thing. Many people would fill up their coffee cup upon arrival at work, and go directly to their cubicles or production places, and start working on their computer screen. And the informal and more routine meetings at the end of the line went away. Even the chimes disappeared. I felt that this was unfortunate, because we never regained those feelings of closeness and teamwork.

Office Moves. This story was triggered in Nov, 2010 by an article in EE Times Magazine, about a reader who reported a case that involved considerable difficulty in troubleshooting a bad PC board. After quite a long frustrating time, the engineer finally found out that about 1 out of every 10 of his component diodes WERE MISMARKED for cathode/anode end.

The payoff to this introduction comes at the end, but I will first describe how innovation went well beyond R&D and manufacturing. In our rapidly growing company, we moved departments a lot. So our facilities people invented several clever fixtures. To move office desks, they had a special dolly on wheels which was just wide enough to fit under the chair location. They used an auto jack to lift the loaded desk, and simply wheeled it across the floor or up the elevator. No need to empty the desk or drawers, and quite a convenient time for the desk owner.

Most of our early bookcases were manufactured by our wood shop. They were 5 feet long and when loaded with books of binders could weigh 200 pounds at least. So some inventive facilities guy made some triangular corners about 1 foot on a side, which rode about 1/2 inch over the floor on 3 wheels. To move a bookcase, they rocked a corner, pushed the low rider corner under, added the second and away they went down the aisle.

But then, in a cost-cutting change--I guess--they began to hire commercial movers. Who employed the usual mover practice

of the 6 inch high carpeted wheeled dollies. So to move a bookcase, we'd have to remove and pack ALL the books into moving boxes, and replace them at the new location. Probably cheaper for HP but using up a LOT of expensive engineer time. Oh well, of such cost cutting are management decisions made.

This new practice leads to my story of disaster. Our SPD lab stock of resistors and components, probably in the 1980s, were stored in a HUGE commercial case, maybe 3 feet wide and 2 foot deep and 5 feet high, with perhaps 20 drawers, each 2.5 inches high. Each drawer must have had 100+ bins with resistors, capacitors, etc. In those days the components had reached minimum size, with color codes barely readable without a magnifying glass.

The problem came on one move when the movers came to move the heavy component drawer stand, without precautionary instructions. They just tipped the unit 90 degrees and laid it on the carpet dolly, brought it to the new location and tipped it back up--and moved on.

Imagine the shock when the first engineer went looking for some resistors! On each drawer, probably tens of thousands of components were packed into one corner. This was the opposite of the needle in the haystack. We had millions of needles in piles. And no way to sort into values and bins.

A little like a book in a library which is mis-filed, never to be found.

•••••

Comsys

HP Journal, Sept, 1986

Among many truisms in the military, one goes something like this, "You may be promoted to command an army, but you aren't IN COMMAND of that army, until you can communicate with them." The same is completely true in any large commercial organization, and HP envisioned and constructed one of the best backbone communications systems of the day. HP's communication system, and its Comsys internal communications development is a real untold tale.

In 1958, when I joined HP's marketing department, business communications were rudimentary. Internally, it was a heavy reliance on typed memos and personal contact, the phone and the routine coffee break conversations. For field communications, written letters, telephone and the teletype were the mainstays. A lot of the urgent written communications with the field had to be done with the teletype because it left a written record. It was also known as the TWX.

Through the 1960's, under the Division Management of John Young, Hank Taylor was the Information Technology Manager, although the functional term IT hadn't appeared yet. I think it was just called the Communications Dept, and may actually have reported to finance. Hank recognized the growing problem of communications costs, sometime in the 1960's. The company's telephone and teletype bills were

growing and growing, and it was obvious that an overall system problem existed.

HP had been buying outside communications services from the local phone company, Pacific Bell, just like every other large company, sometimes using leased lines, or buying time by the minute. Then came a newly introduced WATS (wide-area-telephone-system) lines, which AT&T had rolled out to squelch the upstart microwave communication links installed by their competitor MCI, from Chicago to St. Louis. WATS was a sort of discount deal for sucking in large companies with wide-ranging telephone needs.

In the early 1970's, out of this analysis came an HP system known as Comsys. Cort Van Rensselaer relates that Rich Nielsen (now with Agilent) was the technical genius behind our early worldwide communication system. He and Hank Taylor and Bob Puette were the team that created it and made it go.

In the Comsys model, anyone would hand-write a message on a two-part form, give one to the secretary who would get it to the Comsys center, where another clerk would keyboard the message into an HP 2100 computer, acting as a router. These messages would be assembled, batched on some kind of daily schedule, and computer-routed to the appropriate field office or another division, anywhere in the world. Hard-copy delivery was typically the next day, normally delivered using the internal mail operations. This process was remarkable. And it lifted the company to new levels of capability.

But Hank wasn't done there. His vision was to engage every employee who needed to communicate with any other, into the system, years before the Internet PC revolution swept up the ordinary citizen. Once we found out how expeditious the Comsys could be, Hank moved to the next step, which was to install the keyboarding terminals into each department. Then the secretary/typist became the gatekeeper to the communications system.

At the same time, the company's global operations were being computerized with hundreds of HP 3000 mid-sized computers. Production control, materials engineering, order processing, and accounting were all migrated to rooms full of HP 3000s across the world. Email software, which was being developed as a product by HP, in the United Kingdom for commercial sale, was beginning to be available for the HP 3000. Since most of the centralized HP 3000s were often running idle, by using a small portion of their power, each entity could have the central powerful server needed for accumulating messages and routing.

One thing to remember is that HP expenditures for such massive overlay systems always demanded strict cost-justifications. But these types of overhead processes were virtually impossible to justify, so Hank had to convince, not just the central services managers, to spend those millions, but also, each of the entities, sales offices and factories of their value. Hank was really after each employee, engineer, field person, and manager, to assume the responsibility for individual keyboarding, which would be the ultimate rationale for a corporation which prided itself on technology contributions.

This system was a human revolution, because it required a lot of old timers, engineers and the older managers, to actually learn to type, or at least get comfortable with the concept of two-fingered typing, or else they would fall way behind. And as HP pushed the PC computers into the desks of individuals and engineers, the HP communications system advanced, with huge servers across the world, which moved millions of messages to keep the company on the front of the onrush of business communications. In the *HP Journal* article of Sept, 1986, the comprehensive story noted that at the time, there were 483 HP 3000 computers in 31 countries processing billions of characters and millions of messages.

The HP system was far ahead of other companies, partly because we had the computers and technical prowess to write the software for such a pervasive system, which impacted everything we did. But, it was also the people, and the managers, who could see the efficiencies which would result. The thing most of us never saw during the planning and installation years, was Hank's behind-the-scenes training and help-desk functions, which were not-so-subtly sucking us in, so we became comfortable with all these new functions. I used to brag to some of my peers in the industrial trade magazine business, that when I was organizing multi-division attendance at trade shows, or the RF/Microwave Symposium, that I could have organized the D-Day invasion of Europe, had the HP email system been available in 1944.

Following that came other communications innovations, which enabled our modern HP era. They include shared files and massive spinning disk farms, distributed across the world, which hold the very brains of the company. Data, which is the heart blood of HP, underpins our engineering and production and marketing and financial databases. They can be moved across the world in an instant. Remarkably, much of this happened before the early installation of the public Internet, because Hank and others had foreseen the need and made it happen. I should also credit Cort Van Rensselaer, who was Hank's boss, and who also fought for the financial funding for the entire program.



Some Legendary People of a People-Oriented Company

This chapter, for me, is the most interesting, because it is the main reason I wrote the book. It seems to me that as HP, and probably all companies grow large, the policies and procedures that must be implemented, to stay organized, begin to stifle creativity, and bog down the fine personal initiative of its people. Hiring becomes more "safe;" decisions become more conservative. People probably become more homogeneous.

I'm going to introduce you to some characters, who were far from homogeneous. Starting with Bill and Dave themselves, we will find a human side that cries out to be replicated in all our new people. I want all our new people to understand that they can break through the "safe" operating mode and use their creativity, challenge the bureaucratic processes, and keep the company loose and interesting and fun to work for.

You will see that most of these people are not the most “important” ones at HP, but they were surely some of the most interesting. Further, there were a lot of crucial contributors, I don’t list, who were in other divisions or cities or countries, since I didn’t have much interaction with them. There were hundreds of them. I have heard many interesting stories of other people, but I have tried to mostly only describe people and situations that I was close to, or at most second-hand. Other than Dave and Bill, these names are in no particular order of importance or age.

Bill Hewlett

Don’t lock the lab-stock room. Bill was a tinkerer. He loved to spend his time in the Lab with Barney Oliver, after Barney returned from his work at Bell Labs in the 1950’s. They were a perfect match, Barney with IQ of 180, and Hewlett with the technical curiosity of an Einstein, yet the business sense to see technology solutions and products.

It was not unusual to find Bill in the plant on weekends. Perhaps he was working on an antenna for the fly-in airstrip, on the ranch, he and Dave owned in South San Jose. On one weekend evening, he was working on a radio antenna, and needed some parts from Lab Stock. It was the late 1960’s and division management was on a cost saving initiative, which came and went, in cycles. Some manager or bean-counter decided that open lab stock was a license to steal, so the lab stockroom door had a padlock on it, after working hours and weekends.

Bill called a guard to open the tool room door in the facilities department, to bring him a bolt cutter tool. He cut off the padlock, got his parts, and left a note on the stock room door to the effect, "Don't ever lock this door again," signed Bill Hewlett. Guess how many years that that note prevented lab stock doors from being locked? Such action gets around—everywhere!

Bill's attitude was that we hire expensive design engineers, to create new products. At the same time, many have hobbies, such as ham radio or audio system design, which teach them new design tricks, useful in their regular HP job. Bill was willing to accommodate the use of HP parts, from the lab stock, to assist the engineers in their off-duty hobbies.

Bill, the home handyman. Marc Saunders tells of the Saturday afternoon, when he was shopping at the Menlo Park, CA, Hardware. He noticed Bill Hewlett, by a counter of wood screws, introduced himself, since they had met at some management review. He asked if Bill were doing some home project for the day? Bill nodded yes, but in an impatient voice complained, "Isn't this ridiculous, I just need 3 wood screws, but the way these are packaged, I've got to buy 24 of them." This, at a time when Bill's wealth was about \$1 billion.

Government work. Bill promulgated another informal process for engineers, called the G-Job, or “government work.” The idea was that every engineer was to be allowed to spend up to 10% of their paid work time, on product concepts, that might result in a saleable product, not in the official plan. This was to include necessary model shop time for building materials, or purchased parts if needed.

Probably the biggest and best example of a G-job was Barney Oliver’s exceptional audio amplifier for superior home stereo use. Barney’s design for audio amplification had unbelievably low noise, hum and distortion, which I will not attempt to quote numbers for, since I never did understand audio amplification principles. A regular production run was created, orders were written for panels and pre-punched sheet metal, plus unloaded printed circuit boards. The whole assembly was packaged as a kit, which any employee could buy, and assemble themselves. I think it ran to a second production run too, because of the word of mouth.

Another under the table project resulted in an HP product, and one that was quite unique. Frank Waterfall, of the Crossley Associates sales office in Chicago, mentioned informally to Barney, probably over a drink, that what many circuit engineers really need on their bench, was a way to measure small dc currents going down a wire, without having to cut the wire, and alligator-clip it to a milliammeter. Barney put someone on the project, and came up with the HP 428A probing ammeter. One just opened the probe, which separated a magnetic circuit, and clamped it over the wire to measure current, a very convenient and popular instrument. The meter sensed the magnetic field caused by current in the wire, using a “flux-gate” principle.

This was just the time in history, when the banking industry was creating the magnetic ink characters on the bottom of regular checks. They did this so that high-speed, computerized machines could retrieve the bank number and bank account, plus the dollar amount, added with keystrokes, from the written check document. But a problem developed in the check printing companies, because the consistency of the magnetic ink printout was often inadequate, and the check numbers wouldn’t read accurately on later processing. So one of the lab engineers, on his own time, took the clip-on probe, opened up the clamshells, and made a sensor which could detect the quality of the printed magnetic ink properties in the printing plant. It sold a large number, although it was later supplanted with simpler dynamic machines, which read numbers on the fly.

Buying the Reps. An interesting education for me, was Bill’s idea of personal and business relations. It happened in the early 60’s, during the period when Tektronix fired of all their independent reps. For a time, before HP entered the scope business, many of our independent reps also handled Tektronix. When HP decided that they needed company-owned distribution, Bill and Dave made the decision to make offers to buy all of the U.S. rep companies.

So HP bought 11 of the 13 reps, instead of releasing them like Tek did. Two declined. Sometime after, I was talking informally with Bill at a management meeting at Rickey’s in the mid-1960’s. Although I thought I knew the answer, I asked him why HP had spent something like \$10-15 million dollars for this move? I noted to Bill that Tektronix hadn’t spent a penny, but simply released their reps, one at a time, over a couple of years, to smooth the transition, and set up their own company sales offices.

His answer was, “Goddammit, Minck, you just don’t understand the situation. These reps are all personal friends.

For a decade, we did business with them, on a handshake. We owe them most of our success, in building our industry and the company, and there was no way we were going to just fire them, one at a time.” So there, John Minck! Bill and Dave regarded personal friendships with honor and integrity, and, not incidentally, backed it up with a lot of money.

Dad said its OK. One evening, I was working late in Building 3, so it must have been in the early 1960’s, and I guess it must have been about 10:00 pm. At the far end of the building, I could hear the old noisy 910 Xerox machine clacking away. I would get up from my desk, once in a while, to get a cup of coffee, and a young man was intent on building a rather large stack of copies. It grew in time to be at least several stacks, each a foot high. When I passed going to the restroom, I could see it was sheet music.

I finally put on my corporate hat, and approached him and said, “I’m sure the company doesn’t mind people doing some personal copying, but don’t you think this is going a little beyond that?” He replied, “I understand, but my dad said it would be OK.” Although it was none of my business, I said, “And, who is your Dad?” “Bill Hewlett.” Oh. OKaaayyy. I think it was son, Walter.

Employee benefits. Most of us have read of the many innovations that Bill and Dave instituted for their employees. In the early years, when one employee had a catastrophic medical episode, they realized that their company should provide for group medical benefits, long before American industry came to embrace such benefits.

But Bill was also observant about individual situations too. I was told about the early publications department, where Mary Hurt worked as a “repro-typist.” Later, she and the other graphics people transferred into my Marketing Group in the Microwave Division. It seems that Mary’s marriage was such that she was raising 3 or 4 kids all by herself, and this was causing serious time constraints on her being home to watch the kids and being at HP to do her graphics work. Bill found out about the situation, and told the managers to make whatever arrangements were necessary, so that Mary could work at home on her special company type-setter typewriter, until such time that the kids were old enough to help in the family’s responsibilities. Mary never forgot that exceptional act of humanity, and told us about it until she died decades later of cancer.

Open door policy. Dave and Bill were well known for introducing two management processes, *The HP Way and Management by Objective*. But they also promulgated another process that was even more important in some ways, it was called the *Open Door Policy*. This simply stated that when there was an important matter that your own management wouldn’t listen to or accept, you had a right to walk into any higher-level manager in the company to make your case. The door was open. Bill had a “feel” for what was right for common-sense management principles, so it wouldn’t surprise me if he was the source of this idea.

In actuality, both Dave and Bill recognized that such a permissive policy might be abused by an endless complainer. So they specified that the employee had to first exhaust their

appeals at the first and second level of management. This rather remarkable policy had two important effects; 1) It gave a sense of empowerment to each employee and made you feel like top management was with you, and 2) It proclaimed a not-so-subtle warning to mid-level managers that their actions were reviewable at the highest level.

Here is one specific example I am aware of. One of my friends had begun reporting to a new manager who had been hired in from Ampex Corporation, presumably for some of his tape recorder systems expertise. 1970 was not a good year for high-tech, HP fell into a bit of a recession, and the word came down from top management to trim 10% off operating costs.

My friend got called into his boss’s office and was told that he was fired. That was the Ampex way of controlling costs, hire and fire as the profits allowed. This kind of employee treatment was unheard of at HP. Luckily my friend didn’t take it lying down, but using HP’s “Open Door” policy, he marched up to Bldg 3U, and told Bill what had happened. Bill rescinded the firing order on the spot. The word got back quickly to the Ampex guy’s division manager, since it also appeared that my friend’s performance reviews might have been doctored to justify the layoff. I think HE might have been the one let go. Soon after, this memo was sent to all HP management:

From: Bill Hewlett July 16, 1970
To: See Distribution

SUBJECT: Evaluations & Terminations

An increasing number of cases are coming to my attention in which employees are being terminated with little or no warning that their performance has been unsatisfactory. In some cases, evaluations have been glowing up to the time that an individual is released.

There just is no excuse for this. It is not humane. It is not HP-like. It is not justified. I would like you to be guided by the four following points:

(1) The individual affected had had advance warning through written evaluations and has been advised constructively on how he/she should improve.
(2) Wherever practical, assure the employee is given an opportunity for other placement where he/she might make a greater contribution. Employee placement is a function of supervisors and Personnel and not a function of the employee to be turned loose to find his own job someplace in HP.

(3) If termination is the only alternative. Personnel must be fully advised and believe the case is satisfactorily documented, and the decision has the approval of the general manager concerned.

(4) Before any adverse action is taken, it should be well thought out. We must recognize that each of our people represents an individual with problems, families, etc.

Signed: Bill H.

The 9-day fortnight. That 1970's business recession was also the time that Bill came up with his famous plan to deal with lowered revenues and production overcapacity. It was what John Doyle termed the 9-day fortnight. Hewlett reasoned that the nation's business would turn up in a year or so, and that HP could not afford to lose creative people, skilled production staff, and loyal employees who weren't themselves responsible for the downturn in business.

Hewlett observed that, "Usually in business, it is the little guy on the line who takes it in the chin, while management and higher-ups stay at work. It is only right that everyone share in the pain, up and down the line." He insisted that all employees take off every other Friday without pay, and this action was widely praised, not just within our employee ranks but got national publicity as a way to deal with downturns.

It was interesting that this was the recession period when Dave Packard was off in the Pentagon as Deputy Secretary of Defense. Hewlett made this important decision on his own, in conjunction with Noel Eldred and Ralph Lee whom he had brought into a corporate office triumvirate. The employee loyalty that resulted from this common sense plan was wonderful to see. Many employees actually came in to work on those Fridays, even though the production lines were shut down. Sales forces, of course, maintained their full schedule since increasing sales was the main point to get back to full employment. Factory marketing ran with skeleton staffs. In about one year, sales picked up and we all went back to work.

Fortuitously, the HP-35 hand calculator was introduced in 1972, and with its huge profitability, it single-handedly pulled the company out of trouble more quickly than the basic business recovery.

Finally, it is almost never mentioned that Bill Hewlett, in spite of his love of the technical side of HP, took over as CEO and Chairman of HP in 1969, when Dave Packard was appointed to Deputy Secretary of Defense, at the Pentagon. Bill formed an executive committee, consisting of himself, Noel Eldred and Ralph Lee (Porter had died), and grew the company from \$326 to over \$479 million. This was an average of HP's usual 15% per year, for those 3.5 years, without the benefit of Dave's presence, and in the face of a persistent business recession.

Hewlett's HP120B Gift. This story came to me in 2009, when Ken Chalfant of Colorado Springs, CO, contacted Ken Kuhn in Birmingham, AL, to find if he might have a spare HP 120B scope bezel. Ken Kuhn's name comes up in this Narrative several times, because he is a big HP booster, and further, maintains a basement and garage full of more than 400 vintage HP instruments. And he never worked for HP. He passed along Chalfant's charming interaction with Bill Hewlett.

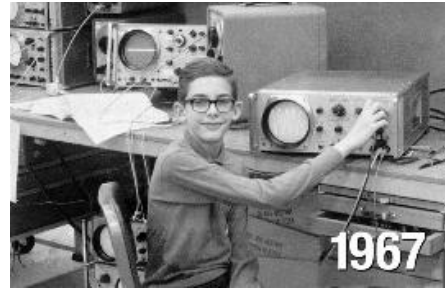

Chalfant reminisces: "My story regarding Hewlett Packard starts in 1967 when I was a junior high school student (age 13). I was already totally focused on electronics, owned an EICO VTVM and was trying to save up money to buy a kit form oscilloscope from HeathKit when my science class went on a tour of the local HP plant here in Colorado Springs, CO.

Wall to wall, as far as I could see was test equipment and oscilloscopes so far beyond fantastic that I probably almost had a seizure! When I got home I called out to the plant and asked if they had any used scopes for sale. "We don't sell our used equipment." came the answer. "How much is your least expensive scope in kit form?" I asked. "We put all our equipment together - we don't offer kit form." was the reply, followed by "Would you like a catalog?"

My mom took me out to the plant and I met the local marketing manager that I had talked to on the telephone and he gave me a copy of their catalog. OH MY! What a catalog! It was nearly an inch thick of glossy pages stitch hard-bound into a beautiful book. I took it everywhere and wore it out! It was not only filled with their equipment, but a great deal of information on how their equipment worked and how to apply it. That catalog was my first electronics instrumentation text book. I still have that exact copy and I have also bought a pristine copy for my library.

Well I wasn't finished - I was not ready to give up on getting an HP scope so I wrote Mr. Hewlett a letter and asked him if I could buy a used one. Well to keep a long story somewhat shorter - Mr. Hewlett gave me a 120B scope!

Forty years - to the month - later - Agilent rediscovered the story of what Mr. Hewlett had done for me and they invited me out to the Colorado factory as a guest speaker to talk about Mr. Hewlett and the "good old" HP days - even though I have never worked for HP. Then they did it again - they gave me another scope.

Its amazing that a man I never met and a company I never worked for have had such a profound and positive impact on my life! Mr. Hewlett, followed by several engineers at the Colorado Springs plant, helped me so much when I was just a kid! Then after telling "my" story and helping them remember how fantastic Mr. Hewlett and HP really were they basically "framed" my life by giving me another scope.



Of course, I'm completely biased, but I doubt there will ever be two more significant and honorable business people than Mr. Hewlett and Mr. Packard. I don't think anyone will ever build a company that will contribute as much in technical terms and so much more in human terms than did Mr. Hewlett and Mr. Packard. Agilent still makes fantastic equipment and there are many wonderful, caring, involved people working there, but Agilent is not - and never will be - Hewlett Packard."

Dave Packard

Dave was well-known for being the "business-oriented" partner, while Bill assumed the more technical role. With his 6-4 stature, and Stanford football player physique, he always dominated any meeting or gathering, whether a speech to the investment analysts on Wall Street, or while standing at the coffee pot. Most everyone is familiar with his management style, as described in his book, *The HP Way*. I wanted to mention several specific interactions I had with him, personally, and which will help you understand the humanity of the man.

Chinese engineers. After President Richard Nixon "opened up" the People's Republic of China, Bill Hewlett and Dave Packard both visited China in the several years thereafter. During Packard's visit, he met with the Fourth Minister of Machine Building, which was similar to the Russian organizational hierarchy. The Fourth Minister was the national official responsible for all electronic and communications activities in their country.

The technology situation in the PRC was serious, because the previous "Cultural Revolution," permitted by Chairman Mao, had decimated their academic and technical community. It had resulted in 2-3 million deaths in the purge of intellectuals. By the time Packard visited, the country was trying desperately to rebuild their technical infrastructure, a monumental effort. As a result, Packard agreed to host 20 young engineers at HP for one year, to have them work alongside our production people, to gain a knowledge of current state-of-the-art electronics production. Dave's objective was clearly to plant our HP flag in China for future business opportunities.

Packard called V.P. Bill Terry, to tell him to arrange things. Bill appointed me as the Test & Measurement Organization host, to be ready to host 8 of the 20 engineers. So I set up the planning for those engineers to go through some initial measurements training, and then prepared the one-year "dance card" with schedules of each engineer for their year here. This plan would take them through the many different production

functions, printed circuit production, production control, fabrication, etc, for a full year.

Since I had been given virtually zero detail, I called Dave to ask if I could come over and review the plan. In his office, after he had taken a few minutes to read the summary, I asked if it looked all right to him, based on his understanding with the Fourth Minister? He looked at me, with a sheepish smile and said, "You know, John, the night I arranged this plan with the Fourth Minister, we were at a long ceremonial dinner, and frankly, we had had quite a few toasts, and a lot to drink. So the specific issues of the engineer visitors are not real clear to me today. However, this looks like a fine plan. Go with it." To me, this confirmed the total honesty of the man.

A funny incident happened when the Chinese engineers arrived about a year later. Our first formal process was a 12-week measurement training course, to acquaint them with HP's products and services. Actually it was the same measurement training course which was given to all new HP field sales engineers. It was about Christmas time, and the training was taking place in Bldg 18, at the corner of Page Mill Rd and Foothill Expressway, in a building shared with the HP TV studio.

Since the Chinese group was about 20, we set up a special class for them alone. I was observing the training orientation, when suddenly I was called out of the room, to face several U.S. Secret Service agents. It seems that U.S. Secretary of State, George Schultz, who had his home on the Stanford University grounds, was home for the holidays. He decided that morning to visit his son, who happened to work at the HP TV studio in the same building. When the Secret Service heard, during their quiet visit, that there were "Red Communist" Chinese personnel on the same site, I guess they really spooked out.

They had gone into a protective mode for Schultz, then told me that everyone in the room would have to remain there for an hour. I had the temerity to ask if we could first offer the students the chance to go to the bathroom, and they relented. But I could never tell those students just what happened.

I was profoundly impressed with those young Chinese engineers. Since they had been selected by a nationwide process, they were given the travelling status of "Diplomat." This was not a trivial distinction, since their ordinary in-country monthly wage was \$30 U.S. HP had agreed to pay them a salary of \$1500 per month, which was our going rate for new-hire engineers, and under their country's diplomat provision, they were permitted to keep it all. We organized a housing program, whereby they lived, two to a room, at the Flamingo Motel, on El Camino, where our visiting FEs normally stayed. We also bought them all bicycles to get to work on the hill.

Imagine my surprise, a month later, when I visited their motel, and found out that most of them had moved out, and found other less-expensive apartments, and now were living 6 to an apartment. They were serious about saving money. But it is what they did with the saved money that impressed me.

Since most of them had been voted in by their local factory

personnel council, they felt a true obligation to their factory. For example, as they learned about our HP environment testing program, they began to request for me to order them temperature testing equipment and systems, from various sales catalogs. By that time, HP's pre-production testing had revealed that every product, ready for production, would get a full series of high temperature tests. To assure that their factories would have the latest in test procedures, they bought the same temperature-logging gear HP used.

They also bought numerous TV sets, calculators and personal computers, all of which were going to go back, to be shared with the people in their factories. On one occasion, I used an HP truck to carry all their boxes to the Port of Oakland, to load into a transport container. I think there were 150 boxes, all of which had to have customs documentation, and shipping arrangements. Our shipping people were of great assistance, in guiding them on the least expensive mode.

The specific State Department program authorization we worked under was unusual. The project fell under the U.S. Technology Transfer laws, with some REALLY serious penalties hanging over any mistakes. The paperwork we furnished to get approval for the year-long program, also was interesting. These alien engineers were allowed to work anywhere in our shops, read any documentation, actually order instruction manuals for HP equipment, and other printed industrial materials, commercially available. But the one thing they could NOT do, was to talk personally with any of our R&D engineers. It seemed a quaint rule, regarding the nation's technology transfer restrictions. Further, we had an intensive briefing with the FBI, so that we knew exactly what to do in case any one engineer asked for political asylum. Not one of the 20 ever did.

As it developed, it was a very successful program, and in later years, I heard from more than one of our HP sales people in China, that several of the early trainees had asked about me, and were ordering HP products. I believe that several actually came to work for HP China in later years, and certainly they all became good HP equipment customers.

George Stanley was closely involved in the HP entry back into the People's Republic of China, and relates his remembrances: "Bob Brunner always like to travel to unusual places. So right after Nixon opened up China, Bob was about the first person to figure a way to go there. While in China, he looked up an old college classmate, who was fairly high up in the Chinese government and asked him, "How would China like to have a team of HP engineers come to China and teach you the latest in western measurement techniques."

"The Chinese manager jumped at the chance. Bob had cleared this with H and P and Doolittle before he left. When Bob came back he asked me to put together the technical program. Lee Ting handled the political/business coordination, and the team consisted of Art Fong, Dave Widman, two guys from Ft. Collins, and Bob Frankenberg from the computer side. I think there were a few others."

"I had Don Hawke organize and ship all the equipment. We worked closely with the U.S. State Department. We were in China for four weeks in June of 1979. The first week was

used to unpack the equipment, set up and work with our translators. A month before leaving the U.S. we had to send the complete text of our technical talks. I had HP-IB for four days, but remember this is two days of material because of the translations."

"All in all there were probably about 150 Chinese who attended. my class was led by a Red Guard radical who marched his class in, told them to sit, told me to start, and would stop me periodically and say, 'we take break now.' He would march the class out and back, etc"

"We found out that we could take our wives if we paid the air fare. The hotel costs were the same for two as for one so all brought their wives and that sets up a story. The Chinese set up daily tours for the wives with special guides...no charge. The reason was because the guides were all top Chinese Government translators who wanted to polish up their English. One day my wife was asked, "what does, 'in the same ballpark mean?'"

"We were in the Machine Pak building over near the Zoo, but stayed in the Grand Hotel near the Forbidden City. Engineers came from all over China by train and for some it was a two-day trip. Only one came by plane, and he was a EE Prof. from SW China. I got to know him fairly well as later he came to the U.S. on a trip."

"We always had handlers and were escorted everywhere even after the formal session ended. We were allowed to visit other cities in China, but we would be taken to the plane and then met at the next stop. We worked our way south, eventually exiting into Hong Kong."

"Brunner told me my second objective was to get the name/address of every engineer who attended so we could put them on the HP Journal mailing list. I did. There were many interesting events. One was the whole country was studying English. There were two radio programs: The Chinese ran one and the Voice of America ran the other one. Being white, we stood out so we were often approached to correct their English homework."

"The EE Prof once told me people used to study Russian but everyone had given that up and were now all doing English. The VOA broadcast in 'Special English', which was a printed list of about 500 words that were spoken extra slowly. I tried to get the list of Special English words to give to the Divisions to use when giving seminars abroad, but VOA told me I would have to have someone outside the U.S. order it. I didn't follow up."

"John Young managed to show up at the very end as he came over from a meeting in Malaysia. There were nightly dinners with the Chinese and they always tried to get us drunk with their clear fire-water. Somehow we all survived even though we had to rewire the Machine Pak Building to get enough power to run our equipment."

"As a result of our visit the Chinese published the HP-IB info and a test I used in a technical journal. This was in Chinese and I used it (in Chinese) when I gave the Chinese engineers of the Packard invitation their final exam. I think they were

surprised that part of their exam was in Chinese. All this led to a Chinese invitation to H and P to visit China and you know the rest.”

By the way, Packard resigned from his Pentagon job well before the Watergate political scandal broke under Nixon. In a real ironic twist of fate, Packard and his wife lived at the Watergate complex during his tour at the Pentagon. One wonders if he somehow had found out about the bad things going on across the Potomac? It was also at approximately that time, that John Young began his long rise to fame, and moved up to Electronic Group V.P., from his leadership of the Microwave Division.

“We’ll find someone who can.” At one of the 1960's management reviews at Rickey's Hyatt House in Palo Alto, it had been a long day of presentations. I happened upon Dave, standing at the bar, for the usual after-meeting libation. He would usually ask how one's work was going, as a sort of generic comment.

As it happened, about two days before, I had had to tell a long-term microwave application engineer, who reported to me, that his work was not adequate. This was even after we had informed him of the inadequacy and worked with him for a full year to solve his problem. I mentioned to Dave that the act of actually telling an employee, that he would have to leave HP, was one of the hardest things I had ever had to do.

Now, all of us employees had an overall impression of Dave Packard as a "tough-minded" manager, because we had all heard of his statement, "If you can't do the job, we'll find someone who can." So I figured with my story, he would probably understand my personal distress. He surprised me with his response, "Well, John, it may interest you to know that I have only personally fired 2 employees in my time. And those events were two of the hardest things I have done, too." That comment only increased my admiration for the human Dave Packard. I inferred afterward, that he probably just told others to tell people they had to go.

Viet Nam. In 1969, Packard was recruited by Melvin Laird, who was the political transition manager, tasked to find high level appointees to the Nixon administration. Laird himself was appointed to be Secretary of Defense. Packard agreed to become Deputy Secretary of Defense, as long as Mr. Laird agreed to be the “Mr. Outside, who would deal with Congress and the public. Dave would be “Mr. Inside,” and would deal with operations and procurement. As he told his employees, he had always felt that he owed his country some national service time, because he stayed and managed HP on the home front during WWII, while Bill served in the U.S. Army Signal Corps.

During the years Dave was running the inside operations of the Pentagon, we would often have military visitors who were coming to HP for contract negotiations. They told impressive stories of Dave’s pragmatism, in managing a huge agency and huge procurement budget amounts. Packard was responsible for the Pentagon’s “Fly before Buy” contracting concept, which he introduced to avoid the excessive budget overruns. These were caused in previous administrations, by going into production before a weapons system had all the operational

and technical kinks worked out.

In the late 1970’s, one of our newly-recruited field engineers (Jim) told me of an interaction he had had with Dave Packard in Vietnam. He was a young fighter pilot, and USAF Captain, during an inspection trip Packard was making to the military bases there. Packard had specifically asked the military commander to bring about 25 of the pilots who were carrying out the missions into a conference room. So Jim and the others were there in the conference room, sitting at attention, while around the walls were several dozen higher-ranking brass.

As Packard came in, he noticed the large array of colonels and other high ranks, and asked, “I thought I was quite specific, that I only wanted to talk with the men doing the flying.” One ranking officer noted that they felt that it was important for them to attend, because then they would know what issues to take seriously. Dave reiterated that he was serious in his request, and that all of them should leave, which they did, a little humiliated in front of their troops.

Dave then took off his suit coat, rolled up his long-sleeved white shirt, and draped himself on a chair. He proceeded to spend about 2 hours in the meeting, getting to understand the true tactical situation. It was the HP “open door” policy, sort of in reverse. Jim decided that day, that if he survived, he would do all he could to work for HP in the future, and later he did join the HP field sales force.

Packard in Washington. Dick Rucker recalls that he and his wife Claudia ran into Packard one early Sunday morning at the National Zoo in Washington. Dave was scheduled to appear before a Congressional hearing on his upcoming Pentagon appointment on Monday, and he was there, “apparently, just to relax and gather his thoughts.”

“We ran into him in the large bird aviary -- it is a large screened-in area but otherwise open to the elements, and it was home to a California condor, a couple of American Eagles, and a few other large birds. He was standing there, with his hands in his pockets, looking up, admiring one of them.”

“I walked over and introduced Claudia and myself, and told him we were both former HP employees who had met and married while there. He chatted with us for a few minutes, then we wished him well, and left him alone with his thoughts.”

“My particular memory is of him standing there, looking up, just as I realized who this tall, very distinguished man, was. It was a gray day, with only the three of us in the aviary, along with those big birds, very quiet and peaceful.”

Moving garages. After Bldg 20 was built on the Hanover/ Page Mill Rd. site, and before the Addison garage was pronounced a California Historical Site, I wrote a short proposal to Dave, to combine some historic buildings. I proposed that HP move the first Addison garage, plus the second garage home of HP, behind the “Tinkerbell” Polly and Jake’s Antique Store at El Camino and Page Mill Rd, plus the old Quonset Hut, WWII building at Page Mill and Birch, all

over to the back lot of the Bldg 20 site.

My thought was that one of those buildings could serve as an archive and museum, for visitors to HP headquarters for decades to come. Packard called me over and told me that it was an interesting proposal, and that he would not oppose it if I wished to raise money to do it. But he said that he was totally uninterested in preserving all those old things.

I abandoned the effort, although I think I could have found enough money among some of Dave's contemporary middle managers, who had become fairly wealthy on HP stock options. I knew that some of them were more nostalgic about those buildings, since many of them had worked in them.

The Aquarium. Sometime after the Monterey Bay Aquarium was finished, using funding from the Dave and Lucile Packard Foundation, I happened to be sitting across from Dave, at some sort of company management affair dinner. It was an informal event as most were. The aquarium project had been reported to have run \$10 million over the original \$35 million budget, and I couldn't resist tweaking Dave about it. He was always pretty hard on us, if our company projects couldn't stay within budget.

He smiled and actually looked a little embarrassed, if that was possible. He said, "Well, you know, John, we actually expected to run over, because we knew we were attempting things there that had never been done before." He mentioned the wave machine operation, the huge fiberglass mammal figures on the ceiling, and the serious technical considerations over those huge tanks and acrylic windows.

We all loved that man for his humanity, and much of it is preserved in that great aquarium institution, funded by Lucile and Dave, although almost none of the visitors ever knew him as a person. I have noticed as I walk through the aquarium, that his daughter, Julie, has done a superior job, enlisting hundreds of other contributors, in the years since, and carrying on that grand training site. Almost every day, it is filled with hundreds of kids and ordinary people, learning about our great oceans and the preservation of natural things. Dave had established an alternate home there in Monterey during those years of construction of the aquarium, and after it started in a hugely successful operation. It must have given him and Lucile great pleasure to see how ordinary people enjoyed that impressive facility of ocean science, and unique teaching resource.

Marketing interns. Packard was known for only a few impetuous actions. On one occasion, when he was Chairman of the Board of Trustees of Stanford, he decided to take on two Stanford interns, one each summer. Both were "thought leaders," and editors of the *Stanford Daily* newspaper. He had them report to John Young, and in turn, to me in the marketing department. Their names were Kirk Hanson and Phil Taubman. They were bright and energetic young MBAs, and I set up some summer projects for them to evaluate a number of different processes in our marketing department. I also had one of them do a survey of work attitudes of my department in some detail. This was the first time I recall, that we used summer interns.

I found it interesting to follow the careers of those young men. Kirk Hanson came back to teach at the Stanford Business School after graduate work at Harvard Divinity, and for several decades taught business ethics. He recently moved to Santa Clara University, to run a new ethics department. He has considerable work going on now, what with the Enron scandal, and the serious condition of U.S. corporate governance. Phil Taubman went to Time Magazine, and became a senior editor, with a number of journalism awards to his credit. In a later interview, Hanson gave great credit to our summer employment job.

Another intern HP took on, after Packard returned from the Pentagon, was a young U.S. career service manager at a GS14 level, about mid-management in government ranking. Packard's plan was to have fledgling government managers spend 3-4 months at HP, learning the private sector methods and process measures, and bring them back to the Pentagon. I don't remember his name, from his project work at SPD, but I did remember his voice.

About a year later, I was on a business trip to Washington for other reasons, and on a spare afternoon, called Bill, an old USAF navigation school classmate of mine, who was assigned at the Pentagon. Bill was a Bird (full) Colonel, on the 5th (USAF) floor. For reference, in my navigation cadet days in Texas, a Bird Colonel ran the entire base of 5000 men, but at the Pentagon, Bird Colonels were a dime a dozen. Bill was in a crowded office of about ten, 1-star Generals. If you were a 1-star, you got a desk and a filing cabinet AND table. Colonels didn't get the table. Anyway, as we were talking, I heard a familiar voice at their Xerox machine, and amazingly, it was the Packard intern I had met at HP. He just happened to come down the hall, because his own department's Xerox was broken down that day. Imagine that coincidence in a Pentagon with 25,000 employees!

Loyalty to old friends. Another occasion I am familiar with, was when Art Fong's wife, Mary, came down with a brain tumor, which required a serious operation. The operation was successful, but her rehab was long and frustrating. After she got back on her feet, it was either Dave or Bill who was talking to Art about Mary's recovery, and told Art to take Mary on a round-the-world trip, at company time and expense, to reward him for exceptional creativity. At one time, we, in Microwave Marketing had added up the estimated revenues of all the popular instrument projects that Art had managed. It came out to more than \$200 million dollars. I think our calculation was made in 1980. This included the HP 8551A, 606A, 618A, 623A, 803A/417A, 614A and many others. An unusually-productive career.

Noel Porter

In the late 1950's, Noel, the son of a Palo Alto minister, was the HP manufacturing manager. He was also the two-term mayor of Palo Alto, all at the same time. In his own way, he was a genius in being able to juggle these difficult jobs together. He would spend the mornings at HP, running the plant. He went to city hall for the afternoons. Evenings, he would return to the plant, reading memos, and typing small 3 x 5 "Portergrams" to everyone that needed jogging, using his two-finger typing method.

Noel Porter was a very popular figure on the production lines. Probably more than anyone else, he practiced what was to become "management by wandering around," later termed MBWA, in Business School case studies. The term was probably coined by John Doyle, the first Manufacturing Manager of the Microwave Division, and before it was recognized as a highly-useful management technique. Certainly Porter was popular with the assembly force, and all knew him personally.

My personal interactions with Porter were minimal. But in the 60's my family began an annual summer vacation ritual with a week at Meek's Bay Resort on the west shore of Lake Tahoe. It seems that the Porter family had owned a shore-side home up near Tahoe City for several generations, and opened the estate to the HP sailing club for a couple days of regatta, about that time in the summer. Although we weren't sailors, our family was invited up to enjoy the day on shore, with the generous and warm welcome of Noel and his wife.

Barney Oliver

My very first contact with Barney was described earlier in my HP job interview. Barney was an intellect in the genius range, with a purported IQ of 180. He was a classmate of Dave and Bill at Stanford, got his MS and PhD at Cal Tech and then went to work at the highest-prestige research lab of the world, Bell Telephone Labs (BTL) at Murray Hill, NJ. His work in WWII involved radar and other sophisticated system design, where his intellect made many technology contributions. Barney coined the word, "chirp radar," for its characteristics of a sweeping frequency, during the on pulse, which, in audio terms, would logically have sounded like a chirp.

Later, in 1959, when I used to make some sales calls at BTL with Bob MacVeety, our New Jersey Rep, I asked some senior engineers about their remembrances of Barney. It turns out that there were three certified geniuses at BTL at the same time, Claude Shannon of information theory fame, John Pierce, of communication satellite and traveling wave amplifier fame, and Barney. Apparently the three of those people were intellectually INSUFFERABLE. They were so bright and capable, and they cut an intellectual swath through that engineering community, that only a prestige lab like BTL could handle all three at once. I read about April 1, 2002, that John Pierce had just died at Stanford.

Barney was notorious for stress technical interviews with new lab candidates. I just got a small taste of that, before he turned me over to marketing. But it also carried over to his other activities too. He did not suffer fools lightly. In one conference room forum, one engineer's question from the floor, was answered with, "That was a stupid question! Next question." Needless to say even his own people were cautious around him.

Eclectic interests. Barney was a man with eclectic interests. His interests in the search for other intelligent life in the universe is well known. He was an early supporter for SETI, the impressive and sophisticated listening system, headquartered at the NASA research headquarters in Mountain View, CA, and with huge desert antenna farms in

southern California. Barney had an interesting theory about other intelligent beings. He postulated that a planetary civilization might grow from an evolutionary process much like our own, leading to superior beings and equipment on some other planet.

He had actually worked out the probabilities of how many thousands of earth-like bodies, there might be in the cosmos, that were capable of supporting life. But he also felt that most such highly technical civilizations would die out within a thousand years or so. This led to the conclusion, that if there were some such intelligent civilizations, trying to communicate or transmit signals, if it took a million years to develop and die, that the probability that any two such would exist at just the same time they could transmit or receive, would be very low. Yet, the probability was not zero, and thus the Project SETI made some technology sense.

Barney also had a conservation side. I recall a monograph he wrote, about conservation of resources. He pointed out that of all the material goods we consume, we do an absolutely terrible job of recycling. He noted that atoms don't wear out, they just get misplaced. We start with a high grade ore in a mountain of iron ore, refine it, fabricate it, use it, and throw it into a dump ground where it is mixed up and lost to future generations.

I also recall an interesting observation he made, when laser technology was first invented. At the time, AT&T was postulating that they could build a 2-foot diameter pipe, which would stretch across the country, and be evacuated to a vacuum. By using large lenses periodically, they could re-collimate the laser light over the continental distance. Then, modulating with high speed digital data, they could replace their cross-country TH-microwave communications backbone, and their underground cable multiplex L-systems. Barney calculated that if you took laser light, and modulated it to only 1% bandwidth, you could modulate on one beam, all the conversations of the world. At that time, the world population was 4 billion people, but he then corrected himself to note that it was really 2 billion conversations, because half the world's people would be at each end.

In his later years, Barney helped found or served as technical advisor for a number of companies. One of these, was a company which grew and sold nematodes. He took great joy, in explaining that there were 500,000 species of nematodes in the world, and if you could find the right ones, and grew them, they would do wonderful things. His company, for example, found a certain strain, which ate corn-borers, the nasty little bug which could destroy a whole corn field by weakening the roots, after which the stalks fell down. His nematodes would multiply by eating the corn borer, and then when that food supply dried up, the nematodes also would die. A perfect silver-bullet pest-fighter, which was not toxic. He also noted that this was the only product he knew of, where the supplier furnished a microscope with each shipment, because the product was so tiny, you couldn't see it with the naked eye.

I happened to be in his group at the cafeteria lunch one day, with several of his top scientists from HP Labs. The sunspot cycle was just peaking, and one result was the disruption of

the communications systems, due to the earth's ionospheric layer getting demolished by particles from the sun. One of the other serious effects, which almost no one knew about, was the vulnerability of the nation's electric power grid, to these same infusions of particles. The electric power grid of the U.S. is a delicately balanced and interconnected system, which allows power to flow from places of excess, like Oregon's Bonneville Dam, to California. It also supplies power in cases of emergency shutdown of major local generation facilities.

But the interconnection itself is also the key to making the system unstable. With high tension lines thousands of miles long, their characteristic of catching the effects of the sun's particles, makes the system unstable. As Barney and the others discussed the solution, which had already been the subject of many industry research projects, it was noted that with these power levels, one couldn't just "ground" things like in the lab, with a grounding strap. Barney suddenly proclaimed that some sort of rotating machine, which normally acted as a electric generator, could be modified to act as a floating ground, and the others agreed. I, of course, was way over my head, as usual in discussions with Barney.

Along in his career, Barney ran for the Palo Alto Unified School Board, and won a seat, and soon was Chairman. I don't recall if he was urged to get in some community service, perhaps by Mayor Noel Porter, or later when Packard had served his several terms as Chairman of the School Board.

Dealing with the public was probably not his finest hour, either. And Palo Alto, being a city with a major content of eggheads, college grads, included a high percentage of Stanford grads who didn't want to move away from the womb, etc (like me, I admit.). So he took some hard knocks in his early years on the board, but slowly the rough edges were rounded off, and he became a well-liked public servant.

The BART Technical Commission. Barney's technical expertise was well known to the high-tech community. When the Bay Area Rapid Transit (BART) system started construction in 1964, in one of their early rolling tests, one of the test trains approached the Fremont, end-of-the-line, station. Instead of slowing down, the train plowed into a pile of sand that some cautious engineer had insisted on providing instead of a hard bumper. Luckily the train was only traveling at about 25 mph, with no passengers.

One of our HP corporate managers, Jack Beckett, had been involved in industrial volunteering for some years, and at the time was Chairman of the Metropolitan Transit Commission for the Bay Area. Their responsibilities included oversight responsibility for BART, and such a serious operating computer failure was potentially catastrophic. It was crucial that the deficiency of the train control system be immediately investigated, so that the rollout of the system could proceed without concern about defective control.

The design for the BART was visionary, with the committee focusing on high tech cars and control technology. In retrospect, it was probably not a good decision, and the

committee would have done well to visit Europe where they had for decades built and operated rugged and reliable cars and control systems that were designed for fail-safe performance. Westinghouse was the main contractor chosen for their futuristic control proposal. But there were to be revealed a number of black-holes in their design.

Beckett immediately got his Board to appoint a technical study commission, chaired by Barney. What they found was troubling. The objective of the original proposal was to have a system of trains running at up to 90 mph with a 3-5 minute headway (4.5-7.5 miles) between them---without human operators. Geez, there is a design just begging for fatalities. The train control consisted of a radio link between the speeding train and an endless antenna running alongside the tracks. The braking system of every train was controlled by an automated built-in stopping profile determined by the wayside electronic signaling system based on the distance ahead of another train. This "local" train control was augmented by the central computer system (big-daddy) in Oakland.

Dave Cochran later filled me in on some of the project details. On the day of the "crash," the car detected its approach to Fremont station, and sent its signal to the speed control system in the train to call for the beginning of brake action. However the 27 mph crystal had shorted and the speed control system went to a free running oscillator that happened to call for 70 mph. The system had not been designed "fail-safe," i.e. to stop if the correct speed could not be attained. The on-board human operator operated the emergency brake, but the few-second hesitation was enough for the train to over-run the station.

The upshot of that revelation resulted in a scathing letter that Barney wrote to the CEO of Westinghouse. In essence, Barney accused the company of dereliction of engineering responsibility and suggested that they must have assigned their poorest engineers to the tasks. Redesign took place immediately. I believe that was the year that Barney had been elected to the presidency of the IEEE, the international society of professional engineers. So his words had extra impact on Westinghouse.

Another system design flaw was discovered in a "phantom" train problem. It seems that Westinghouse did not use the decades-old design practice of train detection, as practiced in Europe. Instead because of the continuous welded rail to eliminate the clickity-clack, they had to design a monitor which measures the electrical impedance between the two rails by the steel wheels of the car touching both rails. The problem is that Westinghouse didn't count on the nasty environment of the rails, oil, dirt, corrosion and water that meant that the impedance changes weren't sensed correctly.

The urgency of a fix was paramount, since the system was close to coming on line. The upshot to the Oliver study was to quickly design an alternate system to ensure continuous detection. In the interim, human operators at each station would provide input (they would call the up-line station and tell them to release the train) so that the main system operating displays were assured. For a time, a given train could not get a command to leave a given station if an

operator at an advanced station had not given proof that the previous train had left a future station.

Out of the Oliver commission came a "Logic Back-up Train Detection System" based on the fact that trains cannot appear or disappear from the track. A simple wayside logic system with each block (minimum detectable length) contains the presence of a train once detected. It cannot be dropped until detection is registered in the successive block. The wayside system daisy chains this all together. If movement of the train is not detected in the next block, the stopping profile remains behind in the original block.

This concept was designed by Len Cutler and Dave Cochran solicited by Barney for his commission, a patent was received for the idea with BART granted a royalty free license.

The final upshot of the Oliver Commission was that BART service came up on time, ran for some years with the duplicate control systems and human operators giving individual approval for a train to leave particular stations based on a prior train being seen leaving a station further along, making the tracks clear. During that period, major redesign took place in the entire system control computers, sensors, with the "Logic Back-up System" integrated in a fail safe manner into the central computers. Now, 30 years later, the BART operation has been remarkably free of dangerous crashes and failures, never has one train hit another.

Mount Uminum? When Barney's R&D lab was located in Bldg 1U, newly-hired lab engineers would often find some unexpected results on their oscilloscope displays when probing their circuit waveforms. It was sort of a ritual of passage, because their senior engineer associates would usually keep quiet about the effect.

If all the conditions were right, what the engineers would see was that their expected waveforms would be OK, but every so often the circuit would go wild with large repetitive pulses ruining what they thought was their prize stable circuit. It wouldn't happen regularly, and the period of occurrence was about every 9 seconds. But a circuit that runs wild is not an acceptable one, and the phenomenon would sometimes drive the poor engineer crazy trying to figure what was going wrong. About that time, the seniors would charitably explain what was happening.

The south-looking glass windows of Bldg 1 faced almost directly south to Mount Uminum, 25 miles away. A very long-range USAF sea-search radar was located on the top of the mountain, and its antenna rotation period was just 9 seconds. When the location of probing wires and the circuit was just right, the high power radar pulses could be acquired by the loops of wires, and presented on the scope display. Even though the frequency of the microwave signal was well above the video scope display, the radar signal was strong enough to overload the front end, high sensitivity amplifier and would self-detect to provide a video-like pulse.

It had another effect as well. When Barney had come back from Bell Labs to HP, he brought with him a profound affinity for high quality audio. In those years, HP used a plant-wide paging system, with speakers in all buildings.

Although it was good quality audio, it was not up to the standards of Barney's quality ear. So he undertook to re-design the power amplifiers with exceedingly low distortion and hum and all those bad audio signal things.

The paging telephone operators were located in their switchboard room at the inner corner of Bldg 1 and 3. They, too, were exposed to the Mount Uminum radar illumination signals, and you guessed it. Sometime after the new audio amplifiers were installed, again when all the conditions were right, one of the operators voice cables served as an antenna, and fed the repetitive pulses into the audio amplifier. In this case, when the system was keyed, a loud buuuurrrrrpppp sound occurred. Each time that operator keyed for a page, it burped.

Barney called out a couple of his engineer crew with audio credentials to look for the problem, because it sounded like an uncommon defect in audio amplifiers, called motorboating. Could Barney's magnificent amplifier be a victim of that serious defect? You can also imagine that looking for this intermittent effect was pretty discouraging for a time, but they soon figured it out. And with a few simple input circuit modifications, any voice cable position was soon insensitive to the effect.

Ralph Lee

Ralph Lee treated the spending of HP's money like his very own. A manufacturing manager in the mid-1960's, he was known for his frugal control of budgets, yet creative manufacturing skills. Later, as he became Group Manager and Executive VP, he became better known as the office partition fighter. As HP's divisions moved to outlying cities, the traditional HP "bull-pen" style of large, open bays of desks and engineer benches would give way to wall partitions, as the local management moved to be more like other companies. More than once, on a Ralph Lee visit, he would call in the local facilities people, and order them to begin dismantling the offending partitions and private offices on the spot. Word got around.

Yet, Ralph's parsimony was itself balanced off on occasion. At a Monterey Management Conference I attended, Ralph used part of his manufacturing overview to present a slide showing that inventory control of hand tools was failing. He put up a slide, which showed that HP had purchased about twice as many sets of hand tools, as we had hired new technical people, and that it amounted to maybe \$60,000 per year.

Bill Hewlett was sitting in the front row, and suddenly stopped the presentation with the question, "Hold it right there, Ralph. What's your point?" Ralph then pointed out that it looked as if many of the newly-hired engineers were stocking up their home workbench.

Bill's reply was certain to be remembered by all managers present. "Look," he said, "our R&D strategy is to hire mostly young engineers, right out of college. For many of them, this is their first big-time job. We look for those types of young people who are busy with other technical hobbies, beyond work, like ham radio, fixing their cars, audio and sound

system aficionados. We'd like them to learn which end of a soldering iron to pick up. If that means that we have to buy two sets of tools for every new hire, that's the right thing to do. And they should have access to reasonable parts from the lab stock too."

Another common-sense rule, which made our HP engineers feel like they were appreciated.

Bruce Wholey

Part of the reason for HP's specific attention to microwave research was undoubtedly the fact that Bill Hewlett had recruited several engineers from WWII research facilities on the East Coast. Bruce Wholey, who later advanced to Microwave Division Manager in 1962, came from Fred Terman's Radio Research Lab (countermeasures), at Harvard University. R&D engineer Art Fong came from the MIT Radiation Lab (radar research). And there were a number of others with experience in microwave instrumentation.

Bruce was a roughhewn-appearing and gruff-sounding Canadian-born man. He would answer the phone with a gruff, "Halllowww." He sounded like you were the last person he wanted to hear from. But he was really a pussycat, and quite a warm manager. His main failing, if you were to ask most of his engineers, was that he would come over to their lab benches to chat, and then smoke almost continuously. Worse, he would drop the expended cigarettes on the tile floor underfoot, and stamp them out with his shoe, so the engineer's area would smell for the rest of the day.

When HP first bought Sanborn Corporation, it seemed like a pure cash-flow machine. Although its main business was medical electrocardiographs, the product line also included multi-channel pen recorders, which were in great demand during the aerospace race in the Cold War. Those multi-channel recorders were used for the large test systems for printing out mechanical vibration performance on things like airframes. The line was being sold by the Independent Reps that HP was already using. In many cases, the same Reps already handled both Sanborn and HP, so the fit was automatic.

But, I have always felt that Bill Hewlett was out looking for medical instrumentation for HP, since his father was a doctor. In a real sense, measurement technology, applied to medical science, was exciting and productive, and offered contributions to the human endeavor. I think Bill saw that as a place where our technology-driven company could make some real humanitarian contributions.

The medical electrocardiograph business was like the razor-razorblade business. Sanborn's product was top-of-the-line, because their design used a recording paper called Perma-paper. It was a paper sandwich with a black background, covered by a clean white wax coat. The black only showed through, when a heated stylus, on the end of the recording pen moved across the surface and melted the wax, revealing a stark black line on white. In doctor's offices, any sort of liquid ink process, that caused splattered dots and blotches, was not acceptable. The Sanborn paper was exceedingly clean, so the record could be stapled into the patient's medical

file folder.

Sanborn's problem was that their business model looked at the 60,000 U.S. primary care doctors as a cash-flow machine. They more or less gave away the cardiograph machine, in order to sell the high-profit paper. But the crucial fact, that somehow the HP acquisition managers failed to grasp, was that the 17-year patent for that special paper was about to expire. When that happened, shortly after HP became the new owner, the sub-contract paper manufacturer, Nashua Paper Products, started selling the paper directly to the doctors at a big discount. And a huge amount of revenue disappeared.

HP kept corporate management hands off for a year or two, but then Packard called on Bruce to move out to manage the recovery. Part of that recovery strategy was to inject more of HP's high-tech computer and system skills, and to begin to de-emphasize the individual doctor customer. This led to HP's move into intensive care system monitors. By exploiting HP's sensor technology and new computer system capabilities, the large systems found a much better fit to the HP field sales organizations. They just weren't equipped to answer phone calls from doctor's offices, on a weekend, to deliver a few dollars worth of Perma-paper. Furthermore, some revolutionary medical instrumentation breakthroughs resulted for HP as well, by emphasizing the large sophisticated intensive care monitoring.

Lyle Jevons

Lyle passed away on Easter Sunday, 1988. Although retired from HP since the mid 1970's, many of the people from the old Microwave Division remember him well, as well as his true impact on HP. In his early career, Lyle worked on instrumentation for the oil well industry in the Bakersfield, CA area. He later worked on the MA-1 fire control radar, at Hughes Aircraft Company, when owner Howard Hughes was still out in public.

Lyle told of nights, when they were on the Hughes Company flight line, after midnight, readying a fighter for a test mission to the California desert gunnery ranges the next day. The Hughes airstrip is still in Los Angeles, just about 3 miles north of LAX, and with a runway running parallel to LAX. Some nights, as they worked, a well-maintained DC-3, with a large bay window on one side, would land, and taxi over to the project workers. Pilot Howard Hughes, in old sun-tan pants would get out, roll up his sleeves and work along with the engineers.

Lyle gained most of his HP fame during the introduction of the HP 851A Microwave Spectrum Analyzer, in 1964. This was a brand new product sector for HP, with the main competitor being Polarad Corporation (not the film-maker, Polaroid) of Long Island, NY. Their business was about \$5 million, out of a total market of about \$8 million. They sold their instruments for about \$5,000 while Panoramic, Inc., also of Long Island, came in about \$7,000. Little foreign competition existed.

Lyle was working as Microwave Application Engineer at the time, and correctly predicted that the HP field engineers would not be able to come up to speed quickly, on

applications and measurement techniques for this brand new technology. He proposed for HP to buy him a Ford Econoline van, equip it to mount the HP 8551A in a rack at the rear doors, for easy access or removal, add an Onan AC power generator, and to take the show on the road. While not intuitive at the beginning, it was an enormous success.

Lyle spent probably 6 months on the road, slowly moving across the country, working with customers, always in the company of the local FE, and thereby teaching each one those new applications at the same time he was selling to the customers. We began to see orders arriving from customers, often tracking Lyle's travels, as did the applications stories from the FEs.

A typical application was in the Antelope Valley, about 50 miles north of Los Angeles, the home of Edwards AFB. Accompanied by an Air Force Colonel, who was the frequency-control officer at Edwards, they parked the van alongside a phone booth at a desert intersection of Route 15 and 66, north of the base. The USAF problem was that there were three long-range surveillance radars, NASA, USAF, and FAA, all operating in S-band frequencies, on three separate mountain peaks, whose signals were interfering with each other.

It was the Colonel's job to straighten things out. The new HP analyzer, with its exceptionally-broad, 2,000 MHz sweep width, could see all three radar signals at once. The 60 dB dynamic range revealed the signal spectrum modulation "skirts," which were overlapping each other. The Colonel got on the phone booth phone (before the days of cellular), calling each radar technician in sequence, and unsorted them quickly. Lyle reported that, as he drove away that day, the Colonel offered him \$100,000, if he could have kept that demo analyzer.

Lyle's applications trip was a long one, and not as glamorous as one might think. Lyle would get to feeling sorry for himself. Although he technically reported to me, as Marketing Manager, maybe once a month Division Manager John Young, would come over to my desk in the morning, with the exclamation, "Goddamn, Jevons, he called me at home last night at 2:00 am to resign. I had to spend an hour talking him out of it."

John also agreed to an unusual process for Lyle's expense accounts. Lyle HATED bureaucracy, so John arranged for his own secretary to actually fill out Lyle's expense reports once a month. Lyle would mail in all his expense receipts, and tell her how much money he withdrew from a particular sales office petty cash, and tell her how much cash he had on hand at the beginning and end of the period. She managed to compute his line item expenses and John signed them. Can you imagine any other HP employee being allowed to do that? I don't think so.

The next year, Lyle shipped the entire van to Europe. He used the same technique of customer visits with the FEs. Lyle enjoyed himself in Europe, but at some border crossing, one afternoon, the customs people were giving him a hard time. Then they noticed several 3/8-inch puncture holes on the sides of the van. When Lyle was asked about them, he simply

smiled and said, "Indians." That made things more friendly, and he passed easily.

Lyle was a man of varied interests, one of which was that he was a confirmed theatre organ buff. He was personal friends with Howard Vollum, president and founder of Tektronix, with many contacts in an organization of theatre organ aficionados. He told of the last days of life for the massive Wurlitzer organ, at the Fox Theatre in San Francisco, before they tore down the old place. Thousands of theatre organ fans showed up for concerts that ran from midnight to dawn. Lyle was part of the behind-the-scenes crew which worked the fan room, where they had to keep wet towels on the drive motors for the air blowers, which heated up so much from hours of playing.

Lyle built his own aerobatic airplane, and flew it. He was a ham radio operator who worked on amateur radio high-tech experiments like moon-bounce tests.

He retired from HP to his own small fly-in ranch, just outside the boundaries of the U.S. Army's Fort Huachuca, near Tombstone, AZ. The base was a major testing area for military communications and battlefield signal environment simulations. We kept in touch. One day, Lyle called me, "John, what do you know about VAST?" I said, "It's a \$4 billion dollar program for the Navy, for automatic testing of avionics on U.S. Navy aircraft carriers. Each unit has 16 racks-full of equipment, running with a Varian computer, and costs about \$500,000. Why do you ask?" "I've got one."

"Wait a minute, Lyle, you didn't hear me. These things cost 1/2 million, etc, etc."

"I've got one."

And indeed he did. It turned out that in his work with friends on the MARS Ham Radio Club, at the base, the club got first refusal on any electronic equipment that was scrapped. So when this huge testing system was scrapped, the MARS Club brought it to Lyle's fly-in hanger, just off the base, to salvage it for the gold in the printed circuit boards and relays. The club used proceeds to help fund their operations. Lyle was asking me to see if I could find operating manuals for several pieces of HP gear that were part of the system.

In his retirement, Lyle signed on as flight engineer with a crew of retired airline captains, who were flying a 707 freight charter, to and from Australia. The mission was to fly back a load of 20 tons of mutton. The 707 was of British service, configured with Decca (UK) avionics, and some electrical controls that Lyle wasn't all that comfortable with. The flight out was uneventful, LAX to Hawaii to Guam to Adelaide to Alice Springs. The mutton was not frozen, with the idea of a short return flight. On the leg back to Guam, one jet engine bearing began to overheat. They shut it down, but did not declare an emergency, or report it to the ground, fearing any delay would cause obvious spoilage with the load. So they took off with four engines, and immediately shut down one. On to Hawaii, same technique.

On the Hawaii-to-LAX, other things went wrong. The shut-

down engine used no fuel, while the others used too much. But there weren't any on-board instructions on how to transfer fuel between tanks. In the process of trying to find the right switch combinations, an electrical fire developed in the control panels. This burned out their long-range radio. So Lyle got the fire out, used short-range radio to relay messages to LAX, via other in-bound flights, and finally landed with the mutton in LAX. Typical Jevons, overcoming adversity unabashed.

Carl Mahurin

Carl Mahurin was the Dean of the HP Service Department, and was probably the single most significant factor in establishing the culture of the way HP dealt with service customers. Carl was a graduate agronomist from Stanford. When WWII came, he looked for a job with industry and came with HP. Through his early assignments, he came to run the service department in the basement of Bldg 8, at the corner of Page Mill Rd. and Park Blvd in Palo Alto.

Carl was the consummate politician. But he knew innately the way to get what he needed. A typical example was his training department's move into new quarters in Bldg 11, at Page Mill and El Camino, in the early 1970's. By that time, I had transferred, to run a small department designing and producing light emitting diode (LED) products. My LED production operations were in the back of Bldg 11.

Since Carl's training group welcomed hundreds of customers to HP's world-famous training courses, Carl wanted a warm and friendly facility, with carpeted floors, drapes, reception areas with comfortable sofas, etc. He assumed that such plush surroundings would fail the budget test with his boss, Noel Eldred, and the long-held HP culture of tile floors, no carpets, and spare accommodations. What to do?

Carl enlisted Jane Neely, wife of Norm Neely, our California representative, and senior spokesman for sales techniques. Jane had done the interior decorating for perhaps a half-dozen of Norm's far-flung sales offices. They were well-known for warm hospitality, and a Spanish architecture, each with their "Cahuenga Room" bar for after hours informalities .

Jane designed for Carl a perfect combination of orange carpets, beige sofas, patterned drapes, classy coffee tables, etc, for a mere \$50,000 budget. Which boss Noel Eldred promptly vetoed. But Carl was ready for that. He called Jane to tell her the bad news. Who promptly called Norm, who called Packard. Who called Eldred, and got the decision reversed. So Carl got his elegant facility for customers, and it was a grand spot. No bar in the factory, however.

Carl got many other things done, through the years, through sheer dint of personality. Although his personal style was very reticent, he was tenacious. In the earliest stages of the industrial video technology, Carl felt strongly that HP needed a video studio for modern training purposes. In later years, John Young remarked on the Mahurin style. John noted, that at the time, it was impossible to provide an economic justification for a video studio. Carl just knew HP should have one.

What he did was to borrow or lease a black/white camera and

minimum equipment, for "trying out" some techniques. He also made sure to enlist both Dave and Bill to be test subjects for "video memos," to be used for passing the word about various management initiatives. By involving top management in parts of the programs and thinking, he set things in motion for the superior studios and programs HP enjoyed in the 80's and 90's, until other processes began to dominate. But he often avoided a true economic justification, as we have to prepare today.

Carl's service department of the 1950's was affectionately called the Mahurin Charm School. The hiring and internal training practice those days was for each new marketing engineer to spend up to 6 months in the service center. They worked on the bench, repairing instruments, answered customer phone calls and wrote service letters to customers. Carl himself edited the letter replies, and it often took 3 or 4 tries, to get the right empathetic tone that Carl insisted on. Those customer principles were never forgotten.

In spite of the usual 6-month training period in the service dept, I only spent a total of one day in Mahurin's Charm School. After about 3 months out on the production line, I moved into the basement of Bldg 9, to take up my period of service orientation. Bill Terry had just finished his training there. I think on my second day there, Carl Cottrell, from marketing, came down to find me, and to tell me that his workload in regional sales engineering was so high, that he couldn't afford to let me stay there for the normal training. So, I immediately moved upstairs, and began my work in sales engineering. I had to pick up Mahurin's "charm" by observation.

The basement of Bldg 9 was an afterthought. It had originally been added under the office structure, intended by Ralph Lee as a finished product and in-process storage facility. When space ran low, Mahurin's Service Dept was moved downstairs. It was a bad fit, because the ceiling height was not adequate for normal industrial benches and personnel, but there they had to stay for several years. Electric distribution was way inadequate, and I remember being appalled when I saw an electric distribution/circuit breaker box, with an electric cooling fan mounted on the front. It was blowing air into the wiring to keep it cool enough to prevent tripping the circuit breakers. It was obviously a city code violation, and I was surprised that most of the people down there took some pride in working under those conditions.

One interesting tidbit from my short previous period on the production line. Our line was producing HP 494 travelling tube amplifiers and HP 608 signal generators. My first job was mechanical assembly on the very front end of the HP 608 line. It consisted of bolting together several different sheet metal chassis parts, and adding some components like the power transformer. So, here I was, a new kid from the Midwest, energetic and green, assembling those starting chassis like crazy. I think I had stacked up about 10 finished subassemblies, when one of the senior wiring women came over to me, and quietly told me, "We do three an hour." So, in spite of the non-union conditions on our production lines, I had just learned the theory of pacing and the long-distance run vs. the sprint. (And working as a team.)

Carl had a preference for military technician retirees, who had been through the U.S. Navy training schools, and had worked on electronic systems, were ideal for HP service work. So he initiated the practice of hiring large numbers of navy techs, who were being mustered out of the Navy at Moffat Field in Mountain View. We also obtained a number of officer-level retirees, among others, Chuck Ernst, whom Dean Abramson named Commander Whitehead, for his white hair. Chuck later assumed Carl's position when he retired.

One of Carl's innovations was to personalize the training courses held in his schools, in Bldg 18. He did this by including in the usual 3 weeks of high tech courses, a short tutorial dedicated to "Tasting California Wines." It was presented by Fred Waldron, a serious wine expert in his own right. Since the neophyte field engineers were all the way from highly sophisticated people, we had hired from competitors, to brand new engineers right out of college, the course was always well received. Moreover, Mahurin would invite high level managers from HP to the tasting, held after the tutorial on the tasting process. Fred scheduled this event for late in the afternoon, before all left for dinner. This often included Dave and Bill and John Young, and many others.

I recall talking with a fairly senior, new hire FE at a wine-tasting reception. He said, "This is absolutely amazing. Before HP, I have worked for the Burroughs Company for 12 years. I was working out of the Detroit office, where I had been hired. I never was allowed to visit the Burroughs headquarters, I never got visited by any headquarters personnel in the field. Here, I have been with HP, for about 4 months, I am here learning the company products, visiting your factories to see the production lines. Just a few minutes ago, I was shaking hands and talking personally with John Young, the president of our company, that is \$5 billion dollars large, who was sincerely interested in finding out about my Burroughs' experience. What an amazing company!"

A final story about Fred Waldron. His primary job was training for the HP intensive care monitoring systems from Sanborn. These were highly-sophisticated systems that performed amazing monitor actions for deathly ill patients. Well, as luck would have it, Fred himself was felled by a heart attack, and landed in Stanford hospital. When he woke up he found himself wired up to—what else—an HP system. He joked afterward that at that moment he prayed that all his training for field sales and service engineers had taken hold. He came out just fine.

Egon Loebner

Egon was another of the true geniuses who populated the HP Laboratories. He had joined HP from RCA Advanced Laboratories at Princeton, NJ, as an expert on electroluminescence. I got to know Egon, as my little product development group at HPA Division was beginning to develop light emitting diodes for numeric indicators.

There were so many process variables in those days, it was a wonder that we ever did produce semi-conductor diodes of Gallium-Arsenide-Phosphide (GaAsP), which would emit red light. Our manufacturing and design guys were always calling on experts in the HP Labs, such as Loebner, Bob Burmeister,

Paul Green, and others who helped solve those nasty processing problems.

Just one example; in processing GaAs wafers into diodes, there were something like 32 different process steps from start to the end, and the whole cycle took maybe a month. At one point, we bought ourselves a simple new mechanical thickness gage, which were used to slide new wafers under a probe, to measure thickness of approximately 0.010 inches. Except that someone forgot to throw away the new brass probing point, that came with the machine, and replace it with plastic.

It seems that just rubbing the brass probe across the wafer was enough to transfer copper atoms from the metal probe onto the wafer surface. Later, in the diffusion furnace, those few copper atoms diffused into the crystal lattice structure, just enough to kill the light. Worse, it took us a full month, and hundreds of wafers in production, to find out that entire batches were ruined. "Those were times that tried men's souls," and we often needed expert help.

Other than his profound technical contributions (there is a hard-bound book in HP's libraries, created in memory of Egon, which covers his lifetime contributions at HP), I remember Egon for two particularly personal events.

1) Once, in an informal setting, Egon and I were discussing a particular graphic used in electro-optics, called the CIE (Commission Internationale De L'Eclairage) Chromaticity Diagram. In the optical business, it defines dominant wavelength and color purity. Egon mentioned that in his later college years, he had once postulated, that the different colors of light as shown in the graphic, might well be replaced by political viewpoints. So he undertook a simple college project to survey some hundred of his fellow students and professors, and plotted their political positions on a similar graph. It was surprising to me, but not to him, that his survey showed people's political spectrum was distributed very close to the color spectrum.

To me, it showed his exquisite curiosity, and his cross-disciplinary approach to life.

2) In 1978, I was National President of the National Conference of Standards Laboratories as mentioned before. I was looking for a banquet speaker for our annual conference in Los Angeles. So, I got a commitment from Eberhardt Rehtin, who had served with Dave Packard at the U.S. Department of Defense, in the early 1970's. When Packard returned to HP in 1972, he convinced Rehtin to come with him. Rehtin had served previously with NASA, and was a technically brilliant and multi-faceted man with a charming speaking personality. I felt he fit the bill nicely for our banquet speech, which had technical people as well as spouses with only a shallow interest in our nation's technology.

About a month before the conference, Rehtin called and cautioned me that he probably would not be able to make his engagement. As it turned out, he had already been hired away from HP by the Aerospace Corp, a major program contractor for the U.S. Air Force. So I scrambled to find a replacement speaker.

Luckily, Egon had just returned from a 3-year tour as a government loaned executive, serving as a technical liaison officer at the U.S. State Department in Moscow. In that role, he had organized cross-liaison trips of hundreds of technical groups and committees who were travelling in each other's countries. Subject matter included everything from welding technology to space travel, as the two countries were beginning to open up their technical relations in a good way.

I felt that Egon's observations of the Russian technology of instrumentation and industry would be interesting and current and valuable to our dinner guests. After his after-dinner speech with appropriate slides, during which he praised certain of the Russian technologies, the question and answer session deteriorated quickly. A metrologist from Rockwell Corp., Anaheim, went on for about 5 minutes trying to refute Loebner's positions. The Master of Ceremonies asked the questioner to finish, and frame his question, but he insisted that he **MUST REFUTE** Loebner's positions. When several others in the audience rose to back the questioner, I, as president, took the microphone and ended the after-dinner meeting.

As the dinner broke up, the original questioner came up, and almost got in a fistfight with the Master of Ceremonies. I was flabbergasted by this turn of events. Egon just smiled.

Later, Egon and I flew home from LAX, on the same flight. We had a drink in the lounge, while waiting for the flight. It was there that he showed me his forearm, which had the distinctive 5-digit serial number tattoo of the WWII Jewish concentration camp victims. It turned out that the questioner had been a German U-boat commander during WWII, and that he had immigrated to the U.S. to join some of the Rockwell teams, that were working on inertial guidance for inter-continental ballistic missiles.

As a naïve mid-westerner, I was extremely unknowledgeable of so many of those awful political and racial events of WWII. Egon carefully informed me that many Germans could not conceive of any good technology, whatsoever, coming out of Slavic races like Russia or Poland. Poland was his country of birth. Then he proceeded to tell me of his narrow escape at the Auschwitz death camp.

It seems that by the time he got to the camp, someone realized that his engineering background could be put to use in the camp's facilities dept. It turned out that a major dysentery epidemic had just broken out, and since Berlin was on the same river, but way downstream from the death camp, there was a remote danger the camp's sewage germs might infect Berlin. The camp commander decreed that their sewage system must be brought to top form. So Egon got to design and specify equipment and pipes for the construction. He took great delight in telling me how he massively over-designed the pipes, such that he used up enough extra steel, that might have manufactured many Nazi tanks, a number I can no longer recall.

John Young

John Young was in the HP Class of 1957-58, which was an attempt by Packard to refresh the management ranks of the

company. Virtually all of the top and middle management of HP in the late 1950's were middle-aged men, who had grown up in the WWII era, and joined the company well after their college age. Dave and Bill finally realized that they had been neglecting the pipeline of eligible young managers, ready to move up into the management ranks of the company.

In the years since 1945, the Graduate Schools of Business in the nation had thrived. There was the highly-successful example of Robert McNamera's "Brain Trust," a small group of whiz kids, who he organized at the Pentagon, during the WWII war years. That team created what came to be known as early "operations research," later to be called systems analysis. McNamera had previously come from the Ford Motor Company, and achieved production miracles, in materials and production, during those wartime periods of massive growth and serious materials shortages.

Dave and Bill decided that they would begin to recruit a group of MBA's into HP, to groom them for later management. This group included some very successful young men. John Young, Tom Perkins (later of venture capital fame), Dean Morton, Jim Treybig (later of Tandem fame), and many more.

John Young, a native of Idaho, grew up in a small town in Southeast Oregon, Klamath Falls, and earned his EE degree from Oregon State. He served a tour in the USAF, part of which was on the personal staff of Colonel John Stapp. Stapp was the brilliant research commander, some would say fearless, of the early Holloman AFB rocket-sled experiments. This included strapping himself on the front of a rocket sled, to test the process of bailing out of an airplane at barely-subsonic speeds. He didn't actually bail out of the sled, just tested human endurance during the speed run. John then obtained his MBA from Stanford, and worked his MBA summer as an intern in HP's finance department in 1957.

Upon full-time status, John was attached to the marketing department, and quickly was appointed Regional Sales Manager for the New York/NJ/Philadelphia Representative organizations. I moved from Microwave Application Engineer, to assist him. We used to joke, that our titles should really be Regional Sales Clerk. Our lowly status was confirmed at quota-setting time, because when the Rep owners visited to negotiate sales quotas for the next year, they would talk to John and me, for a time, then excuse themselves, and go directly to talk with Eldred and Packard to set the real sales quotas.

After 2 years, John was tapped by Finance Manager Ed van Bronkhorst, to run a project study which would lead to purchase of all the independent Rep companies. As one could imagine, such a project was fraught with political landmines. Each of the owners were personal friends of Dave and Bill, each was fiercely independent, and no one could be sure whether they would consider getting merged into the big corporation, and all its bureaucracy and rules.

The Rep acquisition program went so smoothly, no one could believe it. In fact, the very first company to sell out to HP was Earl Lipscomb of Texas. He, along with Tiny Yewell, of Boston, were both outspoken and overbearing. But those were

the first two companies to sell out to HP. In our regional sales offices, we were told to anticipate that many, if not most of the reps, would choose to cut HP adrift and remain independent.

So we had made plans for that contingency. We identified key senior field engineers in the Rep organizations we managed, approached them and contingently offered them management positions, in a replacement company field organization. The plan wasn't needed. Only 2 of the 13 Rep organizations, and the smallest, chose to decline the HP offer. No doubt they could all see the huge advantages to be a part of the HP family.

When the four charter divisions were established in 1962, John was appointed Marketing Manager for the Microwave Division (MWD). Two years later, division manager Bruce Wholey transferred to manage the Sanborn Medical acquisition, and John rose to Division Manager. In a very short time, he was to have a massive impact on HP management processes, especially on the new product strategy creation process.

He moved up through the ranks to Electronic Products Group Manager, to Vice President, and from 1978 to 1992 was President and CEO of the entire corporation.

I reported directly to John for about 6 years. He was undoubtedly the most incisive and well-organized person I have ever known. Dave and Bill were "intuitive" managers who grew into greatness, by sheer common sense and humanity. John brought his value to HP in a well-organized approach to professional management. It was his establishment of the Microwave Division new-product creation process that made that division grow from about \$22 million in 1964 to \$75 million plus, in 1969. The normal growth for HP Test & Measurement in those days averaged 15% per year, or doubling every 5 years. John more than tripled our sales revenues in 5 years.

Even more important, as described in the SPD Profile section, he developed a whole cadre of young managers, ready to take their place in future organizations. They cut their teeth on small product lines, defending them from competition, and creating dramatic new introductions, while still under the guidance and counsel of older and more seasoned managers.

John's memory was prodigious and legendary. When paired with Paul Ely, the MWD R&D Manager (below), wonderful things would result. Paul was relentless, highly aggressive, and a dominating conversationalist. Product strategy meetings were scheduled every Wednesday morning, religiously. Since there were 4 product groups in the MWD, the division management team, Young, Ely, Doyle and Minck would hear from each team once a month.

I recall in one meeting, Young was tilted back on his chair, leaning against the wall, with his eyes sort of closed. Ely was stating something like, "We are doing this, on this project, because of A and B and C." John tilted forward, his chair hitting the floor, and said, "Wait a minute, Ely, a year ago, on this same point, you said almost the opposite, D and E and F." Without a moment of hesitation, Ely rebutted, "Yes, but G

and H and I, because of J and K and L."

In that fabled Microwave Division, John Young's young second lieutenants became the "Class the HP Stars fell on." In a way they were just like the famous West Point class of WWII generals, who all came from the same graduating class. The Microwave Division's management process became highly visible, since Packard would point to Young's successes, in revenue growth and profitability. It became known as the "triad" organization, with marketing, R&D and manufacturing sub-managers, trusted to run their own small businesses of perhaps \$5 million a year in revenue.

In a slightly derogatory tone, the movement of so many of those successful Microwave Division managers, into other organizations of the company became known as the "Microwave Mafia." A long line of young men moved to positions of great influence in the company, and brought along with them the smooth organizing principles, that John established. Paul Ely, John Doyle, Doug Chance, Ned Barnholt, Jim Ferrell, Dick Anderson, Hal Edmundson, George Bodway, Dick Hackborn, Harold Kramer, Al Steiner, Dave Weibel, Scott Wright, Tom Lauhon, Brian Humphries, Marc Saunders, and many more.

John was a knowledgeable manager. He practiced MBWA religiously, visiting production operations regularly, and learning of current problems. One morning, just after we arrived at work, John and I were chatting over a cup of coffee. One of the plating shop process managers came up, and urgently told John of a possible problem, that had happened about 10 pm the previous night. It seemed some excess acidic chemicals had inadvertently been released into the Palo Alto sewer system. John said, "No problem, I know all about it, and it was taken care of. The city was notified. I was here last night, and learned of it when I was down having coffee with the night crew."

In later days of world-notoriety for our gigantic \$75 billion HP corporation, it might be forgotten that it was John Young, who took over as CEO in 1978, when the company revenue was \$1.9 billion, and managed it until 1992, when he left with a revenue of \$16.4 billion. In the process, he led HP into the fast-growth areas of printing technology and computer and PC initiatives, that were exceedingly complex. I assert that he deserves extraordinary credit, but his recognition seemed to disappear rather quickly, with the entry of the next CEO, Lew Platt. I believe that is unfortunate and sad.

Michael Malone's book, *Bill and Dave*, relates the growing rift between Young and Packard in John's last years as CEO. It may have Packard's age showing or the fact that Young started working with Presidential candidate Bill Clinton on high-tech business issues. The new book by House and Price, *The HP Phenomenon*, gives extra credit to Young for the complex computer business strategies that he developed during a chaotic era of computer system rivalries. At one time HP was selling computer products with FIVE different operating systems. Remember RISC, and Joel Birnbaum?

Paul Ely

Paul Ely was a dominating (and domineering) personality. He had already made his mark on the microwave industry, long before he got to HP. From Lehigh University, he joined the Sperry Company in Long Island, which was a major system contractor to the U.S. Navy. In talking to his Sperry contemporaries later, I learned that Paul was pretty insufferable in his years at Sperry, Great Neck. He soon moved (or perhaps was moved) to the Sperry Microwave Division in Gainesville, FL, where he rose to become R&D manager for that facility, with a product line that partly competed with HP. Yet, he had set his sights on joining HP in time.

Upon joining the HP Microwave Division, Paul took on several projects, in both of which he had zero management responsibility. He was the single person involved. But he was so intent on working within the HP meritocracy, that he was willing to submerge his ambitions for the time when he would be called upon. Which he was, once Young rose to Division Manager in 1964.

On balance, Ely accomplished an amazing amount at HP, although several of his microwave product success credits were in the pipeline and almost introduced, by the time he took over R&D. The HP 8551/851 spectrum analyzer was an overwhelming winner. The HP 8410 network analyzer was Paul's baby, however, and he noted later that from way back in his pre-HP microwave engineering days, he was totally frustrated by the old, tedious slotted line measurement technology. So, when the dual-sampling, down-conversion, sweeping network parameter measurement technology became possible, he pushed it with everything he had. He also coined the sales slogan "stamp out slotted lines," for the network analyzer

One of Paul's greatest contributions to the RF/microwave technology, was his aggressive advocacy for microwave thin-film microcircuits built on single crystalline sapphire. This ability to integrate multiple microwave functions onto a single substrate allowed dramatic improvement in the functional performance of subsystems. This was true, since in any microwave sub-system, the inter-connections between functions such as mixers, amplifiers, filters, and others was reduced to nothing because those functions could be grouped next to each other on the same substrate. They were connected with tiny gold bond wires, rather than coax connectors and external cables.

Paul's budgets for the technology, along with the lab manager, George Bodway, were always growing, and took over a lot of the available resources. In fact, there was rumor that some of the engineering project expenses were so large, they had to be capitalized. It was strict HP finance policy to expense ALL engineering as it accrued. When Paul left the SPD to take over the computer operation, he took his finance manager with him, so I guess we will never know. Yet, the performance of dozens of HP RF/MW products were so enhanced, that we know it was the right decision to push that technology.

He did push sapphire technology too far, finally. At one point, Paul decided it was important to get HP into the CATV (Community Antenna TV) distribution amplifier business. This was crucial because the nation was being wired for video cables, to support the new way to distribute TV without over-the-air transmission. Paul signed several very large quantity contracts, but insisted that the sapphire technology be used. But, since he had to out-bid other companies, which used simple ceramic or PC board technology, their production costs were much lower, and our production was not profitable.

Management style. Paul's management style was surely mixed. While he always gave the impression of consensus and collegiality, there was little question that he dominated his people. He would sit back in a product review meeting, and let the group manager present, but then he would chime in with directions laid out, yet it would seem to be from the group.

I recall one momentous meeting, where he held an off-site get together at his house. He was going to reorganize the engineering dept, and I was invited as an observer from marketing. He actually got all his leaders to participate in a new organization change, with products and manager assignments up for grabs. It was something I would have never attempted, because of the personal minefield it presented. Each person there had their career on the line, real-time, in the ongoing discussions. But he handled it masterfully, and although some people gained and some lost in position, I think we did end up with a better organization and several better people.

Other section managers and project managers, who worked for Paul, might give more-mixed opinions for his lack of accepting consensus, and his overbearing ways of cutting off discussion for projects he didn't want to support. Interestingly, in a number of cases, those managers succeeded in maintaining projects, that they knew HP needed, in spite of Paul's having thought he cut off all spending.

Frankly, I did lose track of Paul's career, after he moved to the HP computer operations. My observation was that he literally saved that computer group from disaster. It had previously gone through about 10 different managers, including some pretty heavyweight people, Bill Terry, Tom Perkins, George Newman, Carl Cottrell, Bill Gross, etc. But it seemed that they were trying to be another IBM, with seriously overlapping product and software strategy committees, who were mired in bureaucracy.

Paul came in, and said, "I want a Mr. 1000, Mr. 2000, and Mr. 3000, and all other committees are cancelled." He also said, "I want distributed computing as a strategy, and silicon-on-sapphire technology (SOS)." SOS was quite different than the sapphire microcircuits mentioned earlier. In this technology, silicon vapor was deposited on top of sapphire crystalline surfaces, to make thousands of transistors, which used very little power. The problem was that silicon and sapphire crystal structures had different atomic spacing, so as the silicon grew in thickness, it would develop defect lines randomly on the surface. If a critical tiny transistor element crossed over one of those defect lines, it would fail. So the

yield of that process was awful, even if the low operating power consumption was excellent.

I used to eat lunch with Barney, occasionally, in the HP cafeteria, when he would come to my table, if all his other lab friends weren't there. I asked him once about the viability of SOS, and he just denigrated it. He said that the lithography process experts were making such fast progress, in the packing hundreds more devices on regular silicon, that the low power of SOS was not going to win. In addition, he said that the very defects inherent in the crystal lattice spacing differences would doom it, except for very specialized purposes like atomic weapon electronics, where they had to be impervious to nuclear radiation. Those radiation designs used design layouts that were more redundant and less efficient, to preserve the advantages that SOS technology held for radiation resistance. But they never made sense for HP type products.

The working environment. It should be noted that Paul espoused a human-scale philosophy at work. More than once, in informal meetings, I heard him state that a business environment is like a family. He proclaimed that it was important to remember that most people spend more than 1/3 of their waking hours working, including weekends at times. It was during Paul's term at the Microwave Division, that the office rules were changed to permit growing plants to be cultivated in personal offices and cubicles. It provided a simple personalization of an employee's office, and was a real benefit in terms of ambiance.

Desks in the "bullpen." It was Dave and Bill who preferred the "bullpen" approach to office organization, and only later in the 1990's, were cubicles for ordinary employees accepted. I have always thought Dave felt that way because he was so tall, and he could come outside his office, and look over the sea of desks to see if the person he wanted was at his desk. Certainly private offices were verboten, except for Dave and Bill themselves. When HP bought the Fairchild building on Arques Avenue in Sunnyvale, we found 12 private offices along the entire front of the building. The first thing HP did, was assign 3 people to each of those previously private offices.

I have always agreed with Dave and Bill's preference for the "bull-pen" approach to desk layout. While it always looked a lot like what we saw in aerospace companies, the buildings of the Stanford Industrial Park complex contained rows and rows of desks.

Each building was 2 floors, each of which was about 1 acre of space, 200 x 200 feet. That meant, typically, hundreds of employees working in pretty close proximity. One might have assumed that normal crosstalk would have made conversation difficult, especially when talking on the phone with field engineers and customers. But, the design of the building's air conditioning was made to introduce a broad spectrum of audio noise into the big room, which tended to mask voices from across the room. One could experience this clearly, when the air conditioner would be turned off for some reason, and you could easily hear conversations from way across the room.

One main reason I liked the bullpen approach was that managers were usually seated amongst the people who worked for them. For brand new-hire engineers, this was extremely valuable, because one could hardly avoid listening in on the way their manager handled customers, field personnel and internal cross-department issues. You heard and learned from the closeness.

On the other hand, one negative aspect of the no-partition culture was that someone like Paul, who was loud and assertive, would blast out all across the whole floor. His Division Manager office was right in the middle of Bldg 5U, and whenever he was holding forth, everyone in the whole floor could know his mood, good or bad, and his effect on the person who was in the office. Sometime it could be quite embarrassing, although one has to think Paul might have intended it that way. He soon had a private office, enclosed all the way to the 30-foot slant ceiling, and built along the north wall of Bldg. 5. Most people breathed a sigh of relief. And I soon left microwave marketing management and embarked on my career in light emitting diodes at HPA.

Recruiting marketing engineers. It was also during Ely's reign that we formalized our college recruiting processes. By the late 1960's, this program was a massive annual commitment to find and recruit the best brains of our countries' engineering colleges and universities. The scope was huge, and expensive. It involved organizing several dozen HP recruiting teams, each assigned to several colleges. The team was responsible for establishing good relations with the engineering department heads and top professors. This allowed HP to identify top candidates early, make contacts, and often offer them summer intern jobs after their junior year.

The teams did on-campus interviews, and invited the key candidates to visit our labs around the country, where full-day interviews were conducted. All the data from multiple college interviewers were combined late in the day, to establish which people would receive a factory trip, or even a coveted job offer, before flying home. Thousands of college engineers were evaluated on campuses, hundreds were invited to the factories, and hundreds were hired each year.

Along about the late 60's, Ely and I began to observe that our marketing and production engineer needs were being filled by "technical washouts" from the lab. Rather than being a negative image, these were engineers who simply found that they didn't enjoy the on-bench work of design engineers. We reasoned that the cause was in the very fact that on-campus recruiters were, for the most part, lab engineers. It was natural that they would try to hire people like themselves, i.e., 4.0 average students. But what marketing was looking for were those students who published the student technical magazine, or were president of the student IEEE, and not necessarily a 4.0 average type of person.

Paul was quick to agree that marketing needed to insert some marketing personnel onto the recruiting teams, so that they could be part of the identification of appropriate personalities of recruits more suited to our marketing needs. The new process made a distinct difference, and in just a year or two, we were realizing many more new hires, who were directly

suited to the marketing and manufacturing and field sales personalities.

After several decades of loyal HP service, Paul left the company to seek other opportunities. I won't presume to understand the reasons why, but clearly he was telegraphed that his name was not on the lists of future CEO candidates. Those kinds of decisions are made by people 6 levels higher in management and strategies than I was ever involved in. One can read the books about Platt and Carly and those momentous moments when management sequences are determined.

John Doyle

John Doyle was Microwave Division Manufacturing Manager during the explosive growth years of the 1960's. He emigrated from the United Kingdom to Stanford University for his graduate degree, and hired on to HP after graduation. John had a wonderful sense of humor, which belied his seemingly taciturn exterior. He humorously described his own move to the USA, since in an average British family, he said, the first son inherits the Baronial Estate, the second son goes into the military, and the third son, the ministry. The fourth son goes to the colonies. And that is how he ended up at Stanford University.

MBWA. Packard was long understood to have pronounced the HP management style as MBO (Management by Objective), as opposed to Management by Directive. MBD meant that orders came from some central management and planning team. But, I believe that it was John Doyle, who coined the term, MBWA, (Management by Walking—or Wandering—Around). John was a keen student of the management processes, and I was always impressed with his ability to listen to his workers.

He seemed to make it a practice to NOT stop at his desk when he first came to work in the morning, instead walking among the production areas, a different one each day. By doing this, he found out if there were problems that he might need to give attention to that day. It saved delays in the system, if he would have had to wait for a written report, and it endeared him to his troops.

Stanford days. John told me once, how he made some income during his Stanford years. Once a week, he would go to the Mark Hopkins hotel in San Francisco, and with safety ropes attached, would go around the restaurant on a narrow ledge, washing the windows of their 26th-floor restaurant, Top of the Mark. He said the heights never bothered him. Until one day, although he supposedly had safety lines attached to the soapy brush, it somehow came loose, and plunged down 24 stories, to land on a rooftop. He said as he watched it recede, he lost his confidence. He pulled himself up, went inside and resigned, and never went back to that job. Who could blame him?

New plant in the UK. HP's first international production was established in Boeblingen, Germany. But when the time came to place another plant, this time in the United Kingdom, John was on the team which undertook the planning and building of the new plant in Bedford, just north of London. While this

program took John back to his mother country, he used to tell how he was appalled by the social class system in that country, looking at it from his perspective as a newly-minted American. In their negotiations with the British banking community for financing and lines of credit and other loans, John told of meeting with bank higher-ups in their formal dining rooms. These meetings included the private, mahogany-paneled dining rooms, with a costumed waiter assigned to each person at the table. A very exclusive management perk.

John, of course, made sure during the establishment of the HP, Ltd. plant and recruiting, that none of that personal caste system made its way into the HP structure.

Automation in the fab shop. John was also part of the manufacturing team, which planned and installed the "Milwaukee-Matic" automated milling machines, which revolutionized the short-run type of fabrication processes HP used. The system had no computers as such, just stored memory and high mechanical precision, needed on much of our microwave product line. I seem to recall that the early designs were programmed with punched paper tape. I believe that HP ended up with 5 or more of these automated machines. In the end, however, it seemed like the team that operated that production center, had built an empire, which resulted in exploiting work for the machine center that could have been done cheaper on other processes.

Dick Anderson

Dick had a long string of distinguished technical achievements in the Microwave lab before he left to run the computer group. In the early 1960's, he started in the project for the microwave half of the hugely successful HP 8551A spectrum analyzer, lead by George Jung. This involved serious technical breakthroughs, in building a sweeping-while-phase-locked BWO, lots of broadband subsystems, and other components like a manual 60 dB step attenuator. He then moved on to manage the equally successful HP 8410 network analyzer, and contributed mightily to that world-class innovation.

But Dick will probably be mostly remembered, for his highly-visible industrial expose, about the poor reliability of U.S. semiconductor products. When Dick took over HP's computer divisions, our production engineers were beginning to understand how important it was to temperature-stress all components, before assembling them onto printed circuit boards. It was part of our Class B environmental testing mentioned later in this paper. The result was that a major project was established to temperature-test all incoming semiconductors, in 100% screening tests. The results were devastating.

The U.S. semiconductor industry of the time was under tremendous production stress because of the huge increase in computers and printers and a variety of technology innovations. It was fairly well known, that the going rate of failure for incoming active-component inspection, was on the order of 0.1%, which was pretty bad in itself. But the real problem was that the industry was almost totally blind to customer protest. Worse, the Japanese semiconductor industry

had adopted the preachings of Edwards Deming, the Quality guru from the U.S., and his gospel of total quality processes. Japan had dramatically improved their production processes, and were regularly achieving failure rates on the order of 10 parts per million (10 ppm was 0.0010%). 100 times better than 0.1%.

Dick's HP testing project summary report revealed these stark statistics, and he took the bold move of going public. The technology business uproar was immediate, and loud. Coming from HP, the data could not be denied, and the spotlight, which then swung to the cavalier attitudes of the semiconductor kings, really began to have an effect. One big part of the action was that U.S. user companies starting to sign big contracts with Japanese suppliers. But the true reward of Dick's gutsy action was that American semiconductor companies finally GOT IT. They began sweeping retrenchments, to establish their own total quality programs, which in a few years got them up toward the superior quality levels that Japan had shown were possible.

One sidebar story to this event was instructive. HP's Microwave Division had signed some large supply contracts with a nationally known semiconductor company in Santa Clara. Large quantities, and a known requirement, meant low prices. Yet, once we had established burn-in racks for incoming inspection, the failure rates went up to 2% or so.

So we began to ship back enormous quantities, based on sampling burn-in inspections. Soon the selling company asked for a conference, and of all the stupid arrogance, they stated that they were going to have to re-negotiate the contract price upwards. Their reason? They never figured they were going to get back so many bad units. Needless to say, we cancelled that stupid company's supply contract.

Another not-so-amusing semiconductor tale. One of HP's Medical Division key managers, Ralph Hanson, decided to leave HP, and bought a small, growing company that was in the implanted heart monitor business. They were in the \$5 million-a-year category. Because their products were implanted into someone's chest, they were super careful to design ultra-reliable circuits. For their components, they standardized on buying only military-grade (MIL-STD-883) semiconductors, reasoning that the extra screening tests that the manufacturer was required to do for the military applications, would assure them reliable products.

On a really black day, Hanson received a letter from the Semiconductor Company informing him that for the last several years, the manager of their quality control department had been falsifying tests and test data to cover up serious reliability deficiencies in their mil-spec product line. And, while they would invoke their standard contract clause, disclaiming any contingent liability, they would be happy to replace all of their deficient products that had been shipped, if he would furnish paperwork showing what he had bought. Well, getting replacement transistors and ICs was the least of his problems, because the rest of them were inside hundreds of human beings' chests. As it would turn out, the recall program almost killed that little company. But it shows again, the arrogance of the U.S. semiconductor industry in that era.

Bill Terry

Bill and I joined HP within 6 months of each other, and I have always considered him a good friend, although he progressed much higher in management. Bill had an abrasive personality, although he could be very friendly when he wanted to. A lot of his career was devoted to running the oscilloscope programs in the company, and with the continuing times that HP got beat up by Tektronix, it was no wonder that those HP managers sort of grew chips on their shoulders.

Bill came into the company in the HP Class of '58, although he was not an MBA. So he never quite fit the manager mold of those like John Young, Dean Morton or Tom Perkins. He, as almost all newly-hired engineers, spent about 6 months in the Mahurin "Charm School," working on instrument repair, answering customer complaints, and then spending several months out on the actual production lines.

After spending some years running the Colorado Springs scope operations, Bill returned to the Bay Area, and spent several years as one of the long line of "temporary" czars of the HP computer operations. None of them succeeded, until Paul Ely was assigned to that formidable task. Bill moved to take over the Test and Measurement operation, and grew it very successfully, for more than a decade, retiring from that position in the 90's.

One of Bill's best manager traits was his little Terry-grams, personal notes he sent to people whose work had come to his attention. He was an avid reader of industry publications, so any lab engineer who succeeded in publishing a technical article in a trade magazine would get a personal note from Bill, "Nice Job," Bill Terry. It was well-received attention for everyone.

Doug Chance

My marketing organization chart of October, 1968, shows some fresh-faced young engineers among the 80+ people in Microwave Marketing. Among these were several who were destined to greatness at HP and elsewhere: Doug Chance, Al Steiner, Dick Hackborn, Scott Wright, Doug Spreng, Doug Lanterman. In earlier-year charts there were a few other names who moved well up in HP management too: Ned Barnholt and Murray Horton. Lanterman left for ATL, a countermeasures system company and rose to head their System Program. Murray went off to electronic sales for a competitor, but found more fame later as the founder of The Good Earth restaurant chain on the Peninsula.

I always felt that Doug Chance had most of the management attributes of John Young. He was incisive, strategic, intelligent, and a real team player. In my group, he was Product Marketing Manager for Signal Generators. While the signal generator line had always been a cash cow for HP, the 1960s were a time when we had to starve development there to allow R&D money for the expanding lines of spectrum and network analyzers and automatic network analyzer systems.

But signal generator spending was coming back and Doug led the strategies for many of the new transistorized products which offered far more than just AM-FM-Pulse modulations.

Frequency synthesis was making programmable sources possible, and developments of components made programmable amplitudes possible.

After I left the MWD in early 1969, and after a few months under Ken Tingley, Doug was promoted to my marketing manager job, under Paul Ely who had taken over the division when John Young moved up to Group Manager. Doug managed a rapidly-expanding and diverse line of products which even included tape recorders. These had been attached to Microwave Division after the acquisition of Walt Selsted, a senior R&D manager from Ampex. Because MWD had a massive fabrication and machine shop capability, Hewlett decided that it belonged there to start. That line moved soon to San Diego Division to combine with the X-Y recorders that had been acquired from Moseley.

At about 1970, MWD was bursting at the seams with the huge success of the spectrum and network analyzers, and the re-emergence of modern signal generators. Doug was appointed to the team studying where to move a new division. They studied locations at Albuquerque and Reno and Santa Rosa, which ended up getting the decision. Then Doug took over as Division Manager for the new venture. With a product line of spectrum and network analyzers, Santa Rosa bloomed. The site also included an advanced R&D facility for microwave microcircuits and components, under George Bodway.

I lost track of Doug in succeeding years as he moved down to the computer operations in Cupertino, and moved up in high management responsibilities. Later, in the early 1990s, Doug left HP to take over CEO responsibilities at Octel, a Fremont-based company that was a leading supplier for voice-mail products. Doug later joined a number of other company Boards of Directors. But in his HP career, Doug was a true contributor to the success of many ventures at HP, and a credit to his management skills.

Ned Barnholt

Ned came to my marketing department in the mid-60s, after a stint in the R&D lab, and I think a short time in production. I recall being a part of his interview team several years before, and our agreement was that he would come to marketing after some suitable experience in other areas. I think he joined marketing in about 1966. So he was in my marketing group for only a short time before I transferred to HPA to work on light emitting diodes.

I remember Ned as another John Young and Doug Chance, all cut from the same mold; analytical, bright, easy to work with. He, too, was very effective in product strategy work, which was where most of our new MBAs got assigned. It gave them a chance to virtually run their own "company" by managing a product line of maybe \$20 million dollars. They created the future product strategies, defended the line against competition, devised the marketing and introduction plans, did the pricing analyses, created the training for field operations, and generally expanded their market share. All their work was done within the strength of a large, dominant merchant supplier of test equipment.

After several years in MWD as product marketing manager,

Ned was promoted to Marketing Manager of the Santa Clara Division. This entailed a rather dramatic shift of the type of products and customers. I used to jokingly call financial managers the perfect "mercenaries," they were ready to pack up their process knowledge and move to another division, take up entirely new product lines, and use their past process experience to expand the new division. Marketing's MBAs tended to be just as mobile.

In the late 1980s, the Stanford Park Division was again ready to split and move out some products, in this case, products with frequency ranges below 1000 MHz. That included the booming cellular and mobile communications market, and the specialized test sets and automated comms test systems that SPD had introduced. The decision was made to move the new communications division out to the eastern edge of Washington, to Spokane. Ned was promoted to General Manager of the Spokane Division and spent five years there bringing the HP culture to that remote location. In five years, when he left in 1985, the division had grown to 1000 employees.

The challenges entailed in moving a division to a new city for managers like Barnholt and Chance were often overlooked, I think. This was MUCH MORE than just hiring people and calming the city fathers when they foresaw a huge impact of traffic and "carpet-baggers" who didn't understand the cultures of their city. It involved a lot of community relations, serving on civic committees, Chamber of Commerce activities, and all of that associated work.

I later watched Ned's progress during those years when he returned from Spokane to take on increasingly important central management of the Test and Measurement part of HP. And then I was particularly proud to see how he took control of the massive job of spinning off the Agilent Technologies segment of test and measurement when HP management decided that the company's product lines must be split. The huge effort required to divide a company of almost \$8 billion revenues and a culture that was bound together was enormous. Just imagine all the considerations of financial, assets, human resources, employees, IT, systems, inventories, and a dozen other issues.

Ned took over as CEO less than one year before the crisis of the dot.com economic bust, soon finding that the Agilent company was saddled with WAY TOO MANY people. His true management skills came out at the launch of Agilent which came at a time when the company found itself with a HUGE backlog of orders. These resulted from a breakout in two robust market and technology sectors. For the wireless communications sector the cellular revolution was sweeping the land.

The equally-robust and booming fiber-optic business was driving that industry to lay fiber all over the US and under the oceans. Regretfully, much of that capacity turned out to be something called "black fiber," meaning that maybe 90% of all of it installed was never connected on due to a staggering over-capacity. I recall the times when Agilent was struggling under order backlogs of 6-9 months, with customers crying for deliveries, and our divisions working desperately to ramp up production.

Alas, it all collapsed into dust when the dot.com economic burst and orders went away, with many divisions discovering that customers had been double and triple ordering to assure that their deliver quotes would be met. Those ordering tricks previously had been only seen in the semi-conductor parts business.

So when the bust came, not only did current orders stop, but large amounts of previous orders were cancelled or abandoned. Thus a company must deal with a huge amount of over capacity in production and people. The retrenchments at Agilent were wrenching, layoffs personally devastating, and the attempts to keep Agilent from financial disaster certainly stressed all the fine objectives and cultures of Dave and Bill. Thousands of loyal employees were released, top management was put to the test.

I believe that Ned handled all that business turmoil about as well as anyone I know could have done. He kept a certain humanity and rational approach to the problems. He made strategic decisions on product lines and facilities well. I found a good reference to Ned's own reminiscences in the Barnholt oral history taken for the magazine Computerworld Honors program, and available on the Internet.

Ross Snyder

I missed Ross in my HP personalities chapter of the early revisions of this narrative, as I missed a number of other people and their stories. But in the two-year interim, as I have gotten literally dozens of comments and suggestions plus a few corrections, I discovered a bit more to qualify Ross for an interesting character of HP history.

In the 60's, the product division's marketing staffs worked through central groups in the corporate offices to accomplish our product advertising and technical publicity objectives. All of our new product and technical applications output was funneled through a professional PR wordsmith, Ross Snyder. As divisional contacts, Dean Abramson and myself had a long working experience with Ross, and we always found him the consummate PR man.

Ross had previously worked at Ampex Corp in Redwood City during its post WWII days of great product innovation. These were the years of the early video recorders that created a huge new paradigm in broadcast television. I recall that one of our technical seminar lectures during my 1957 Stanford master's program was given by the project manager from Ampex whose group had just introduced the new video recording machine, using cross-scan and 2-inch wide tape.

At HP, Ross was a workhorse of publicity output. His demeanor was self-effacing, almost to a fault. We who knew him well, always thought that he never took enough credit for superb word-smithing of our PR output. The procedure was that the divisions would write the product or application release, then Ross would edit or re-write as needed. His abilities for professional composition were legend. And in his personal presentation, he was the gentlemen's gentleman. His relations with the global trade magazine editors were the highest, and you could tell it when watching such interactions at places like trade shows or conferences. The editors all

respected him, and in turn, HP and further in turn, our divisions and products.

Ross made us all proud of our connections with HP. When editors visited the HP factory in Palo Alto, since there were only a couple of manufacturing divisions left in town, we in the Microwave Division would often get called to give a factory tour for the visitor. In all the 25 years that I knew Ross professionally at HP, I never knew his real background, until long after he retired from HP in about 1985.

His history came out about 2004, when I contacted him to report on the medical condition of an old associate of his, Harry Lewenstein. Harry had worked with all of us at HP, but had ended paraplegic due to a bike accident in Portugal in the early 2000s. In the process I visited Ross at his home in Woodside, where he was aging gracefully, with the usual medical infirmities. It should be noted that in his prime, Ross enjoyed gourmet food, fine restaurants, and boasted a huge wine cellar. In fact, he made annual treks to the wine region of France each Spring to re-stock his cellar.

In long conversations with Ross at his home, out came the stories of his work in WWII. This mild-mannered man, in all those decades I knew him, had never told anyone at HP that I was aware of, that he was an aircraft commander of a B-29 during WWII. He flew out of Guam on missions over Japan, and told stories that curled my hair. He accomplished 35 missions, earned 7 air medals, including 2 Distinguished Flying Crosses. What an amazing revelation! Most of those missions took place before the U.S. captured Okinawa at great human cost. That operation ensured close-in airstrips for the swarms of B-29s that were clobbering Japan's industry night and day.

Missions from Guam were 14 hours long. If you lost one of your 4 engines, your return to base was problematical. And losing 2 was personal disaster dunking into the Pacific. Bomb loads and fuel calculations were tricky. Ross bragged about his flight engineer who could nurse those 4 Wright 3350 engines at full power when needed or be miserly on fuel when that was low. They were not very reliable. Hundreds of aircraft took part in those daily raids.

One interesting sidelight was a story Ross told of requesting a gallon of silver polish from one of his friends in the states. He put his ground crew to work on polishing the aluminum of the whole fuselage and wing's structures. The upshot was that his aircraft flew about 10 knots faster, which apparently made just enough of a speed difference in their bomb runs that it upset the mechanical calculations of the anti-aircraft gunners in Japan. He thinks it had something to do with their better survivability. It also gave them increased margin in fuel management for those long flight times.

But, you can guess that I was just stunned to find out the untold history of Ross. Never in a thousand years would I have guessed this brave man's contributions to WWII. Even Dave Kirby, who was Ross's direct supervisor for a decade told me that HE didn't know of Ross's WWII history. The website for the USAF B-29 groups that flew over Japan show all these young men, under their crushed officer hats, grouped under their aircraft. So many never came home. It was a

statistical thing, you flew knowing the odds each mission and each day.

In the immediate post WWII, I can recall flying the 4-engine Lockheed Constellations or the DC-4s or DC-6s for cross-country trips before jets. They roared and vibrated and at the end of an 8 hour cross-country flight, you were just as fatigued as if you ran 20 miles. Imagine doing that day after day, with the very real danger of dying in the ocean, with no possibility of rescue.

I salute all those intrepid airmen of WWII, who were mostly like Ross, silent about their accomplishments in the face of personal danger.

About a year ago, I asked Ross to join me on a day trip to Castle AFB in Merced, because I wanted him to walk with me around the aircraft museum and share some of his experiences. The base is closed now, but there are still about 50 of those old warbirds on display, from WWII bombers, freighters and fighters to the B-36, 47 and 52. There is even a nasty looking SR-71, displayed out front. We started with the B-17 which he had trained in, it had engines made by one of the two major manufacturers, Pratt-Whitney I think, but those engines were "bulletproof" and never stopped running.

As he stood by the B-29, he recalled their continuous problems with those 3800 hp Curtiss-Wright R-3350 engines, 2 ranks of cylinders, and a lot of parts made of magnesium, not the best material for fire. The superchargers were unreliable yet they had to be used at high altitude. The B-29 featured a new K-band radar which allowed them to fly high and bomb with modestly good precision through bad weather.

It was a day I will never forget.
Ross died on New Years Day, 2008.

Cathi Merigold

For decades, HP management was a bastion of white, male, engineers. In the 1970's, serious attempts were made to widen the reach for women engineers, using our huge college recruiting efforts. Women engineers were always hard to find, but they were there, if you tried hard enough.

Cathi joined Stanford Park Division marketing, in the mid-1970's. She was a bright, energetic individual, who came to be interested in recruiting more women engineers. The microwave arena was a mostly male redoubt, partly because it was an OLD division, with mostly-older engineers, left over from the founding of that charter division in 1962. Due to outside pressure, the R&D lab had worked for some years, to increase their content of women engineers, and had gotten the count up to about 6.

After a few years of exemplary work, Cathi was selected to transfer to the European Marketing Center in Amsterdam, to promote the microwave product line. After about 3-4 years of excellent performance there, with good reports from abroad, Cathi rejoined the SPD marketing. But, to her dismay, she found on her return that ALL SIX of the women engineers in the lab had left the division, some transferred to other HP positions, and the rest had left the company.

Cathi felt strongly enough about that news, to actually take her own time to track down and interview all 6 of the women who left. What she found was not pretty, they all complained of an obvious lack of concern in R&D management, as well as other staff members, to take women engineers seriously. For some, the management environment was on its way to being hostile. So Cathi assembled the information, and asked for a meeting of the division management team, to present her interview data. It showed that something was clearly wrong.

The upshot of the response was that the division realized that, although all newly-hired engineers, women and men, were assigned a personal mentor, it seemed that women engineers approaching the RF/microwave technology were at a disadvantage. This turned out to be true because most of them didn't have the personal experience of young men. Men were more comfortable with fixing an auto engine, or soldering up a home audio system, or home shop activities. And, since a lot of microwave involved mechanical fixtures and fabrication, the women were considered, by other peers, as being behind in mechanical skills.

The result was a novel program, whereby all new engineers were assigned two mentors, a personal one and a technical mentor. In this way, the new hire could follow the senior engineer around for a couple weeks, and see the activities needed, in the model shop, in the production area, and actually get their hands on a soldering iron, and a drill press. The new program seemed to help, and soon there were more women joining the MWD. However, to be honest, women engineers made far better progress in other areas of the corporation, computers and printers and other more consumer product areas.

A more sobering story. It was probably the late 1980's, when Division Manager Alan Seeley called an offsite management meeting for Half Moon Bay, for about 50 of the top and first line supervisors of the Stanford Park Division. As the meeting drew to a close on the second day, Al got up to summarize, and at the end asked if there were any subjects we missed. I got up and observed, by looking around, that in that whole room of 50, there were only 4 women. So I suggested that Al give an assignment to every functional manager, to take home an action item, that next year, he hire, mentor, promote, and bring with him one more woman manager or supervisor. That way, next year, we would have 9 women in the group meeting.

Al hesitated a bit, said something innocuous, and called for a coffee break. I moved over to the coffee table, and was joined by a few of the senior lab engineers, who promptly dropped the ceiling on me. "How dare you suggest that we set some sort of quota on their lab? Don't you realize that no one moves up in this organization, without earning it?" It was very hostile, and I must say that I was overwhelmed, because all of these were personal friends, who I had worked with, for decades, in some cases. But the opinions were widespread. It was disconcerting. But, in reality, not really a surprise. It was my own dose of reality of the lab culture, which the SPD women engineers had to face every day.

Finally, another disappointment. I heard this first-hand

story from Gail Sweeny, another SPD woman marketing engineer. Gail had also transferred to the European Marketing Center, after a distinguished period in SPD marketing and production. During one of her new product training tours for one of our SPD instruments, in Scotland, she was presenting her talk to a crowd of about 50 FEs. At one point, she hesitated, and a comment from the back of the room shocked her, "Not bad for a woman!" Mild laughter. She proceeded, and again, a little later, the same comment. It became a running joke, but she finished finally to applause.

As soon as I heard the story, but several years later, I was furious. I immediately wrote the T&M Executive V.P. of the time, and encouraged him to find who was the senior HP official at that training session, give him a chance to defend himself, and then demote him. I felt that actions like a demotion were the only way to make a point, and once the word gets around of what happened, and HP's intolerance for such behavior, the sooner things would change. Everyone knew that European cultural values were not kind to women, especially technical ones. To my disappointment, that V.P. never took any action, and I regret now that I didn't take the matter up higher in management.

I believe that later decades of HP found a more open atmosphere for women, although, in looking through the management ranks, even today, it is a disappointment to me. My observation has always been that I have seen what can happen when functional managers are given tough assignments. If an aggressive assignment was given, to add one woman manager per year, no excuses, believe me they would find a way to identify outstanding women, recruit and mentor them, and make them successful.

I am sorry I never had more management authority, because I would have put in more goals on results, no excuses. And I don't think that men's rights or opportunities would have been violated. It is just true, even today, that the high-tech business, from venture capital to the most far-out scientific research, is the domain of men. I believe this is because young woman are not recruited into science and math courses, in high schools. I do also believe that there is still something genetic in men, which makes such technology life work more interesting and challenging. Not for all men, and surely not for all women, which is why identifying and mentoring and recruiting of women is so vital.

Russ Riley

Russ was a brilliant engineer. He was one of the quietest men in the lab, but that just belied his analytic power. Russ became the "technical stress interviewer" on the factory recruiting teams, which hosted the day-long visits by college seniors, who came to the plants. His style was so subtle, that he never caused the candidates to worry, yet the team got a solid idea of how these young students would attack an unstructured problem. The theory was that you didn't have to compute an immediate answer to certain technical questions, but by asking the question in certain ways, you could determine the mental approach the student would use and that was often crucial to their later success.

Russ was also a committed audiophile. The San Francisco Symphony had a strict rule that NO tape recorders were allowed on the floor, during a performance, Russ constructed a recording system, with superior audio performance, but using a standard tape system, which he enhanced for higher frequencies and stereo. This could be carried in his suit coat. He found some high-performance microphones, which he arranged to hide inside his long hair, and carried behind his ears, which produced enough stereo separation to give good results.

The system worked, although I don't know how many times he used it, since at least I would have found it confining, to have to hold my head fairly stationary during the concert's music-on times. Russ allowed me to listen to his headphones of a performance, and I was blown away with the crispness and the stereo capabilities. It was just like being there in the front rows of the actual concert.

Russ was the kind of man who would always make himself available for less-intellectual engineers like myself. I could always count on him to offer half an hour, if I needed it for some sort of technical problem. He was more than a mentor, because he would usually derive the answer, starting from simpler principles, and that was always impressive. Russ also had a playful streak. When their area of the engineering lab got too hot during the winter, the engineers were not permitted to adjust the thermostat. In fact, it was sealed shut. Russ's solution to that was simple. He hung an adjustable-heat generating resistor just under the temperature sensing gadget, and the hot air made the thermostat think it was getting hotter, so called for cooler air for that section of the lab. I don't think the facilities guys ever caught on to this simple, but clever, gimmick.

••••••••

Inside Stories of Some Legendary HP Products

I have assembled some short stories about some interesting HP's products, which I think have facts to be revealed about them, that weren't in the popular press. They are a little like Paul Harvey's "*The Rest of the Story*." In general, these were not HP's most important products in terms of revenue or profits, although some, like the HP 35 hand calculator, were. But they do show the diversity of creative ideas, which surfaced among all those HP individuals, who were looking for customer needs to be solved. And they often reveal some very real human conflicts, in justifying and proceeding with research, when others didn't support it.

In one of our management meetings, Bill Hewlett was discussing how to determine just how much risk we should take, when justifying a new product R&D project. His guidance was that if you didn't have some failures, then you weren't being venturesome enough. I remember him saying that he definitely did want some failures. The other general guidance we used, for some years, was that HP wanted to stay in the technology business, with products adjacent to our normal product line, or which fit into our marketing organization or customer base. This began to change, once the desktop computers and printers and other acquisitions like medical electronics, came along.

In most cases, I've listed a technical reference to the *HP Journal* issue which featured the product. The *HP Journal* was the company's pre-eminent technology communications tool, used to explain and promote new products to our mostly-engineer customer audience. This product listing sequence is not in chronological order of introduction, nor even in my view of product importance.

HP 200CD Audio Oscillator

HP Journal, Dec, 1952

Everyone knows that Bill Hewlett invented the HP 200A audio oscillator, the instrument that launched the company. But few know that it had an upper frequency limit of only 20 kHz, when first invented. The lab had improved the range up to about 50 kHz, and then ran into circuit parasitic problems, and left it there.

Enter Barney Oliver, returning from years of research at Bell Telephone Labs, in New Jersey. Barney was a classmate of Dave and Bill at Stanford, and was talked into joining HP in the late 1940's. Barney had a way of looking at problems that was unique. His first look at the circuits of the HP 200 convinced him that simply by going to a balanced circuit configuration, he could get well-over a 10 to 1 improvement in the frequency coverage. They tried it, and it worked, to 600 kHz, the first of hundreds of contributions that Barney would make to this company, over a 40 year career.

I recently ran into an interesting retrospective article on the status of HP's main audio oscillator competitor, in 1939. The company was the General Radio Company, of Cambridge, MA. H.H. Scott was later to gain fame and success as a pre-eminent manufacturer of audio systems, and worked at GR before starting his own company.

"In 1937, Scott applied for a pair of patents, covering the application of frequency-selective feedback networks to audio oscillators and amplifiers. One patent covered the resistance-capacitance oscillator, that was destined to completely supercede their older designs, and should have let GR dominate the market for years to come."

"But, for several reasons this did not happen. GR's credo was performance first, price second, sometimes regardless of its customers' wants. In the 1930's, the Beat Frequency Oscillator was a better design, and GR had several models available; Scott, in fact, had helped to design them. In the beat frequency oscillator, two RF signals, one fixed and the other variable, were mixed together to produce the output frequency. This arrangement permitted a wide tuning range, without band-switching. . . . General Radio now licensed a couple of college kids from California, William Hewlett and David Packard, to use Scott's patent. Hewlett and Packard had been casting about for products that might be manufactured by their newly-formed firm."

"Hewlett was working for his master's degree with a small group of students studying various uses for feedback in amplifiers. Their mentor was the distinguished radio engineer, Frederick Terman. Hewlett's contribution was a feedback oscillator, stabilized by a nonlinear resistance (a tungsten-filament lamp) in one arm of the Wein bridge.

Tungsten lamps had been used a year before, in a crystal oscillator by a Bell Labs researcher, and of course, the Wein bridge was not new. But Hewlett was first to bring all elements together in a practical RC circuit. . . ."

GR belatedly produced an RC oscillator in 1948—their model 1302A. But it was priced at \$365. Incidentally, although the unit used a Wein bridge and tungsten lamp, it was not licensed under Hewlett's patent."

From the GR Old Timer's Bulletin, May 1996, Alan Douglas, Pocasset, MA

HP 300A Wave Analyzer

(introduced 1941)

HP Journal, August, 1951

HP 302A Wave Analyzer

HP Journal, Sept, 1959

The HP 300A wave analyzer was perhaps the second instrument designed by Bill Hewlett, in 1941. It was a remarkable instrument, in a huge wooden cabinet, almost 3 feet high. It was essentially a tunable audio receiver, with variable IF bandwidth, achieved using control over a regeneration effect, as well as a degeneration effect—presumably using various feedback methods. But it was VERY sophisticated for 1941, when feedback theory was just coming into its own.

I well-remember my Notre Dame engineering laboratories in the late 40's. Standard instructions for preparing for one lab experiment, called for the experiment leader to come into the lab at dawn and turn on the HP 300A so that it could heat up for at least 4 to 5 hours, before any measurements were made. The alignment procedure for the selectivity adjustments in the IF strip bandwidth, and LO were super-critical. The drift of the vacuum tubes would make all data useless if this alignment procedure were not followed rigorously. It took almost two decades to replace the HP 300A. It is an interesting coincidence, that HP's second transistorized product was the HP 302A Audio Wave Analyzer in 1959. That machine was a wonder.

Having used such a problematic instrument like the HP 300A, the HP 302A was nothing less than miraculous. No drift. It had constant tunable selectivity. It even had automatic frequency control, for locking onto a slowly drifting signal.

Dick Rucker relates that Dave Cochran (BART & HP-35 stories) was, in a small way, legendary before he got famous for his HP-35 algorithm work. He worked part-time, nights Dick thought, in the Test Department on HP 300As -- the old original wave analyzer -- while at Stanford, and he tested them faster and better than anybody. And it was reportedly a BEAR to test.

The HP 9100A Desktop Computer

HP Journal, Sept, 1968

The first HP desktop computer was introduced in 1968. Barney Oliver credits three people with the combined idea. Tom Osborne, designed a floating point calculator, while with his Logic Design Co, in Atlanta, GA, and brought the idea to

HP. Malcolm McMillan had invented a mathematical algorithm and calculator for transcendental functions. Paul Stoft, and his group in HP Labs, saw the future of such a combined machine for engineering and other uses. In that era, we should remember, that clickety-clack teletype terminals were the accepted human interface, for time-share computers.

The HP 2100 mini-computer had been recently launched, with the purpose of controlling one instrument for each of 14 slide-in interface boards on the bottom cardcage. The new industry applications software language was called BASIC. Engineers were just beginning to anticipate the power of distributed computing, using small computers rather than a central big-daddy IBM mainframe. So the world was waiting for a scientific desktop machine.

Dave Cochran shared with me some insights on the initial history of how HP got into the desktop calculator (HP 9100) business. He was right in the middle of it at HPL. He told how two men had contacted HP with ideas. "1) Tom Osborne talked to Barney, with his balsa wood, floating-point calculator; and some neat logic, like switching the power to turn on a function, but it was only four-function. 2) About the same time Malcolm McMillan spoke to Hewlett about a spin-off of the navigation computer in the B-58 Hustler bomber that could do transcendental functions, but was only fixed point. It was derived from a paper on pseudo division by Meggitt of IBM in 1962." For an interesting insight into how Osborne built a computer without any test equipment, see the Reference Section at the end for his interview with Steve Leibson.

"Barney and Hewlett compared notes, and Barney called a bunch of us together to see if we could marry the two concepts, with Osborne's help. We decided we could put McMillan's algorithms in Osborne's floating-point architecture. Barney asked, 'Who's going to do the algorithms?' I answered, 'What's an algorithm?' Barney said, 'Well Dave, you're going to find out.' Gee, I should have learned about volunteering from my stint in the military."

Cochran observed that he found out in his first investigations, that algorithms go way back. "The word comes from the village of Kurizimi, where there was a 9th century Arab mathematician named Jabar and "al" means "of the." I found some of the early transcendental function routines while doing some prior art work for legal back-grounding, and what we used was described by Henry Briggs in a treatise in Latin in 1624."

Cochran continued, "During the development of the HP 9100 desktop Hewlett had always talked about how it should fit in the typewriter slot in his desk. Well, when we fished the first prototype, someone remembered Hewlett's wishes so we trooped over to his office to check it out. Darn, it didn't fit, but Hewlett was out of town so we called Johnny Harrison at the carpenter shop. By the time Hewlett came back he had a HP 9100 Calculator in his "modified" desk." Bill said, "I knew you guys could do it."

One must also remember that integrated circuits were still a few years from reality. Thus, the Read-Only-Memory (ROM) for the HP 9100A, was constructed out of a 16-layer printed

circuit board, with 31,000 bits (diodes) and transistors. The display was a CRT, so that the four-stack registers could all be displayed. And this was HP's first roll-out of reverse-Polish notation (RPN), a preferred number notation for scientific computations. The sales price was a remarkable wonder too, \$4900.

The HP 9100A caught the imagination of the engineering community. I believe one of the first units was given to Arthur Clarke, the acclaimed science fiction writer. The project development was done at HP Labs in Palo Alto, and transferred to Loveland Division, Colorado, for production. This product probably became the first HP product to experience large-scale production, compared to the usual HP electronic measuring instruments. And, without question, it launched HP into personal technical computation.

Cochran designed the algorithms, a monstrous job because of the stringent limits on memory size, and the need to make sure that all calculations were accurate over the enormous range of numerical "arguments." Barney later paid tribute to Dave's genius, "I sometimes wonder if Dave realizes what a remarkable job he did? It took several passes. On the first pass, it appeared hopeless to include all functions."

The HP 9100A led directly to the 1972 family of the HP 9810/20/30A programmable calculators (which would then be called desktop computers), which had full HP-IB automation capability

HP 35 Handheld Calculator

HP Journal, June, 1972

In a real sense, the idea for the HP 35 handheld calculator came from a number of sources. Certainly the HP 9100A desktop computer, of 1968, showed the popularity and power of a desktop, technical (personal, not depending on a time-shared mainframe) computer in the hands of engineers. Transistorized desktop adding machines were beginning to take the place of the clacking mechanical "comptometers," built by business machine suppliers like Friden Corp., and others. Japan was building desktop calculators for business use, with Nixie tubes for display. Light-emitting-diode numeric displays had barely been invented.

Time for a handheld concept. At the HPA (components) Division, in early 1970, we had just concluded technical negotiations, for supplying keyboard and digital display light-emitting-diodes (LEDS), with a company called Unidynamics of Phoenix, AZ. And yet, after some months of research and production planning, the company, a division of Universal Match Corp., had decided not to proceed toward building a commercial pocket calculator. The main reason was that their core business was production of super-high-tech electronic sub-assemblies for atomic weapons. Their management had concluded that they should not move into the purely-commercial sector.

But, in retrospect, they had the hand calculator product concept, dead on. They had envisioned a handheld calculator, the size of a king-size pack of cigarettes. It had a 6-digit display, mounted horizontally, and four functions of add, subtract, multiply and divide (what we termed a four-banger).

Further, they ingeniously had planned two or four more math functions, to be built into the ROM. These had keys that were to be covered up in the first models, but which could be uncovered, as needed, to confront competition, without having to re-design anything inside, merely put a new faceplate on the front.

The reason Unidynamics had come to HPA, was that we had a first-class ceramic facility for building photo-conductors. Photo-conductors were used for the electronic counters, built by the Santa Clara Division, to decode the BCD logic of counting circuits, into the 10-line code needed to drive NIXIE numeric display indicators. Unidynamics envisioned the need for a cheap keyboard, while at the same time, they needed long-life reliability. A photo-conductor keyboard, with no moving parts, seemed ideal.

Their idea was to use a photo-conductor resistive element at each key location. They had built prototypes, which demonstrated that when a finger was pressed into a shaped depression "key," the photo-resistance would change by about 1 million to 1. They had tested pulse-shaping processing circuitry, to eliminate false key inputs, caused, for example, by shadows of moving fingers across the panel, or variations in ambient lighting.

Unidynamics had done their homework. They had hired an experienced consumer-marketing man from 3M Corporation, who became their V.P. of Marketing. He had lined up international distribution for the product to the tune of 10,000 units per month. The price was to be \$200, at the time that Japan's Sanyo Corp. was selling a calculator that was the size of a small cigar box for \$400. Japan's Canon was moving to a "pocket" calculator, but it had to be a coat pocket because it was the size of a small book. Their price was projected to be about \$250.

In other ways, too, Unidynamics was ahead of their time. They envisioned 4 integrated circuits mounted on the rear of the ceramic "mother-board" which carried the key photo-resistors and display on the front. Production would be so certain, that they planned no re-work, because of the expense, and therefore, would simply throw away bad units .

George Klock was project leader, and visited a number of times, along with Philip Tai, who was project engineer. Naturally, as soon as we in the LED group heard about this large project for keyboards, we immediately began our campaign to change their plan, for displays, to LEDs. We proposed either monolithic numeric chips (later used in the HP 35), or an abbreviated 3 x 5 dot matrix. That deal looked like a huge amount of business. They bought into the LED idea, and there were more visits with Tai, to work out the "LED strobing" technique, which we were just perfecting for use in HP 5300 portable counters .

Suddenly, and without warning, Unidynamics called us with the information that they were suspending their project. Amazing. They had the product concept in their grasp. They were about a year ahead of the market. They would have blown the market away. That year, 1970, Japan built about 150,000 total calculators, desktops, "portables" and "handhelds." The 10,000 per month sales estimate of Klock,

for \$200 units, was probably low by a factor of 5 or 10.

Once we had confirmed that the project was clearly cancelled, we felt we were released from our self-imposed HPA rules, about revealing any sales or technical details to other HP entities. We always held such information strictly confidential during our contract periods. In the components business, such technical and business details were sacrosanct. If another HP entity should discover any such details about a competitor who was our customer, we would lose all our credibility.

Then, and only then, it was HP's turn. I then fed back to HP Labs, an overview of the proposed Unidynamics calculator. My memo below mentions that I had just read a speech transcript, by President John Young, that the present HP technology would now permit HP to put the ROM of the HP 9100A desktop calculator into four chips of integrated circuits. That was amazingly close to the Unidynamics four chips, although the HP chips were a full engineering algorithm set. Talk about serendipity.

January 27, 1970

From: John Minck

To: Marco Negrete
Tom Kelley
Milt Liebhaber
John Nebozuk
Volkmar Schaldach
Paul Stoft

Subject: ELECTRONIC SLIDE RULE

Marco, I thought I would pass along a little information for what it's worth in considering a small, portable pocket slide rule or pocket calculator for HP.

We've had some recent negotiations with a U.S. company regarding both a digital display and a photoconductor keyboard application that looks like very large numbers. These people are talking about 10,000 units per month, minimum, with the possibilities for two or three times that in a few years.

While the particular company's name involved is not too significant, (in fact we probably shouldn't talk about them by name, since they have given us some information that was relatively private) I do think the overall market data and some of the particular components that we have are things that Hewlett Packard should consider. The particular product envisioned would be about the size of a pack of filter cigarettes, turned sideways, with an 8 or 10 digit light emitting diode cluster in the upper left hand corner. These would be about 0.1" in height and meant for viewing within arm's length. The keyboard would be

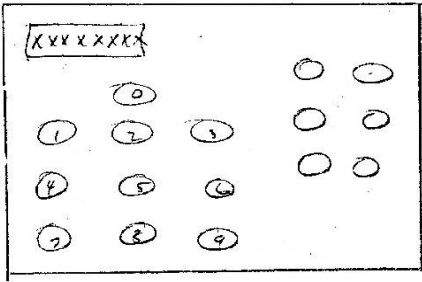

made up out of a photoconductor matrix for which HPA has already furnished samples. The computation will be done by a few, and I'm not sure how many, MOS integrated circuit chips done with LSI. I'm not sure who is doing their design but I do think that TI is involved. There are the normal numeral entry keys as well as a series of functional keys on the right hand side. We know nothing about the particular functions involved.

These people have already lined up an international distributor who has guaranteed to take 10,000 units per month and the proposed selling price is in the \$300 range. Although these particular people are neophytes in the calculator business, they do plan to get knowledgeable people in their production and it appears that they will be going toward some state of the art interconnection techniques so that they can do assembly at very low cost. They would plan to have very few rejects at the end and would essentially do no testing, but instead would just scrap the completed package if it doesn't work. That's fairly revolutionary by itself. They might be able to make it work.

The main reason I'm writing however, is to inform you of several specific HPA components that might be well-suited to getting Hewlett Packard started on some kind of a project like this. The first of these is a multiple cluster, strobed array, built out of 7 segment numerals, which we plan to have ready in about August of 1970. The product ideal is to "monolithically" produce the characters about .1" high and arrange them so that they can be strobed or scanned horizontally. We plan to produce these in various length, specialized clusters so they can be used for such things as pocket calculators, portable thermometers and a wide range of other numeric-only readouts. There are also some interesting possibilities of making characters even smaller than 0.1" and using plastic magnifiers of various types so we can get the power drain down even more.

Number two component is a photoconductor array that serves as a keyboard input. This is presently being made in John Nebozuk's area and has been specifically selected for the other company's calculator. They looked through a whole series of different keyboard entry ideas and rejected a lot of them because of contact bounce, reliability and just plain cost. It turns out that they have done a substantial amount of work in adapting the HPA photoconductor to use as a keyboard.

I think this is where Hewlett Packard needs to find some division with a keyboard need to pick up the present component. The other company puts a plastic mask over the top with holes cut in it about the size of thumbtacks that are appropriately shaped and spaced off of the photoconductor

element. The finger that is tapped across the keyboard, much like an adding machine, will go through the pulse shaping circuitry in the right fashion to energize the integrated circuit drive. On the other hand, fingers just moved across the keyboard in front of a bright light or placed gently on the "key" do not have the right closing rate to cause false entries.

According to the engineers, one of the main reasons that photoconductors are quite good, is because they have a very wide range of resistance change, approximately one million. They have designed their key covers and shaping circuitry such that a substantially less change of light causes the triggering. That allows them to work from a very low level illuminated room out into direct sun light without having false triggers.

I'm particularly excited about this keyboard because it could represent an important reliable component for Hewlett Packard Company and all the variety of keyboard inputs that we are ultimately going to have to have. I would like to find some project that could develop some further human factors work on the key entry. It would also seem to be important to have some sort of audible/ mechanical feedback to tell the person that he has made an entry. In the case of a calculator, however, it appears that entering data onto the little light emitting display itself becomes the assurance element.

When John Young recently mentioned that you had been able to put the entire 9100 onto four MOS chips, it really got me to thinking that an exciting product could be put together from that technology and a couple of display and key entry technologies. A pocket calculator that can do slide rule functions and some additional arithmetic functions and ought to be worth \$500 to many technical people.

I hope that sometime when you're in the area you might be able to stop by and perhaps we could discuss it in more detail. In any event, I'd appreciate knowing your thoughts on this general market area, and specifically whether light emitting displays and other keyboard elements might have some place in your product plans.

JLM:lb

cc: Barney Oliver
Dave Weindorf
John Young

Displays ideal for the HP-35. By that time, our HPA monolithic display chip technology could present a numeric digit, 1/10 inch high, and we could build them reliably. The HP 9100A project team had been pretty-well held together after transfer of the project to production to Loveland. Engineering for the HP 35 got rolling strongly in 1970, encouraged by both Bill Hewlett and Barney Oliver, who became the cheerleaders.

Think about the possibilities. With the ability to create dozens of calculation functions, the team leaned towards Electrical Engineering functions. 35 keys maximum resulted from a product design mandate, that the calculator must slide into

Bill Hewlett's shirt pocket. But the power of the machine called for up to 15 digits of numeric display. Barney was leaning toward liquid crystal displays (LCDs), but we, in HPA's LED department were pressing for LEDs, naturally. LCDs were dramatically cheaper, and only for the fact that LCD technology couldn't put 15 digits side by side, did we get the nod on the LED display decision.

In the meantime, we, at HPA, had perfected the use of a simple spherical plastic lens to magnify the 0.10-inch high character. It caused a minor reading drawback, which we called the egg-crate effect. This meant that the user had to place their eye more or less directly in front of the numbers. Otherwise the display would look like the numbers were down inside the partitions of an egg carton. But the fact that a 1/10th inch monolithic number only used about half the drive power as a 1/8th inch high unit, the designers preferred more battery life to larger numbers. It was still a hit, and never, ever, mentioned as a drawback.

In retrospect, the LED decision was very fortunate, for although the LCD technology had been around for 50 years, they were notoriously unreliable during those years. A LCD display set could develop an "infection," on one corner, and it would creep across the whole window, and you'd be out of the display business. Infection is the right word, since LCDs are organic materials. Now, 20-30 years later, things are different, and LCDs are everywhere.

Tom Whitney, HP 35 project leader, decided they could pay \$1.05 for each monolithic digit. Our HPA production costs, at the time, showed that we should sell them internally for about \$5.00 each. So we figured that with Bill Hewlett behind this project, so strongly, now was the time for a gigantic leap ahead in HPA's LED manufacturing automation.

Our team then developed a Gallium-Arsenide-Phosphide process lab expansion plan, which promised to be the biggest thing we had ever done. Until that time, we would slave over a \$30K process machinery capital investment proposal. The proposal might run 20 pages, and still not be accepted. These equipments weren't cheap. Epitaxial reactors for growing layers of semiconductor atoms, diffusion furnaces, saws, polishers, dicers, thin-film deposition, photo-resist stations, automated probing stations, ran to tens of thousands of dollars. Our plan for ramping up calculator digits looked like about \$550K.

Sales projections for the HP 35 were interesting. With the outside market, in 1972, expecting to feature four-function machines at around \$200 to 250, no one really was confident about how many people would plunk down \$495 (the first price proposed for the HP 35) for a pocket slide-rule. Even at \$395, the final introduction price, I recall the sales estimate as 500 per month and going to 1000 per month, on the outside.

At the LED department, fortunately, Marketing Manager Milt Liebhaber and Rick Kniss, the LED Product Marketing Engineer, had big plans for outside sales of LED digits, that would leverage on the production of the HP 35. We were sitting around one evening with the thick equipment proposal in front of a group of us, presided over by Division Manager Dave Weindorf. After much discussion, Dave suddenly said,

"What the hell, let's make it a proposal for a cool three-quarters million".

So we corrected the equipment lists, to get up to \$750K, and went up to see Bill Hewlett the next day. We had our arguments well honed and practiced, for proving the need for supporting the all-important HP 35, with incidental outside sales thrown in. After 5 minutes of preliminaries, presenting our executive summary, Bill stopped us, saying, "I've got another meeting, so is there anything else important, that I should know? If not, let's go with it." We almost wanted to say, "But, Bill, we have all this backup argument material, don't you want to hear it?" It was by far the easiest project I have ever seen sold. But it shows the magic of that calculator project in those days.

In retrospect, it was extremely lucky we sandbagged Bill on the materials processing lab for GaAsP. The 500-1000 per month forecast for the HP 35 was wildly wrong, on the low side. Sales went through 10,000 per month, climbing almost straight up. The reasons, of course, are clear with hindsight. The price was a stroke of genius, because the \$395 was easily within the reach of every engineer, not just managers. It was not only a prestigious personal possession, but an amazing drudgery beater. It made better engineers, and it made them faster and more efficient.

Pick a keyboard layout. Meantime, Tom Whitney was having trouble freezing the keyboard design. With literally hundreds of different key functions one could choose, Barney and Bill were continually coming up with better ideas for key functions and layout. Tom had finally arrived at a crucial date, where the IC ROM masks had to be frozen, to be sent to the IC vendors, and be ready for production dates. Tom sent out a memo to all the algorithm people, Dave Cochran, Bill and Barney. The notice stated that he had reserved the meeting room for as long as it took, that day, to freeze the keyboard functions to everyone's satisfaction. At the end of the meeting, all would sign the final keyboard paper, and he would walk out to call the IC manufacturer with the final specs.

The meeting did take a long time, hours. Back and forth, since this was to be the way the calculator would not only look, but perform. To all those engineers, with those options, it must have been excruciating. At the end of a long period, they agreed, and all signed the penciled-in key nomenclature. Tom thankfully walked back to his office, ready to prepare the material to call the IC supplier the next morning, and the phone was ringing. It was Barney. "I've got another idea." "Too late," said Tom, and he called Bill to see if he could make it stick. Bill said to go with the agreed paper.

The HP 35 introduction, in 1972, couldn't have come at a better economic time for HP. The US business economy was in the doldrums, and this high-profit product energized our balance sheet. The thing we had failed to comprehend, was that engineers would find this personal calculation powerhouse indispensable. They would not rely on their companies buying them, instead, parting with their own money to possess one.

Personal power. Tom Osborne, the project consultant, told

me of an occasion of his visiting the Smithsonian Institution in Washington, DC. He went to see the display of the original ENIAC computer, used in the WWII project for artillery-table computations. At the time, he was carrying the HP 35. He told me he was suddenly struck with the realization that, inside his coat pocket, in the HP 35, was more computing power than this entire roomful of equipment racks. The racks held 18,000 vacuum tubes, that burned out at the rate of about 5 per hour. Of course, it was an unfair technology comparison that spanned 2.5 dramatic technology decades. Tom was humbled to realize that his little baby computer in his pocket was more powerful, and certainly more reliable, than that monster system.

Field engineers found clever ways to sell HP 35s. Jim Bunn of the Las Cruces, NM sales office called on the U.S. Army's White Sands Proving Ground. He discovered that, while military operations sometimes ran out of expense or capital budgets, there was often a lot of training budget left, near the end of their fiscal year. Jim cleverly arranged to put on a training seminar for "*Reverse-Polish-Notation Scientific Computers*." It was an honest description for the HP 35. The special HP training course cost was set at \$500, and included an HP 35, as a class "training tool," which the student was allowed to keep.

Dave Cochran remembers, "Soon after that (the success of the HP 9100A), Hewlett began pestering me about putting the 9100 in his shirt pocket. Even several years later the right architecture for the state of IC miniaturization just wasn't there to accommodate what we wanted to do. I was even thinking of getting hold of Hewlett's tailor to get his pockets made bigger."

"I stumbled across an architecture during a visit to Fairchild that made it all gel. It contained a 'racetrack' register memory that greatly reduced the access and interconnection requirements and was excellently suited for the 'CORDIC' algorithm to calculate the transcendental functions."

"Fairchild was trying to make a twenty-digit four-function calculator but hadn't applied for a patent. In the next few weeks I roughed out architecture for arithmetic and logic chip, control and timing chip, register chip and ROM structure. I also devised an instruction set and flow-charted a few functions including subroutine calls."

"Excitedly, I went running off to Hewlett, 'Look, I can do it now, if you give me the million dollars for development.' Hewlett, who sometimes was unsure of himself without Packard who was at the Pentagon, said, 'Wait a minute, I want SRI to do a market analysis on this.' Four months later SRI said that if it was four-function it should be under \$100 but they could not supply a recommendation for a pocket scientific calculator because there had never been one."

"While waiting for Hewlett's decision we still went ahead on all fronts, I even devised a sampling scheme for the LED display that Minck mentioned that had the added benefit that it used only 10% of the calculated power due to the 'super linearity' of LEDs of the day. If you strobed each segment at a 1% duty cycle the current only went up by a factor of 10 for the same light output. I remember thinking that it may affect

the reliability so I ran a sample at 0.1% duty cycle and compared the light output after six months, luckily it was the same."

"I remember when Fred Terman got his sample HP 35, we made about six prototypes, he just couldn't believe it, kept looking for the cable. Louie Alvarez called it the 'eighth wonder of the world.' Having an HP 35 in the early days meant you could attract attention without having to know how to play the piano, but mostly you got all the men hanging around you at cocktail parties."

The battle of the algorithm gurus. The inherent power of these hand calculators was contained in their algorithms. These abstract mathematical flowcharts are really the processes the machine goes through, to solve the transcendental and other complex equations. Some people's brains are born with the power to envision these algorithms, in their total flow pattern, and somehow see through their complexity. One of these men was Dave Cochran. He created the heart of the HP 35, and probably has not gotten near enough credit for it in the outside world.

Dave told me that as other competitors came into the scientific calculator market, notably Bowmar and Texas Instruments, that he came to meet the algorithm inventors of those companies. They tended to be the same kind of genius-type people, clever and crafty. In one sense, it was a reputation thing, with each conceding points, if a particularly clever algorithm was being tested and qualified.

But in other ways, these geniuses were playing other games. It became a kind of chess game. They might tell about a new algorithm idea, but might salt-in traps and false leads, to put the other company on the wrong track for a time. Naturally, there were advantages to be gained in talking together since, often, it established industry standards and processes, and it was such an arcane art. Yet, all information had to be taken with huge caution. Did we gain more than we lost? Knowing Cochran, I suspect we gained a lot more.

The HP 35 was probably HP's number one product winner of its 6 business decades. It captivated our technical customers. It raised HP's already high prestige. It brought untold computing power to the fingertips of the common engineer, and they worshiped HP for the innovation. Finally, it sparked a long succession of more and more powerful machines, the magnetic-strip programmable HP 65, financial versions, and many more.

I personally believe that the HP 35 changed our HP history. It most certainly launched HP into the "consumer" market, even though this particular product had a professional (engineering/consumer) focus. HP later introduced other powerful consumer machines, some years before competitive \$10 units began showing up in drugstores. The line of successful pocket calculators also reinforced HP's dominance in desktop computer technologies, such as the follow-on HP 9810 and 9830, and later the highly-programmable HP 9826 and 9836.

In looking back on those heady days, I can recall one evening in the small office area we all shared, talking about how the

power of personal calculators would change our world. We were then immersed in a manufacturing technology where semiconductor packaging still required careful handling. IC chips were contained in separate plastic in-line packages and those dozen components had to be inserted into printed circuit boards for all the hundreds of interconnecting wires.

Our conversation got around to real visionary stuff, like attaching the IC chips directly to the PC board and bonding to the board. Then you could just squirt out a drop of plastic silicone to protect the whole thing from humidity, and sell the whole calculator in a drug store for \$10. Then we all laughed at our folly! However, knowing what I knew about the rapid decline in anything made of semiconductors, I did have the feeling that it just might happen someday.

Finally, there was a fascinating postscript to the Unidynamics story. In the 1980's, long after the 1970 negotiations for LEDs. I was back at Bldg 5, working on MW products at SPD Marcom. In those days, all customer inquiries sent to corporate headquarters in Bldg 3, were parceled out and sent to the appropriate division marketing people to answer as they had time. It was probably the late 80's, when a letter arrived from Australia, a teacher in a tech school had written to HP for some technical or product posters for his classrooms. The teacher's name was George Klock.

I gathered together a bunch of HP product posters and banners plus a frequency allocation chart and some other generic posters and sent them along. I also sent a note telling that years before I had known a George Klock from Unidynamics, and wondered if that were he? It was. After the calculator project was shut down, he migrated to Australia to start life anew, and ended up teaching, which he loved. Now, imagine the tiny statistical chance that I would pick up that particular letter out of a pile that just happened to be sent to our division. Another stunning coincidence of my life.

HP 721A Power Supply HP Journal, May, 1958

The honor for first transistorized product for HP, was the HP 721A Power Supply. It was a simple concept, a 30 vdc range and 150 ma capacity, with a clever current-limit feature. That safety feature was so critical to a generation of engineers that were just learning that transistors were not as forgiving to electric shorts and other mistakes as tubes. If a test circuit was misapplied, the HP 721A power supply would simply cut off its current to a safe level, that the engineer could dial in. I remember being surprised how many thousands of engineers would buy the product at an introduction price of \$145. For only 150 milliamps. But such was the rush to semiconductors of the day.

The circuit design was invented by Malcolm McWhorter and George Barr, both Stanford University professors. They went on to found the Vidar Company, using some of the royalties that were generated from this simple power supply idea. Malcolm McWhorter was my digital circuits professor at Stanford. In 1952, in my undergraduate days at Notre Dame, the transistor was described in mimeographed notes, having just been invented in 1948. So, I really needed to get re-treaded on digital circuit theory, when I hit my graduate

school study at Stanford. McWhorter's classroom style was magnificent, and he was perhaps my best technical professor. His explanations and circuit models remain with me today, although I often have to admit that I never really did an honest day of engineering in my life, preferring and enjoying marketing so much more.

The HP 8551/851A Microwave Spectrum Analyzer HP Journal, August, 1964

The frequency-domain oscilloscope. As mentioned earlier, this product put HP into a brand new microwave market area. We had been known for signal generators, power meters and swept-frequency testing before that. But the market for spectrum analyzers was owned by Polarad with about \$5 million annual revenue and Panoramic Corp., at about \$2 million. Spectrum analyzers had been designed for use with radars during WWII, and Polarad, located in New York City, had been a contractor for the government. Basically, a spectrum analyzer is a tuned super-heterodyne radio, with a swept-frequency or "panoramic" display, signal power plotted vertically against a horizontal scale of frequency.

HP launched into spectrum analyzers, partly driven by pressure from our Field Sales Engineers, who were looking for a new market area. The Polarad analyzers were mostly single-octave-band, hand-tunable klystrons, used as the first local oscillator. The sweeping 2nd local oscillator (LO) provided the 100 MHz sweep width (dispersion, in the jargon of the day). The Panoramic Company, also on Long Island, was soon building a multi-band unit, capable of 2 to 12 GHz, which down-converted using harmonics of the 1st LO.

The project engineer assigned to the HP analyzer was Art Fong, who had been recruited from the WWII MIT Radiation Lab. His experience there had involved building signal generators and specialized spectrum analyzers, including waveguide components. By designing a sweeping FIRST local oscillator, using a backward-wave-oscillator (BWO) for the source, it was possible to provide a remarkable 2000 MHz of sweep width. The key technology, needed in the use of the BWO, was the breakthrough use of a tracking, phase-locked, low-noise-VHF sweeping oscillator. The ability to track while phase-locked, quieted the phase-noise of the BWO tube, when in the narrow band sweep mode.

The HP unit was conceived to have a number of significantly higher-performance features, far wider sweeps, an honest and calibrated 60 dB of amplitude range. Yet, it was thus destined to cost much more. In my original market research, I had found that most customers would have been happy to have the same performance as Polarad, but just have a product brand from HP, with HP workmanship, features and reliability. But when we plotted the price-volume curves, the tail of the curve, as usual with most HP products, stretched flat, far to the right. Which simply meant that there would be considerable demand, even with prices that might be twice the available products, or in this case, some real demand even at \$15,000.

The HP 8551A Spectrum Analyzer was first demonstrated, privately, to customers during the 1963 IEEE show in New York. Project Engineers Art Fong, Harley Halverson (HP851

display), George Jung (HP 8551 RF section), and others, had finished a prototype, to bring to a hotel room, for showing to VIP customers. The unit was mounted on a draped table, but under the drape was a massive fan, blowing air up through a laundry dryer hose umbilical, to keep the parts cool. It took a lot of air to cool the high-voltage power supply, needed to run the backward-wave-oscillator, requiring 2400 volts.

A lesson in pricing strategy. Actually, the price was approved in a hotel room, too, a year later, just prior to the 1964 New York IEEE show. Marketing V.P. Noel Eldred, Division Manager Bruce Wholey and I met to agree on the price. I presented a price-volume plot to guide us on the product price. Largely an estimate, it showed that at prices of \$5K, where there were competitive offerings of less performance, the volume might be 50-100 per month. At \$10K price, the volume had dropped to 20 per month, but the volume line went almost flat from that point out to \$20-30K price, confirming that customers would pay a lot for our unique features.

Reflecting on Dave Packard's philosophy to price for value, Eldred didn't hesitate, and approved a price of \$9500. Imagine our surprise when, within the first year of production, the volume went past 75 a month. It soon became HP's first \$1 million-a-month product. An early lesson, I learned at that meeting, was that we continuously under-estimated the amount of money our engineer-customers were willing to pay for HP products, that have unique performance features.

It was Paul Ely's idea to position this product as a "Frequency-Domain-Oscilloscope." And it truly was just that, because it could sweep a baseband of 10 to 2000 MHz in a single display. This single instrument became the \$10 million grandfather to HP's entire Signal Analysis Division, and taught many fledgling engineers and marketeers some powerful lessons on product strategy, positioning, and marketing.

The rest of the story. Here are my sales forecasts for the Spectrum Analyzer, from the 1965 MWD market plan binder, which I recently found in some old boxes at home. I think I made the forecast in late 1963.

Year	Annual Sales (\$M)
1964	1.05
1965	2.85
1966	3.09
1967	2.85
1968	2.61
1969	2.38

Realizing that the annual revenue in 1965, generated from 75-100 units per month, was between \$8.5 and 11.4 million, the above sales forecast was woefully conservative. But, since the Microwave Division had been enduring a recession from 1962-64, with flat revenues of about \$20 million, we were extra cautious. Yet, the HP 8551A was one good reason we emerged from that recession faster than normal in 1965.

HP 524A Electronic Counter

HP Journal, Jan, 1951

As the nation recovered from WWII, the atomic energy

business was big time. Not only was nuclear research welcomed, but all sorts of other nuclear advances were predicted, from chemical to pharmaceuticals to medicine. Crucial to such developments was the measuring instrumentation that was needed for nuclear data. Pulse counting and energy profiling was one area that appealed to HP. The pulses, of course, were those derived from nucleus decay and detected by various crystalline sensors. The horsepower race of those days, was to build counters that count higher and higher rates of decay, and discriminate between two closely-separated radiation pulses, the closer the better.

Frequency counters. A fellowship grant made to Al Bagley, a young graduate student at Stanford University in 1948, led to the development of HP's frequency counter business. Hewlett and Packard personally asked student Bagley to study the measurement needs of the nuclear physics industry. From that study came requirements for a faster nuclear-pulse-counting technology, that could resolve two nuclear events, only 0.1 microsecond apart. Bagley determined that new, low-capacitance semiconductor diodes, just coming on the market might allow faster digital circuitry. He built a prototype as part of his project—and then asked for a job at HP.

Out of that work, came the HP 520A high speed decimal scaler, which was able to condition very short nuclear pulses, occurring at up to 10 MHz. It also divided down the count rate by factors of 10 or 100. Sadly, the 520A had only minimal commercial success. However, Hewlett envisioned a different measurement process, one that gated those scaled-down, high-speed pulses into a slower-speed accumulator (counter). It used a selectable time base, similar to that of the earlier WWII HP 100A time standard. Out of this combination was born the common frequency counter.

Those "combination" frequency counters were a huge commercial success, and in great demand from the 1950's onward. They were used in measuring everything from transmitter frequencies to the accelerometers on which ballistic missile guidance systems were based. HP became the industry leader in electronic counting, in the early 1950's, with the HP 524A frequency counter (ca. 1952), which boasted a 0.01 cps to 10 "mc" measuring range. (Hertz came a little later.)

In 1954, plug-in down-converters were added and introduced as the HP 524B electronic counter, which became an industry standard for some years. Plug-ins eventually measured to 18 GHz, after the introduction of the step-recovery-junction diode. Over the years, this product line generated massive revenues and profits, which funded untold numbers of new products.

The atomic Minck. My own introduction to the HP 524A, came in 1952, when I was out on Eniwetok Atoll, in the South Pacific. We were working on full-scale atom bomb testing, installing blast line instrumentation, which characterized the atmospheric blast effects. Eniwetok Atoll was about 30 miles across, with maybe 20 coral "islands" around the outside circle. It was the result of an old volcano, which rose out of the ocean bottom eons ago, and produced a beautiful blue lagoon in the center, and a surrounding string of islands, built

mostly of coral. Think of the atoll as a clock, with the shot island at the 12 o'clock position, and our task force civilian housing headquarters at 5 o'clock, while the military task force which supported everything, and including the "airport," was at 7 o'clock.

This "Mike" shot, on "Operation Ivy" was the first full-scale test of the fusion technology. The H-bomb was predicted to be 4 megatons of energy, and feature a fireball 4 miles in diameter. Needless to say, the instrumentation was housed in heavy-weight concrete bunkers, with a blast line running from the islands at 1 o'clock to 5 o'clock. We had set up about 9 bunkers in all, although the blast was so large that all 10,000 people in the task force were evacuated to ships, which stood off at least 40 miles to the south of the shot island on the day of the shot. By the way, I was intrigued to find a lot of historical information about this test, and many more, on the Internet. Just Google Operation Ivy.

The electromagnetic effects of atomic weapons were fierce, so timing and communication and power cables laid between islands were useless, and the instrument shelters were totally self-contained. In our case, we used about 100 auto batteries, in a separate ventilated battery room, which powered electric motor/generator converters, to get 115 volts. Therefore, we needed to install a highly accurate time standard into each shelter. This required that two days before the shot, two of us, in an Army helicopter, loaded an HP 524A aboard, and started a day-long excursion up the chain. At each island, we would carry that monster instrument through the sand, and into the bunker, let the counter warm up, and make a frequency check. Back through the sand, and onward. Needless to say, that was an exhausting day.

For a kid just out of college, arriving at an operation of such scale was a bit unnerving. My first trip up to the shot island was on a Navy M-boat (a landing craft capable of holding one large truck). I saw a 7-story building, which housed the "device." It technically wasn't a bomb, since it required 7 truck trailers of cryogenic refrigeration equipment to make it go. Built out of one side, and going for 2 miles to the East, across a man-made causeway, was a 10 x 10 foot wide tunnel, built of waterproof plywood, and housing plastic bags of helium for the entire 2 miles.

The reason for this test setup was that the physicists needed to measure the time sequence of the buildup of certain atomic particles, which emerged from the reaction. But they needed to put the measuring equipment far enough away, so they weren't destroyed by the fireball, before the measurement was done (in microseconds). The helium allowed the particles to travel the 2-mile distance, more or less freely, without much air attenuation.

As it was, the bunker housing the particle counters was unique. It was divided into 10-foot wide parallel instrument rooms, with an open window facing the bomb, and some the helium tunnel. Huge thick blast doors, in front of the windows, started swinging downward at just the right time so the particles would pass through just as the door clanged down. Even so, with the fireball and huge air overpressures moving fast, serious damage was done inside those compartmented instrument rooms, especially one whose blast

door failed to drop. But they got the data, downstairs in the recorder room, where there were Tektronix 530 scopes lined up shoulder to shoulder, for high speed transient photography.

For the instrumentation I worked on, our worst experience with instrumentation was with some Ampex tape recorders. We used these as data backups to photographic galvanometer multi-channel recorders, made by Consolidated Electrodynamics Co. The worry was that prompt radiation might over-expose the photographic film, while the Ampex magnetic tape would not be affected. The shelters were extremely humid, partly because the concrete was still curing, and partly from the acids in the battery room.

We did notice that, when we ran tape recorders every day, occasionally a tape take-up reel brake would stick, but it would soon break free. We should have paid more attention, because when we were taken onboard the ship, there was a 2-day delay before the shot. The asbestos brake linings of the Ampex recorders corroded to the ordinary steel of the brake drums, and about half the tape recorders didn't ever move tape. Luckily, the photographic paper didn't darken very much, so we got all our data.

To give an idea of how much those shelters moved, worse than any earthquake, we had ordered Ampex to install vacuum tube clamps to hold the tube bases tightly to the chassis. Unfortunately, the shock was so great that it shook the glass part of the vacuum tubes out of their own plastic base, so the glass part of the tubes were just dangling when we got there. Most of the heavy power transformers were broken off at the feet, and were dangling by their wires.

Light-Emitting-Diodes

HP Journal, Feb, 1969, July, 1970

In the mid-1960's, HP Labs was working on various display technologies, since virtually every product HP made, needed numeric or alphanumeric readouts. NIXIE® tubes, built by Burroughs Corp. were expensive, and had reliability problems, and needed high-voltage drive circuits, which were not compatible with semiconductor technology. Nor did their high voltage drives lend themselves to portable use. Worse, the technology was available to everyone, and products tended to look the same.

Egon Loebner had joined HP Associates from RCA, and had brought with him, a lot of knowledge of electro-luminescent technology. It wasn't long before HP had work going on with so-called III-V compounds. These roman numerals designate the valence of the elements, in the periodic table. In particular, a certain mixture of Gallium, Arsenic and Phosphorous atoms could join properly in a crystalline structure, and then be configured into an electrical junction diode. If you could do everything right, the diode emitted visible red light at 655 nanometers wavelength, when forward biased.

By the late 1960's, the HPA division was buying crystalline Gallium-Arsenide in cigar-sized boules, slicing, polishing, and growing epitaxial layers of arsenic-phosphorous on the top. It must be remembered as a true black-magic, arcane art. At that time, I was burning out in Microwave Marketing, and

asked John Young, to be on the lookout for a somewhat-more technical job, that might appeal to me, and to be a slower pace. It took about two days.

John proposed that I go down to HPA, to head up the LED display group, since it was struggling for direction. Its process shop was tiny, and needed clear product strategies to set materials and assembly direction. I arrived at HPA, to find a department with about 8 people, two equal-level managers, each with a business card which stated they were the official department manager. Apparently HPA Division Manager Don Smith had brought both down from HP Labs, with the promise that each would manage the group, which was the job I just got.

Within two days, the manufacturing man, Gerry Pighini, had resigned. He wanted to move to Fairchild to be with his poker-playing buddy, John Attalla, whom had just left HP Labs. Within about one week, Division Manager (my boss) Don Smith, himself, resigned to join venture capitalist, Jack Melchor. So I started from there, with my new boss, Dave Weindorf. We had one display product, the HP 7000 numeric display, a 5 x 7 matrix character. Using an on-board integrated circuit chip, it decoded the BCD drive data and provided current for each of 21 (abbreviated from 35) diodes on the face. Each die was 10 x 10 mils.

List price of the 7000 was \$35 each. That made them interesting for ultra high-reliability, military applications, but a tough sell for commercial. Yet, we soon landed a surprise contract from the Longines Watch Company, in Switzerland. They bought 1000 sets of 4 digits for a handheld sports timer. That single order of \$100K, at a negotiated price of, I believe, \$25 each, set us on our way. I believe, in the first year, the department had total sales of \$250K.

We immediately began working within HP, to find instrument applications, but the price was impossibly high. So we moved out in three directions,

- 1) a simpler 4 x 7 dot-matrix character in cheaper plastic package, and with a latching on-board driver IC,
- 2) a full 5 x 7 dot-matrix with 3 to 5 digits per package, and with external strobing circuitry, that would support full alphanumeric characters, and
- 3) 1/10th inch monolithic digit clusters of 5 or 7 digits, for miniature digital displays (usually with a simple plastic magnifying lens), ultimately used in the HP 35.

With a lot of missionary work, our product strategy began developing a diversity of applications. The full alphanumeric characters got accepted into the new HP 9820 and 9830 desktop computers from Loveland Division, although the monolithics didn't win in the HP 9810. Instead, Fairchild got that job.

A 4 x 7 dot-matrix modified version of the full-strobed numerics did get chosen for Jim Sorden's HP 5300 family of portable frequency counters. That helped us a lot with engineering refinement of the strobing concept. Joe Diesel and Bob Steward worked the technical applications. Vic

Wrooble worked on ceramic materials. Howard Borden ran the engineering, and was a real pro on the esoteric display technology principles.

Howard had worked in the semiconductor industry for some years before coming to HP Labs, and subsequently to our LED group. Interestingly, he fought a lifetime of ultra-sensitivity to certain chemicals used in semiconductor wafer processing. Chemicals like TCE, Tri-Chloro-Ethylene were very common in the industry, and ended up in many toxic plumes underground, which polluted the Bay Area's water supplies.

Our own operation at the intersection of Page Mill Rd and El Camino caused quite a large amount of TCE contamination. The cause was that Palo Alto city code regulations required that the inflammable TCE tanks be put underground, but then they leaked. Our failing was that we didn't have the foresight to install double-walled, leakage detecting tanks. In any event, Howard's super sensitivity remains with him today, even though he has been retired in San Diego for two decades.

One problem with HP applications was the pre-introduction product reviews that each division would hold for Dave and Bill as a final approval meeting. LED's of that day had monochromatic light that was SO red that it was at the edge of the visible spectrum. For older people, the tiny red surfaces that emitted light looked blurry, and Hewlett often complained of how uncomfortable it was for him to focus on the numeric displays. Fortunately, he didn't kill the projects, although the same problem surfaced later when the HP 35 calculator was designed.

In the manufacturing area, it was a different story. The process technology necessary to get light out of semiconductor diodes was nasty. Assume it was a process of 32 complicated steps. Slice into wafers, polish, grow epitaxy layers, diffuse zinc, deposit contacts, dice, assemble, etc. And at all steps, clean, clean and re-clean. It may take 4 to 5 weeks for entering material to hit the tester, to find out if you were going to get light.

Grown single-crystal material was purchased from Monsanto and Bell and Howell. In those days, we were happy to get a cigar-shaped boule with a diameter of 1/2 inch. When sawed, you'd get maybe 1/3 square inch of working material. After processing, the outer 20% of each wafer usually wouldn't work, so even though the die were only 0.010 x 0.010 inches, you still wouldn't get many, and for those the brightness was so variable that they had to be measured and selected and matched for brightness so that matrix digits would have even brightness. The human eye is a tremendous brightness error detector.

I can clearly remember the day, probably in late 1970, when we had a coffee-time cake ceremony. On the wall hung a red cardboard sign, which was just 1 square foot. We had calculated that our entire first 1.5 years had been spent manufacturing only that much material area. Some years later, after Ted Larsen's materials people began growing their own Czochralski crystal "boules," or ingots, they turned out a square foot of emitting material every few hours.

Moreover, by the turn of the millennium, there were spectacular technologies which produced red lights, green lights, and yellow lights. They served brake lights in cars, stop lights at street corners, and everywhere a reliable cheap and sun-insensitive light was needed. And now there are "white LED" lights bright enough to serve as flashlight bulbs. Absolutely stunning, when I think of us struggling to figure how to make a somewhat bright far-red LED in 1970, which couldn't be read in sunlight.

A lot of credit for building the massive production capacity for HPA, goes to Bob Zettler, who had moved from HP to Fairchild a few years before, with John Atalla. He returned to HP in 1972 and took over the department after I left. As I mentioned, the reason I had asked John Young for a transfer from Microwave Marketing Manager, was to find a more relaxed pace, and get off the management treadmill. What I found was a terrifically challenging and technologically fun department, but in less than 3 years, we went from 7 people to 105. More treadmill.

There was also the matter of a totally different personnel culture. HP's instrument culture developed over decades from an almost total dominance over the test and measurement sector of the industry. Thus the environment inside was relaxed and confident, not quite arrogance. There was still stress on project schedules and meeting budgets, but the daily environment was not cut-throat and managers were not sharks.

The semiconductor industry, on the other hand, was total stress. The technology was moving at warp speed, and managers were super-aggressive and difficult personalities. My first introduction to the change I was to face, was a product strategy meeting I attended at HPA, with Milt Liebhaber, the division marketing manager, Dick Soshea, the central R&D manager, Rick Kniss, the product marketing engineer on displays, and several others from my Display Dept. I don't believe that Dave Weindorf, the Division Manager was there.

As I walked in, Milt and Dick were on opposite sides of the table, standing up, and one was pounding his fist on the table, both were yelling at each other. One was smoking a large cigar, and it was what I thought to be a generally disagreeable attitude of the participants. Unfortunately, I was to learn that such behavior was inherited from the semiconductor industry, by way of our hiring people who had previously worked in those aggressive companies. I never got comfortable with those personalities, and that was one reason I moved on after less than 3 years there.

The period around 1970 exhibited a severe economic downturn, and the instrument business was hit like most high-tech companies. The Microwave Division had split, with half moving to Santa Rosa and the remaining group re-named Stanford Park Division. Overlaid onto half the products moving out, the remaining products hit a downturn in sales. In spite of many exciting new products, there were still production employees who had nothing to do. This was the time Bill Hewlett introduced his plan to reduce our production capacity by the simple expedient of taking forced time off every other Friday. Immediately reducing production capacity

by 10%.

It wasn't quite enough, and the SPD production managers were looking for places to move some of their people temporarily. Since our LED group was expanding, we agreed to take on a dozen or so instrument assemblers, and make them semi-conductor assemblers. These are people who work all day looking through a microscope, manipulating ultra-tiny parts with tweezers and mechanical levers. It is boring, yet intricate, and tedious work. In the semi-conductor world, hundreds of such workers, sit shoulder to shoulder, for 8 hours.

Needless to say, those transplanted microwave employees got tired pretty fast, and yearned to return to SPD, but couldn't until the business turned around about a year later. Then we would go out and hire assemblers from Fairchild, who thought our production habits were easy, and indeed they were. We were somewhere between the slave-like conditions of Fairchild, and the more moderate conditions of instrument assembly.

HP 150A Oscilloscope

HP Journal, April, 1956

In the 50's, many of the independent HP Reps carried the Tektronix (Tek) product line along with HP. Tek's oscilloscope products were top of the line, and had built an enviable reputation for superb quality and reliability. The inside product design was a dream, with a special ceramic standoff resistor mounting strips and carefully dressed wiring harnesses.

Tek made a decision around that time to take their product sales "direct" meaning no reps. They began on one coast by writing letters of resignation from their business contracts, which were typically a 30-day notice by either party. In the case of HP, and the world-wide sales representatives, we understood that most of those business relationships were on the basis of a handshake and personal friendship, not a written contract.

One after another, as the rep was cancelled, Tek brought in their own people to set up a sales organization. Well, the loss of a general-purpose product line like scopes was serious matter to the HP reps. They prevailed on Dave to agree to design a line of oscilloscopes to compete with Tek. And thereby began decades of frustrating competition. The first two products were a good news-bad news situation. The HP 130A was a slick dc to 300 kHz low-frequency scope that filled a niche that Tek didn't occupy at that time.

But the product that was meant to take Tek head on was the HP 150A. It was a plug-in modular design with dc to 10 MHz, dual channel, which at that time was deemed general-purpose. To avoid a me-too verdict, HP designers chose to use a bottom drawer plug-in which made the plug-ins non-compatible with the Tek design. Some innovations on the CRT made it easier on the eyes. There was a clever "beam-finder" button, which alleviated the nagging problem with the Tek units of losing the trace when overloaded.

But the poor HP 150 suffered the worst reliability problems.

First off, even if perfect, customers would have trouble believing that anyone, even HP could measure up to Tek. They were like Gods. The Tek salesmen had all been trained to be scope repairmen first, salesmen second. Tek President Howard Vollum believed that each and every FE must be able to align a scope and most carried small screwdrivers to tweak the amplifier frequency response of a bench unit as they talked with customers .

It took some years for the HP 150 to become more reliable. Meantime, HP was making more innovations as time went on, such as internal graticules on the CRT. This feature was made possible by the decision to build a CRT manufacturing facility in Colorado Springs when the factory moved out there in about 1960 .

The Tektronix challenge. In the oscilloscope business, HP was the interloper. Tektronix was a major force in the instrument scopes ever since Howard Vollum conceived of a fast, triggered scope just after WWII. Their product design was superior, a soft brushed, and chemically-treated front panel, ultra-clean layouts of control knobs, and an interior layout of components that was clean enough to qualify for an industrial design prize. Before the advent of printed circuit boards, and the cost efficiency they allowed, most wiring was done with hookup wire, hand soldered to vacuum tube sockets, and wires which traveled to insulated spacers which held the circuit components like resistors and capacitors, etc.

In HP products, the spaced component boards were called Kingman cards, named after an HP mechanical tooling engineer, named Rufe Kingman. It was not an unthought-of irony that his first name was similar to Rube Goldberg. He was the comic character who invented complex kluges which had to go through 15 steps of rolling ball bearings and trip levers in order to light a cigarette. The Kingman machine punched holes in a phenolic board, sheared off a short strip of tin-plated brass, punched it through the board holes, and crimped it, leaving a top slot to receive the component such as a resistor for soldering.

Since Tek was ahead to begin with, and HP was playing catchup, it was a frustrating game. HP pioneered in some low frequency scopes like the HP 120 and 130, which were quite adequate for many jobs, and had real easy readability and features like a simple button “beam-finder,” which Tek had never thought of. But soon, they reacted with their own competitive versions.

Larry Johnson recalls, “One technology where HP did innovate was in scope storage tubes. Storage tubes had been around (although not at HP) for some time before HP started using them. I do believe that HP made all of its storage tubes. I believe HP's first tubes were made by Don Hammond's guys down in Bldg 1L. The manufacturing boss and middle-level technology brain was Bert Squires, but the top-level brain belonged to Bill Kruger, a short, gray-haired, quiet, easy-going engineer. Later on, in Colorado facility, Allen Smith was the eventual boss.”

As it worked out, Tek matched virtually every move HP made in scopes. Customers were willing to wait for Tek to come up with an answer. The frustration of the Oscilloscope Division

was great through the years, because although they worked hard and diligently, it was tough to attack the perceived leader. HP, along with a Long Island company called Lumatron, invented sampling scopes and yet were matched a year later by Tek. HP perfected a practical time-domain-reflectometer (TDR) and that was matched soon after, although HP's technology in RF/Microwave ensured that our TDRs were more comprehensive.

At great expense, HP installed a CRT tube production plant at Colorado Springs, to give us quality CRT tube advantages. One result of this capability was that we pioneered display tubes with internal graticules, which provided a highly-improved reading accuracy. But, fighting Tek still remained a very frustrating job for people such as Bill Terry and Hal Edmondson, who had relatively long careers in the HP scope divisions.

Scope camera. There was another product aspect of HP's entry into oscilloscopes. Most scope products of the time were equipped with special bezels surrounding the display. This allowed a special Polaroid camera to be mounted on the front to take permanent pictures of the display waveforms. This was decades before the advent of signal and waveform-capturing computers.

Since HP had its hands full in the first projects to compete with Tek, the decision was made to make our bezels compatible with the Tek scope camera. But there was a corporate pride thing going on, making it hard to recommend a customer buy our scope and go to Tek for the camera he needed. But HP engineering resources were still hard to find for a scope project.

This led Bill Jarvis (scope application engineer) and Cort Van Rensselaer (scope division manager) to set up a small operation in Mountain View to manufacture a compatible camera, which was distributed by HP. At about that time, Bill wanted to leave HP and start his own company, but Cort wished to stay, so they sold their pending patents and inventory to HP.

When HP moved the Oscilloscope Division to Colorado, camera manufacture and design was transferred. There was at least one B camera generation and maybe more. Jarvis used his share of the camera sale proceeds to finance the Wiltron Company startup. Wiltron ultimately became a serious competitor of HP, mostly in the RF and Microwave sectors. Jarvis later sold Wiltron to the Japanese company Anritsu for a reported \$160 million dollars. He took his ownership portion and built a high-end winery in the Napa Valley, one characterized by a huge tunnel bored into a mountain.

The HP 185 Sampling Oscilloscope HP Journal, Jan, 1960

With a market and technology dominated by Tektronix, HP laboratories was always looking for a new unique oscilloscope technology to plant our product flag in the sand. This came with the step-recovery diode technology, and some signal sampling technology which had been used earlier by some nuclear research at the U.S. atomic operations on Long Island. With these, Barney and his lab began an urgent search

for a sampling oscilloscope, which could achieve the equivalent frequency response of 500 MHz.

Although Tek had built some very high priced scopes that did the same job, they were brute force, distributed-amplifier designs which were not welcome by customers. Sampling theory is based on repetitive signals such as a continuing pulse train, which is quite typical of test signals to be analyzed. The sampling point of an extremely narrow sampling window is slowly moved along the repetitive test waveform, and by sequentially plotting those points, a continuous waveform results, exactly reproducing the desired test signal.

When the sampling scope was under active development in the Palo Alto labs, the HP Labs was interviewing a manager prospect who worked at Hughes Aircraft Co. Norm Winningstad was a super-star in their display components labs, which were used in their radar system contracts. It was felt that Winningstad would be valuable in the continuing development of HP scope projects like the sampling scope, which was way ahead in technology. So the lab showed him most of the progress of the project to date. For some reason, I was asked to be one of the interview team. We recommended a hire vote, and an offer was made before he left.

Imagine the chagrin of all of us, when we found out shortly that Winningstad had flown further north, after the HP visit, to Tektronix, and was hired there. The worst was to come, for about 6 months later, as we introduced the HP 185A at Wescon, in Los Angeles, that year, we saw that Tektronix had quickly cobbled together their Type N, a sampling plug-in product for their regular 530 series, which purported to perform to the same sampling specs as our much more refined product system. It was disappointing to see a professional use his HP interview as a spy mission, but such is life. Tek never did catch up with HP on sampling technology, and our products continued to advance.

By the way, the HP promotional gimmick for introducing our first 500 MHz sampling oscilloscope at Wescon that year, were 500 MHz "bills" printed to look like paper money, and handed out on the streets outside the conference. This caused a bit of a problem with the show management because so many of the bills were cluttering the streets as litter.

Wescon also saw HP's first use of commercial billboards, which were rented at sites close to the Convention Center, to announce the new HP 8551. Somewhere, there is a picture record of a screwup by the billboard hanging crew, and I think it might be in the possession of Dean Abramson. The picture shows that several panels were hung in the wrong sequence, such that part of the message was spelled, "Anal Spectrumyzer." My old memory is fading but I think I recall seeing that picture.

ThinkJet Printer

HP Journal, May, 1985

For some years in the 1980s, Barney set up a practice of holding an annual HP Labs Technology Show, in the Bldg 5M auditorium. This was intended to show the employees just what a diverse and dramatic series of R&D projects were

underway in his Labs. It was always exciting to attend and browse through the wide variety of innovative and powerful new products-to-be.

About a year before the ink-jet printer was introduced, HP Labs just showed a technology demo, with a print head driving back and forth, and printing a line of alpha characters. Most of us could hardly believe our eyes, and when told that the engineers had succeeded in blasting millions of tiny droplets of ink out through microscopic holes in a process that happened in microseconds. For us engineers, it was hard to conceive that tiny resistors could be heated fast enough to make tiny droplets of ink explode out of tiny holes at thousands per second. But there it was, writing in front of our eyes.

About a year later, the HP ThinkJet printer was introduced, and as they say in the press, the rest is history. HP's dominance of the printing technology is still held today. And, whether we intended it or not, we got ourselves into the "razor blade" business. You recall that selling consumables like razor blades can be so profitable that you can afford to give away the razor for the revenue you get on a constant stream of sales of razor blades. HP's revenues, which come from the ink cartridges, is not ever revealed separately in their financial reports. I do recall being told by someone, before I retired, that HP ships an amount of ink (in cartridges) annually, which would fill 7 railroad tank cars. I feel quite sure it is much higher these years.

The HP 8410 Network Analyzer

HP Journal, Feb, 1967

Vector Network Analyzers. The HP 8410A Network Analyzer product line of 1968 ushered in a revolution in RF & Microwave component design and test. Multi-band sweeps of Smith Chart characterizations of components and systems arrived at just the right time for exploiting the hybrid microcircuit technology for instruments and communications systems. Paul Ely had coined the product slogan, "Stamp Out Slotted Lines," and the project became an industrial legend.

There was a confluence of technologies in the late 1960's, which resulted in the HP 8410. The step-recovery diode (see below) gave HP a unique sampling technique, and resulted in the powerful HP 185/87 sampling scope. Then the sampling technique was used in a dual-channel RF voltmeter, the HP 8405A, which also measured the phase angle between the two RF signals. This gave RF circuit designers considerable insight into circuits they were extending up to 1000 MHz.

HP then popularized some "homebuilt" reflectometers with dual-directional couplers, which gave customers the ability to measure signal reflections including their phase angle, using the HP 8405A to 1 GHz. But you still had to plot the Smith Charts by hand from the data. When that technique began to catch on, we knew the HP 8410 was on the right track. Meantime, the HP 8708A frequency synchronizer, which disciplined the HP 608F, taught us how to do signal phase-locking to 500 MHz.

Then came the ability to create phase-lock loops, using sampling diodes to lock quiet VHF local oscillators to track

sweeping microwave test signals. And the same sampling diodes were employed to be the dual-downconverters of the HP 8410, yielding a two-channel super-heterodyne receiver which could measure complex impedance to 12.4 first and later 18 GHz. Combining amplitude and phase into Smith Chart type displays gave powerful insight into microwave component design and production. And the signal separation boxes with dual couplers put it all into a nice comprehensive package that truly did, “stamp out slotted lines.”

HP continued to dominate the vector network analyzer category for decades, with lower-frequency range as well as higher-capability products. The HP 8753A vector analyzer (ca. 1987) covered up to 3 GHz. Sometimes called the HP 8510's little brother, it was the first low-cost VNA operating below 3 GHz. This positioned it perfectly for cellular design and test engineers working in the 800-900 MHz, and later 2400 MHz range. It was also the first RF analyzer to have complete built-in error-correction.

Scalar Network Analyzers. Along with the flashy VECTOR network analyzers mentioned, there was another important (and more numerous) category of SCALAR network analyzers. Scalar network analyzers measured SWR (standing-wave-ratio) and reflection coefficient, as well as transmission parameters. These were all scalar parameters, but entirely adequate for production line quality assurance.

The first implementation of scalar analyzers was the reflectometer technique that HP pioneered in 1954. Using back-to-back waveguide directional couplers, and a motor-swept klystron HP 670A signal source, with an HP 416A audio ratio meter, waveguide components could be tested at all frequencies across their band. They were developed for waveguide bands from 2.6 to 40 GHz, and for most coaxial bands.

Next came the HP 890-series sweep oscillators which exploited backward-wave-oscillators (BWOs) for signal generation, making the sweep electronic. This led to oscilloscope displays with calibrations grease-penciled onto the CRT screen, not a very aesthetic solution. The HP 1416A SWR display (ca. 1966) solved that with a scope plug-in that provided calibrated & direct reading reflection and transmission data.

Other families of sweep oscillators followed, with the HP 8690-series and finally the HP 8620A-series (ca. 1970) which featured solid-state YIG oscillator sources for the first time. HP's microwave component research labs contributed exceptional results in the Yttrium-iron-garnet technology coupled with microwave transistors to yield exceptionally stable and high-power sources.

The HP 8540A Automatic Network Analyzer HP 1968 Catalog

The great-grandfather of Agilent's 8510C Microwave Network Analyzer was the HP 8540A Automatic Network Analyzer, which was a two-cabinet system introduced in about 1968. It was the HP 2100A computer programming the HP 8410 and several of its plug-ins, the microwave sweeper signals and the transducer signal-separation boxes. It included

complete operating software for data acquisition and manipulation. Actually, the first 8540A system only had a teletype for the human interface. The HP 8542A which followed was more refined, with a real CRT display and better software.

Both systems had fortuitous timing, since microwave microcircuit-on-sapphire technology was booming (and blooming) and commercial communication satellite technologies were emerging from the Russian Sputnik surprise of 1957, and the U.S. response of their Apollo moon-shot program.

It can be easily argued that satellite technologies have revolutionized the world's scientific and business accomplishments. Weather satellites provide not just tomorrow's meteorology predictions on the evening news, but give crucial warning of gathering hurricane dangers; mapping satellites sense agricultural and mineral conditions on the earth's surface. The Global Positioning System (GPS) determines navigational position anywhere on earth within 20 feet; and maritime and military satellites provide powerful command and control of our defense establishment. The Hubble astronomical telescope searches for the beginning of our cosmos and the Big Bang.

In the late 1960's, I was flying home from a sales trip to Washington, DC. My flight from Dulles was delayed by one of the jet engines spewing raw fuel onto the tarmac. So, all passengers were removed and sequestered in a metal shed out by the flight line, probably to keep us from finding an alternate flight. I struck up a conversation with a fellow passenger, Harold Rosen, who turned out to be the newly-promoted Division Manager of Hughes Communication Company of Culver City, CA. Hughes had developed an awesome communication satellite payload technology, and was already the recognized leader.

After Rosen found out I was from HP, he revealed that he was carrying home a \$69 million dollar contract for the first Comsat communication satellite program. He had just signed the contract with the Comsat Consortium, which consisted of 1/3 U.S. Government participation, and 2/3 from other private communication companies.

In those days, HP employees were permitted to fly first class, if the flight left after normal business hours, so I, as Microwave Division Marketing Manager, had myself ticketed for first class. As we discussed their contract, Rosen noted that he had committed to a penalty clause of \$100,000 per day for late launches. It was common knowledge that the inside of their satellites were a rats-nest of dozens of amplifiers, filters, switches, signal processing components, and a maze of cabling, designed for redundancy and reliability. However the bad news was that, if one part failed, at pre-launch test, they would have terrible delays not just to replace the failed part, but re-test everything to assure integrity of all the hundreds of signal path permutations.

The HP 8540A Computer-Network Analyzer System turned out to be a perfect match, even at \$200,000 each. It was our first use of the new HP 2116A Instrumentation Computer, which programmed and controlled the signal generators,

routing signal switches and network analyzer parts, and collected and corrected all the valuable test data for presentation to the test engineers. And although it was never intended to test satellites, Rosen was highly interested because of his required all-up-around tests on a complete system--especially with his ruinous penalty clauses.

By this time, after a four-hour delay, we got the re-boarding call at midnight. Since I wasn't finished with my sales pitch, I asked Rosen if it would be OK if we talked further on the flight. He said OK. Imagine my surprise when I flopped down in first class, and Rosen walked back into coach class! Carrying a \$69 million contract, no less. After takeoff, I asked the stewardess if I could go back to coach, and Rosen and I spent another 2 hours on the jump seat in the rear, where there was an overhead light, to finish with everything I knew.

If I remember correctly, Hughes bought 3 or 5 of those magnificent systems. And, they launched on schedule, a testimony to their engineering prowess. Hughes went on to become a huge merchant supplier for communications systems to countries around the globe, delivering hundreds of flying birds, each with massive capacities of thousands of voice channels. And that HP system never developed any competition. But in its own way, it helped change the world.

HP 434A Calorimetric Power Meter

HP Journal, August, 1958

Power sensors using devices like thermistors were limited to about 10 milliwatts on the top end. The need to measure higher powers was clearly necessary since most radar and communications systems used watts and kilowatts. Sometimes this could be handled with directional couplers or accurately-calibrated attenuators, which would sample perhaps 1/100th of the main line signal. So it was deemed necessary to build a unit capable of directly absorbing 10 watts, which is where the HP 434A came in.

The HP 434A was a miniature plumbers' nightmare. To dissipate the incoming 10 watt signal, a flowing silicone oil stream was envisioned. Further, to provide an insensitivity to temperature changes and outside environments, a balanced arrangement was used. The same oil stream flowed past the microwave resistor that handled dc to 12.4 GHz signals and proceeded to a temperature sensor. Then after a heat exchanger it went on to another termination resistor and temperature sensor, that accepted only a balancing dc power. By supplying the dc power in proportion to the unbalance in two temp-sensors in a single oil path, a measurement of the dc power equaled the microwave power.

It worked great and the dc substitution made it quite accurate. It had little drift, which was a considerable problem on the previous HP 430/478 power bridge thermistor technology. The idea of measuring medium power directly without resort to couplers or pads appealed to engineers. The product was a commercial success.

Enter the USAF. These were the years of the fear-the-Russians mode. The U.S. was busy building BMEWS, Ballistic Missile Early Warning System, three massive radars in the Arctic, pointed north and looking for inbound missiles

coming over the North Pole. RCA was prime contractor and GE was building the radars. These monsters had antennas the size of a football field tilted up on its side. The radar transmitters themselves, I believe, were 25 Megawatts .

Everything was full military specification design. Including the power monitor system they conceived to monitor the radar system power on a 24 hour basis. For this, they obviously needed a power meter which wouldn't drift, because obviously they couldn't shut down the radar to balance the sensor. The HP 434A was the choice.

The problem; although the commercial HP 434A unit was highly reliable, one reason was that the pump that moved the silicone oil in its path was an ingenious arrangement that didn't depend on a shaft and seal into the oil compartment. Instead it used a magnetically-coupled impeller, operating through a ultra-thin brass shim. The silicone oil path was completely sealed in, no oil leakage.

Well, in the infernal wisdom of the military procurement, GE was told to insist on a "military specification" motor. This in turn required an organic seal on a rotating shaft of a "military specification" pump. The seal and the nasty silicone oil weren't all that compatible. And we looked for future problems. But it met the mil-spec. Confirming that fact, the front panel was specially designed with a golden-colored alodined aluminum sheet, that was 24-inches wide, and 1/2 inch thick to meet expected shocks to be caused by presumed nuclear blasts outside.

Now, flash to years later. At a trade show, I met an RCA field engineer who had spent some years of his life on a BMEWS station site at Farthingdale Moor in the UK, working on maintenance for the radars. He described the site. The radar transmitters themselves looked like the generator room of Hoover Dam, in a structure as long as a football field. Rows and rows of radar cabinets, high-power ancillary equipment, and rows of instrumentation. And about 15 of the HP 434s sprinkled throughout the floor, some operational, some hot-standby units.

He said he'd be standing on a catwalk, and begin to hear a faint piercing squeal from somewhere on the floor. It would begin a resonance that began to drive the cabinet sheet metal into a resonance. And the offender was the HP pump seal. They would track down the bad unit and with a little oil can full of lubricating oil hit the organic seal and be ready for several hundred hours more of quiet.

HP 344A Transistorized Noise Figure Meter

In the early 60's, Bell Telephone (BTL), in their military equipment division at Whippany, NJ, had contracted for an enormous task. They were to build the acquisition radar and the site radar for Nike Zeus, a perimeter defensive missile that was to be placed around hundreds of U.S. cities for defense against the terminal phase of inbound nuclear missiles from Russia. I believe that the ultimate deployment was to be 50,000 missile units and radars. With a project of this scope, operator automation was crucial, and BTL envisioned using an automatic noise figure meter to monitor the radar receiver sensitivity performance, while in full operation.

In radar receivers, one important measure of receiver performance is a parameter called noise figure, essentially an indication of whether it was losing its sensitivity to find targets among noise and clutter. Several years before, we had introduced the HP 340A and then B for commercial applications of making NF measurements. It was built with vacuum tubes.

With the possibility for landing such a whopping contract, New Jersey Field Engineer Bob MacVeety prevailed on Microwave Division Manager Bruce Wholey to develop a transistor version of the HP 340B. The HP 340B, being a vacuum tube model, was not suitable for long-term unattended operation that Bell Labs envisioned. And with the bait of 50,000 units in the future, we were beginning to talk of a future need to build the Bob MacVeety "Memorial Noise Figure Building." Actually, that was some time before Building 5 was contemplated on the Stanford hill site, but would indeed have been Bldg 5.

Well, the upshot was that HP decided to design the new transistorized unit on the basis of an order for about 50 units. And as it turned out, that is all the orders that ever came from that deal. Nike Zeus went away as political administrations changed and politics made such defense systems to be deployed in populous areas extremely unpopular.

The good news was that the engineering efforts needed to design this transistorized instrument became a terrific learning experience for a whole team of excellent engineers. Marco Negrete, Nick Kuhn, and Phil Spohn were all engineers who cut their technical teeth on this difficult design project. All went on to greater achievements, and designed significant new reliable transistor designs, although most of that transistor technology was built on germanium, and some re-learning was needed when silicon took over later.

HP's Frequency Standards, "The World's Timekeeper"

In the post-WWII world of the 1950's, the business and scientific community immediately set to work to commercially exploit many of the scientific breakthroughs which came from wartime developments. And one of the sectors of greatest promise was the area of communications, including everything from wireline to cable multiplex to tactical and mobile technologies, short-wave channels and microwave line-of-sight links. Satellite technologies were waiting just off stage.

The basis of most communication links, which consist of a transmitter and a receiver, is that the transmitted signal containing the modulation and intelligence must be highly stable and in close synchronization with the receiver. (In the receiver, this synchronizer is called the local oscillator.) The most popular way of accomplishing this "signal lock" during that era was to generate the transmitter and receiver signals, and discipline them with quartz crystal oscillators. When properly fabricated, quartz has the property of providing signals of excellent stability related to the physical properties of the tiny slice of quartz.

As accurate and stable as quartz technology can be, it still had

one prime failing. The signal still drifts according to temperature changes and physical conditions and simple aging. One method of re-calibrating those millions of drifting oscillators was to periodically compare the operating systems to several standard signals transmitted by the U.S. National Bureau of Standards (now the National Institute of Standards and Technology) from Boulder, Colorado, on Station WWV. The Bureau's "clock" was in turn referenced to the U.S. Naval Observatory in Washington, DC, which by law was designated as the nation's timekeeper using astronomical readings as their standard.

The Bureau's early clocks were a family of unique, pampered, quartz oscillators, cross-compared and monitored continuously. But as scientific progress in atomic resonance advanced, it was early realized that if oscillators could be synchronized to the atomic resonance of certain elements, they would achieve a fundamental standard from nature. Highly specialized systems were developed at NBS, and put into service as the nation's time standards.

Meantime, Hewlett-Packard concluded that there was a large market for a commercial version of the atomic oscillator, and proceeded with development of the HP 5060A Cesium Beam Standard. It was based on synchronizing to the microwave frequency of one of the atomic resonance lines of the element Cesium. It had been designed to be as compact as any bench instrument, and capable of rough handling and rugged environments, even including an internal battery for mobile operation between the times it could be plugged into ac line power.

Len Cutler was the HP father of atomic time standards at HP's Time & Frequency Division, which later became the Santa Clara Division. While he was a world-class intellect and highly productive inventor, Len would also win an award for "The R&D Lab's Nicest Guy." He always made himself available to answer questions from marketing and customers.

The proof was demonstrated in 1964, with a well-publicized experiment, whereby two HP engineers flew from the U.S. Naval Observatory to the official world timekeeping laboratory in Neuchatel, Switzerland. They configured two "flying clocks" and purchased first-class tickets in an international airline, making sure that suitable sustaining power was available from airplane power supplies.

HP soon became the world's timekeeper, with a continuing line of industry-leading atomic standards. Today, Agilent's cesium clocks provide 80 percent of the weighting of Universal Coordinated Time (UTC), and virtually define the world's standard second and the stability of the atomic second. For decades, Agilent has led the industry with superior cesium standards which have advanced communications on a broad front. In fact, it can be immodestly argued that without Agilent cesium products, most of the world communications would stop cold, including our wireless communications of the 21st century.

Satellite technology is particularly indebted to stable frequency. For example, as a moonshot rocket leaves earth, navigational systems count wavelengths of the disappearing transmitter to measure its distance from earth. All scientific

satellites require precision frequency control to achieve their objectives.

On earth, frequency synchronization of the international communications networks and the Internet system are based on lightwave and fiberoptic technology, and have at their heart, Agilent Cesium standards. Broadcast television and cable systems are likewise synchronized with Agilent standards. Even cellular communications and the thousands of base stations at the center of each cell need long-term stability and reference to cesium standards. Military tactical and strategic systems, with their massive information transfers depend on Agilent cesium products. And most of the world's metrology laboratories which keep time and frequency for their companies and national standard laboratories are running on Agilent cesium standards.

If there was ever a single Agilent product with world impact, many would nominate our decades-long love affair with cesium. It's nice to have a unique product and one which customers love. Sadly around 2005, Agilent management decided to sell off the time standards product line.

HP 2116A Instrumentation Computer

HP Journal, Mar, 1967

Some things happen by serendipity. Sometimes faint visions assist in design or business decisions. I believe that the HP 2116A came about that way. Certainly the IBM mainframe business was rolling along in the mid-60's. Instruments were getting digital, typified by the HP 3440A digital voltmeter, and its sales had taken off. Data logging was only as sophisticated as the HP 560 or 561 printer that displayed the readings of our frequency counters.

Comes a visit from a man at a company in Atlanta, who was working on a mini-computer concept. It was probably Dave Packard who realized that there was going to be an intersection of computer control and data processing functions that could leverage the power of instrumentation. In 20/20 hindsight, it seems simple, but my guess is that the alternative at the time would have been to use data logging instruments and relay programmers for sequencing the control of instrument functions. Indeed, military test systems used that very technology, paper tape sequencers for control and paper tape punches for recording the data.

The HP 2116A brought computed measurement and control right down to the engineer's test bench. The so-called "minicomputer's" design strategy was to provide an accessible card cage on the bottom deck of the product, which allowed individual programmable instruments to be connected to the computer. Each interface card controlled one instrument, either stimulus instruments like signal generators or dc power supplies, or measurement instruments such as fast DVMs, counters or spectrum analyzers.

From the year-2006 perspective, these automatic test systems seem primitive indeed, boasting of a human interface which tolerated a clacking teletype with punched paper tape. The original HP 2116A had a memory made using ferrite core technology, with a basic memory size of 4096 16-bit words (expandable to 8K, at \$1 dollar per byte.) Storage disks came

along a little later, and finally it was modernized with monitor terminals using CRTs.

The real contribution of the HP 2116A was that it was designed so that it didn't need to be coddled, as were most business computers of the time, which existed in temperature-controlled rooms. It was designed specifically for the hostile environmental regime of the factory floor.

The 2116 was extended upward into service as a moderate-priced time-share server, at a time when the General Electric company had created a very user-friendly software application called BASIC. This was quickly accepted by the software-writing professionals, and adopted by the academic community, and ultimately by industry. HP saw immediate applications for BASIC for use in instrument drivers, and appropriate instrument commands were invented to program such instruments.

That system became the HP 2000 Time Share System. But the general explosion of HP's time share revenues was so high it misled our marketing people into thinking that that business was going to go on forever.

HP-Interface Bus.

The high cost of HP's powerful min-computer instrument systems were not available to the ordinary engineer, many of whom still needed such automatic measurement capabilities. It was the confluence of programmable desktop calculators (circa 1972) such as the HP 9810/20/30 and a team of creative brains, which changed things for the better for thousands of HP customers.

George Stanley related to me the history of the beginnings of HP-IB. "In the early 70's Bob Brunner attended an internal HP R&D conference at the Broadmoor Hotel in Colorado Springs, CO. At this conference, Bob said it would be very valuable if HP could find a good way to connect instruments to small desktop calculator/ computers like the HP 9820 and the new HP 9830. Some limited BCD interconnections were considered not robust enough."

"Dave Ricci, SCD, took the job of working it out for high speed instruments like counters and Jerry Nelson, LID, did the same for slow instruments like voltmeters (ac voltmeters took only a few readings/sec). This is how the three wire handshake came about, with a technology allowing the speed to self-adjust to the bus speed of the slowest ACTIVE player in the system. Don Loughry concentrated on the industry standards side of things, and I developed the marketing/ training plan. Of course all our work overlapped, but Ricci is the owner of the three-wire handshake."

The team's vision was to develop a system approach to programming and controlling many of HP's individual instruments such as signal generators, signal measurement products and some unique switching matrixes. The concept was a "party-line" communication bus, which interfaced with some added control and data circuitry inside each candidate HP-IB instrument.

By developing the system in conjunction with an

IEEE/Industry committee, this "open system" created a powerful design capability for applications ranging from research and development to production and support and even field test systems.

The attractiveness of the system depended in good part on the fact that instruments from many manufacturers with HP-IB functionality could be "daisy-chained" together. This permitted ordinary engineers to assemble stimulus signals and measurement products such as voltmeters, analyzers and others. The bus strategy included bus protocols such as handshake and other signal functions along with the data transfer. The resulting data could be conditioned, corrected, manipulated, analyzed or stored.

As the IEEE-488 standard achieved wide global acceptance, it became known as the General Purpose Interface Bus (GPIB). The functionality was designed into most new medium-complexity instruments. It exists to this day, even as much more powerful desktop computers came into being, and even though many of the newest instruments contain their own powerful computational microprocessors, they are still linkable by the GPIB. This permits customers to automate production testing and accumulate test data centrally.

George attended Dave Ricci's retirement party at HP Labs in 2004, because he had something to give Dave. It was an old, actual Washington State license plate that read HP-IB, originally displayed by the HP-IB field specialist in Washington. It was given to George at his retirement, several years before, because of his involvement with HP-IB. But he always felt that Dave was much more entitled to it. Here is George's citation to Dave:

"... I'm not sure everyone here understands the significance of what Dave did when he came up with the three-wire handshake for HP-IB. Very briefly, we had slow instruments like AC voltmeters from Loveland that took 1-2 readings/sec. Then we had Bagley's high-speed counters from Santa Clara that took 1 thousand or more readings/sec.

"If we had gone with the clocked bus we first considered, we would have been frozen in at the slower rate and could not have changed upward as electronics speeded up with ICs. and better circuitry. Ricci's flexible speed, three-wire handshake allowed the bus to run at the speed of the slowest ACTIVE device and slow instruments could be easily kept off the bus until they were needed by simple programming and then turned on to do their thing. This is why Dave holds the patent on the three-wire handshake." As George described Dave's contribution, MC Tom Saponas's head was doing an up and down 'yes.'

In later years, a simpler communication bus was introduced, called the HP-IL, or HP Interface Link. It utilized a simpler bus structure. Both served different customer needs.

The "Bandsaw" Recorder

Discontinued before introduction

Bill Hewlett was an internationalist at the same time he was a creative scientist and engineer. It was Bill's vision that put HP into international sales operations. In HP's early years, the

company depended on use of international sales representatives in various key countries. Later, on several of his early trips to establish company-owned sales entities in the important countries of Europe, Bill had purchased the patents and manufacturing rights to several instrumentation products.

One such product was the Sintef Recorder. Earlier, HP had acquired itself into the strip chart recorder business with the purchase of Sanborn Company of Waltham, MA. Although primarily a medical equipment manufacturer (electrocardiographs), Sanborn's chart recorders had found crucial applications in the booming aerospace industry of the late 1950's, in the telemetry instrumentation applications.

These racks full of recorders and signal conditioning amplifiers were used by the hundreds to monitor mechanical parameters of rockets during live firing tests for vibration and stress and strain measurements. The technology was "pen recorders," which relied on styluses that fed liquid ink out to the tip and produced a clean recorded trace, except that flutter and high frequency oscillations hitting a stylus often would fling ink everywhere, and contaminate the clean multi-trace records.

The Sintef recorder promised to expand that market with a novel ability to plot 10 channels of data, across a 10-inch-wide chart, with a linearity of 0.1%. The bad news was that the technology that was used consisted of a stainless steel band (loop), mounted on two 6-inch diameter spinning wheels, and moving at 100 miles per hour. It looked very much like a shop bandsaw turned on its side. The band itself contained three tiny nibs (needle points) spaced evenly along the band, which contacted the slowly-moving chart paper, which was moving perpendicular to the speeding band.

Ten electronic comparators computed the position of a plotting point (nib) across the chart, and when a given channel required a plotted dot, it triggered a 2000-volt pulse, which burned a tiny, black hole in the white chart paper surface, which had a conducting carbon film on the backside. With 10 channels, that meant each nib plotted 10 points as it raced crosswise across the paper. Each pass happened in 10 msec, so that it could respond to step functions far faster than previous pen recorders. And the linearity was superb.

The Sintef recorder had been the design responsibility of the HP Labs, and unfortunately had not had the benefit of any marketing insight to determine the sales potential based on its product feature set. In the case of products designed by the central R&D lab, once such a product is brought to a manufacturing level, it was handed off to a product division, for manufacture and marketing. In this case, the most likely division was Microwave, headquartered right there in Palo Alto, which was also the home of the HP Labs.

After the original Microwave Division was established in 1962, and since its fabrication shops in Palo Alto had exceptional mechanical capabilities, a magnetic tape recorder product group had been formed under the management of Walter Selsted. Walt was a senior engineer and manager who had worked under the original Ampex founder, Alexander Poniatoff. He had recently left Ampex, and had been hired personally by Bill Hewlett. The objective, most likely, was to

put HP into the high-tech tape recorder system business.

The first HP Labs demonstration of the bandsaw recorder was held for the MWD management, Division Manager John Young, Engineering Manager Paul Ely, Manufacturing Manager John Doyle, and myself. It was a real eye-opener, in more ways than one, and a real test for the sense of smell. As the recorder sat there, plotting 10 channels of slowly moving data, there was an objectionable fzzzz--whizzz--zzzzz sound, and 10 little fuzz balls of fire at each plotting point, drifted across the page. Added to the sound, an acrid ball of smoke rose from the machine.

A far worse defect, we found out later, was that, since the plotting was done with 2000-volt pulses, and the backside of the paper was carbon, the plotting paper coming out the front of the machine acted like a radio antenna, emitting serious RFI, (radio frequency interference). We also learned that 10 of the prototypes had been built, and that \$500,000 had been invested so far, with another \$150,000 to go. Plus Hewlett's original cost for buying the patent in Sweden.

Back at the division, John Young's immediate private reaction was, "We have got to kill that turkey, and not spend another dollar on it." So he wrote a masterful memo to Bill Hewlett, accepting the product into the Microwave Division, pointing out that we would need to do some marketing study. He noted that at the moment, our MW lab was busy with other products, it might take a bit of time to re-initiate the recorder project.

In marketing, I took several of the prototypes and sent them on the road with several of our application engineers. The marketing reports coming back were incredibly negative, as we expected. The noisy sounds, the smoke, and the RFI were just the beginning. It turned out that because it plotted dots, and not continuous lines, it often happened that a fast changing data line would become discontinuous because no dots were plotted for a vertical transition distance. And the "lines" themselves were plotted with fuzzy dots, not the pleasant lines made with ink pens.

The only positive response came from Woods Hole Oceanographic Institute near Boston. They needed multi-channel capability, and had slow moving data, encountered by plotting ocean bottom data. The RFI didn't bother them--since they worked in steel rooms of a research ship--and the smoke was handled by simply opening the door to open air.

The upshot of the market research was that John Young determined to simply kill the project, by means of just shelving it permanently. I made the decision to donate the 10 prototypes to the Woods Hole organization, for their marine research. Which leads to the final fatal flaw of the product. It turns out that the spinning bandsaw nibs moving across recording paper at 100 mph were worn out in less than 10 hours, caused by the fact that any paper is tremendously abrasive. The engineers had tried everything, sapphire, diamonds, carbide, and the hardest of materials. Nothing worked. If the bandsaw nibs wore out every 10 hours, and had to be replaced manually, this fact alone would doom a product which was intended to record long-term (days and weeks) worth of data.

The way we managed that flaw with Woods Hole was that we agreed to donate the tooling apparatus which manufactured the bandsaw band and the plotting nibs. Since they were at sea for weeks at a stretch with an on-board machine shop, it caused no problems.

There are two "the rest of the story" elements to this doomed project. The R&D project manager was Dick Hackborn, who later rose to become HP's Executive Vice President, and a super successful manager of the HP computer and printer operations. He has always received the highest praise for his considerable vision in the product strategies of those arenas. On one occasion, in a management interview, he inferred that his marketing success had come from his insistence on comprehensive marketing and customer insights, before any product was approved for R&D and manufacturing investments.

He admitted that such insistence had, in some way, come from a long-past marketing failure, without mentioning any further details. It is quite ironic that HP's economic gain from Hackborn's powerful management skills at the head of a massive printer operations were gained from a failure to invest some modest marketing study before taking the bandsaw recorder that far into pre-production.

The second element was that some 10 years after we donated the instruments to Woods Hole Oceanographic station, I attended a trade show in Boston. One of the show goers with a Woods Hole badge came into our booth. I recounted the story about the recorders, which were installed on their research boat. Amazingly, the visitor had actually worked for many years on that very research vessel, and reported, "We love those recorders, and are still using them."

"Any problem with the RFI and smoke or wearing out the bands," I asked? "No problem, for RFI, we work in STEEL rooms. Smoke? We leave the door open. We love those instruments, but of course have to make all our own spare bands. But, we have a full machine shop on board, and the machinists often have nothing but time, so we have plenty of bands. Since a lot of our work involves slowly moving functions of multiple channels, such as ocean bottom profiles, they work out perfectly."

So, here was a remarkable case of serendipity, and a hidden contribution to ocean technology.

Bob DeVries told me that the recorder might have been shown in one IEEE show in New York on a private hotel suite demonstration for key customers. It was never revealed to me at the time that customers had seen the finished product. **Several other "failed" products.** There is another footnote here, since there were a few other failed-products that Bill and Dave considered, and spent some time developing, during those earliest years. Dave mentions several of them in his book. So the HP 300A was not truly the second HP product. We learned about these other products over time, sometimes when old field engineers would gather to reminisce.

One such product was the lettuce thinner, an attempt to automate a tedious farm job, done by hand, where a farm

laborer had to walk down rows of growing lettuce, and thin out the crop for optimum growth. HP figured that by using electric photocells, that a mechanized tool could be mounted on a tractor, and do the job more uniformly, and for less cost. I believe that the photocell sensor was the bad performer because it was not constant in its profiling of the various shades of color of lettuce. In the story I heard, Dave laughed that it tore out as much good crop as it left standing.

They also attempted to use the electric photocell as a proximity indicator for the flushing mechanism for men's urinals. I don't remember any description of the reason for not carrying this product into marketing trials, but I think we can guess. It seems to have taken about 50 years for the micro-miniaturization and integrated circuits to make this process feasible, so now they are installed in many commercial establishments. HP's idea was decades ahead of its time, except those ancient photocell components just weren't up to the task. And they weren't low voltage.

Finally, HP actually did design and build a product that was a spot-welding timer. It was based on digital counter technology, since it was possible to digitally set the time needed for spot welding processes, using decade counters. Although forgotten for decades, sometime in the 1960's, when the independent Canadian Sales Company was bought out, and replaced with HP personnel, HP also bought all their assets. One of the assets found abandoned in a warehouse somewhere in Canada, was an actual HP welding timer. I suspect that it ended up in the HP corporate archive and museum.

Microwave Molecular Rotational Spectroscopy

HP Journal, June, 1971

It's hard to believe in these times of billion dollar product winners, that there were times at HP where we actually looked for what we predicted would be \$1 million dollar (annually) winners. So, during the late 60's, we were looking outside the aerospace and high-tech business for ideas for use of our microwave technologies to solve some problems. One of these came up as "molecular rotational spectroscopy." At a molecular level, microwave energy interacts with the slow end-over-end rotation of chemical molecules. So, this HP microwave machine worked on the principle that the molecules of certain low pressure vapors and gases will absorb minute microwave energy at specific frequencies, related to the chemical characteristics of the gas molecules.

By sweeping the frequency inside a sampling chamber called a "Stark Cell," the gas passing through will absorb tiny amounts of the microwave signal. The detection is enhanced by means of pulsing a high-voltage electrode (4000 volts/cm) running down the middle of the cell. This modulates the molecular absorption effect and thereby allows a synchronous detection of the tiny microwave losses in the cell. The resulting swept frequency plot provides a "finger-print" of the various gases, and allows for diagnosis of various chemical reactions.

Howard Harrington was the PhD cheerleader for this chemical analysis project. His enthusiasm never waned, over the many years that HP designed and introduced and sold the

product. He was convinced that there was a Nobel Prize hidden somewhere in the chemical analysis performance that was inherent in his machine.

Alas, it never happened, and the product was transferred to the HP Scientific Instrument Division (SID) over on California Avenue, and integrated into their product line. But, unfortunately, the SID gas chromatograph/mass spectrometer system was just beginning to take off dramatically, so the microwave machine just died. Too bad, since it was a powerful analysis tool. And you have to admit, there aren't all that many HP instruments introduced, which have the ultimate potential to generate a Nobel Prize. Although the Nobel Committee never saw it that way.

General Technology Contributions

There are a few generic HP measurement contributions (mostly non-instruments) which cross all lines of technology and products, yet I feel should be recognized.

Step-recover-diode. Al Bagley related this story. "In the early 1960's, F&T engineer Frank Boff was working on harmonic-comb generators to extend the frequency range of our counter frequency down-converters. One circuit was showing non-intuitive results, with high frequency harmonics that were much more powerful than theoretically possible from a non-linear resistive device such as a diode. To investigate further, he borrowed an early lab prototype of the HP sampling scope to display a time-domain picture of what was producing such rich signals in the frequency-domain. When he finally got the fuzzy picture focused, he didn't see the expected chopped-off top of a sine wave, produced by a diode, but instead saw a sine wave that rose smoothly to almost full amplitude, then suddenly crashed to near zero amplitude."

"At that point, serendipity entered. Frank remembered seeing a paper in the IEEE proceedings, which theorized that such a waveform might exist if a device exhibited a non-linear charge-versus-voltage curve instead of the non-linear current-versus-voltage curve that defined a normal diode. Frank reviewed the article, restudied the strange wave-shape, and proclaimed that what he had taken to be a non-linear resistor, or diode, was actually a non-linear capacitor under certain conditions."

"What he had developed was a variation of the well-known P-N diode which enhanced the stored carrier phenomenon, and achieved an abrupt transition from reverse-storage conduction to cutoff. Remarkably, it was able to switch tens of volts or hundreds of milliamperes in less than a nanosecond. The result was the ability to generate milliwatts of harmonic power at 10 GHz from stable oscillators running at 200 MHz. That device, discovered by an extraordinary engineer, was called the "Boff diode" for a number of years. Sadly, the name was later changed to the more-generic "step-recovery-diode," for marketing reasons. Boff is retired back in his home country, the UK."

HP exploited this new power in a wide variety of products, giving us dramatic and proprietary performance for some years. HP counters used the harmonic-comb signals to down-

convert test signals for counter coverage to 18 GHz. The HP 8410 network analyzer used a two-channel version to down-convert microwave signals for characterizing scattering parameters to 18 GHz. Sampling oscilloscopes, after prototypes were used to discover the effect, in turn, used the diode to generate large-voltage sampling impulses, of extremely narrow width, for measurement of fast-transition test signals in the pico-second range. A whole generation of HP signal generators and sweepers used the rich harmonics to stabilize microwave signals using the technique of indirect frequency synthesis.

Phase-locked loops. HP also became the world leader in exploiting phase-lock loops for frequency control and phase-disciplining of programmable switched microwave oscillators. Using step-recovery diodes to provide rich harmonics from stable and low-phase-noise LF oscillators, and synthesis techniques such "divide-by-n," sophisticated phase-lock loops were used to discipline MW oscillators and reduce their phase noise. The product features that they provided were exact and programmable output frequencies, of exceptional resolution, and superior phase noise performance.

In an associated application, and certainly an example of Bill Hewlett's "next-bench syndrome," HP innovated a new phase-loop stability measuring technique using the previously-mentioned HP 312A selective voltmeter. With an associated tracking generator that produced a signal equal to and tracking with the tuned frequency of the HP 312A, this combination analyzed the closed loop performance of feedback loops, validating the fast switching response and loop stability under wide environmental performance.

PIN diodes. Another variation of the plebian P-N diode was the PIN version, which acted at low frequencies like a regular diode, but at RF/microwave frequencies, it was a programmable microwave resistor. Its construction was simply to insert an intrinsic region of silicon material between the p-region and the n-region. PINs became the centerpoint for broadband control of MW signal amplitudes for power-leveling loops, and as a ultra-fast pulse generator with rise/fall times of nanoseconds.

Edgeline Microwave Switches. Edgeline mechanical coaxial switches were conceived as a dc-18 GHz coax SPDT switch, by Dick Anderson and Steve Adam. The original HP 8761 coax switch was a marvel of simplicity, but dramatic in the performance consequences it bestowed on microwave instruments. It was needed in the late 1960's, during the introduction of the HP 8410 network analyzer, for ultra-low-loss signal switching inside the network analyzer signal separation boxes. In a real sense, those switches became an entire career for Dave Veteran, who engineered the concept

into dozens of components, which were smaller, faster, covered millimeter frequencies, etc.

Between two parallel ground planes, 0.218 inches apart, a 0.182 inch wide beryllium-copper blade was suspended edgewise, such that most of its RF field was forced into the narrow (0.018 inch) separation between the blade edges and the ground planes. Thus, the blade could be mechanically flexed parallel to the ground planes without affecting the signal transmission characteristics of the blade at all. The design caused the blade to mechanically flex from one coax output port to another, using solenoids, making a simple SPDT coax switch. Permanent magnets held those positions without applied power, and the programmability feature was a huge plus.

The next clever design was a programmable step attenuator, which used two of the switches, to switch each attenuator element, in and out of the transmission path. Thus were born the HP 33330-family of step attenuators, 0-120 dB. Later as the more-compact HP 33320-series attenuators, they were used in all signal generators, spectrum analyzers and sweepers to achieve programmable signal control. Then came the HP 33312-family coax switches, which were smaller, 26 GHz, and boasted 80+ dB isolation and 5-port capability.

I was writing a simple application note (AN-332) about that time, which was intended to cover simple applications considerations for using those simple coax switches. I'm not sure when the concept came to me, but I realized that the HP 33312 four-port switch could be sold to microwave automation customers as a "transfer" switch, which could

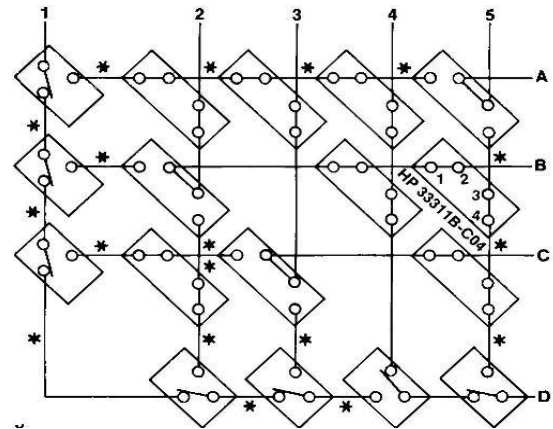

program an external component, say a filter, into and out of a transmission line. So I wrote that application into the application note.

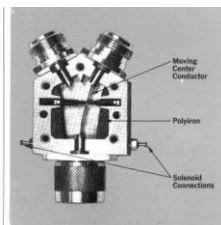
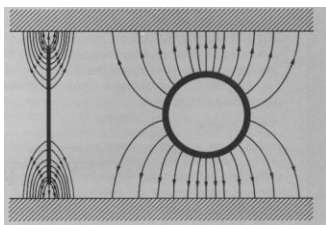

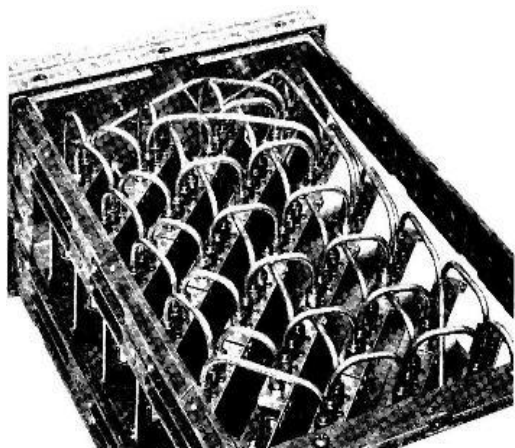

Then I noticed that those same 4-port switches might be used as the “cross-point” switches in a full-access signal matrix. For example, a 4 x 4 matrix (4 input lines and 4 output lines) would require one HP 33312 at each of the 16 line intersections, actually only 12 altogether. So, I included these simple application extensions in an add-on application note, AN-332-1, so customers could build their own full-access matrixes. Soon, customers were requesting that HP quote on building complete matrixes, and we had ourselves a new market.

Some years after retirement I visited Santa Rosa and learned that those matrix switch products have been extended into super sophisticated switching products which have been worth tens of millions of dollars of revenue over those decades.

So, in its own way, this mundane mechanical component idea was perhaps more influential (and profitable) than some of the other glamorous semiconductor breakthroughs of all those decades.

VXI and MMS. In addition to integrating instruments with the HP-IB, in 1987, HP led a consortium of major instrument manufacturers to devise a modular architecture, the VXI. It relied on previous popularity of the computer-industry-standard VME technology, and initially focused on low frequency and RF. VME was an card cage design, with internal power supply and signal bus interconnections. Conceived for portable applications, including military, custom measuring applications can be configured into standardized modular cages. Dozens of available compatible instrument solutions from multiple suppliers are now available, and software routines can be devised to control the measurement process, many now using the modern plug-&-play concepts of hardware and software. A similar open standard was introduced for microwave applications, the MMS, modular measurement system. It was built for higher-frequency signal performance with much more attention to electromagnetic compatibility, interference shielding and RF/microwave signal routing.

Owner Satisfaction

Finally, while not a product for sale, a mention should be made of a continuing HP performance standard which dramatically affected the ownership experience of all HP

customers. This was HP's so-called "**Class B**" operating environmental qualification.

During its infancy of the WWII years, HP occasionally contracted to design militarized test equipment for the rugged field conditions of the armed services. Usually the customer was an aerospace firm, with contracts that required that their support equipment be fielded into the military environment on shipboard or USAF maintenance hangers on test carts, or into field maintenance huts with the U.S. Army. These operating requirements demanded proper operation in a wide range of thermal and mechanical environments. It was found, not surprisingly, that when those HP militarized instruments were commercialized, their failure rate and field reliability were often superior to many other ordinary designs.

This observation led HP to implement an instrument class of environmental specifications that ALL HP commercial products had to meet. The test designation was called Class B, as compared to full mil-spec designs which were Class A. Class B instruments had to operate without harm, from -40 to +65 degrees Celsius, and perform to published specifications from 0 to +55C. In the design qualification phases, the entire parts list was analyzed, part by part, to determine how much derating of components was to be used. For example, resistors were to run at only 75% of their maximum published power ratings.

Since heat is generally the killer of reliability, infrared scans were made on chassis and printed circuit boards to identify spots of unwanted heat, meaning a component circuit was improperly designed. It is generally accepted that these rigid programs of operating qualifications were responsible for the high esteem that our customers, the world over, held for HP products.

••••••••

The HP Culture begins to change

In a real sense, the retirement of Dave and Bill spelled the inevitability of changes in the HP culture. It was bound to happen. The periods of leadership of John Young and Lew Platt made considerable efforts to maintain the wonderful culture that Bill and Dave inspired. But the company grew and grew, and necessarily became more bureaucratic. Once the stock ownership crossed the point where Wall Street was dominant owner, that forced more attention to quarterly financial results. Bill and Dave tended to consider the long term effects rather than short term.

Many of us HP old timers were distressed when the foundation product line of test and measurement was spun off to a new corporate entity, Agilent Technologies. We recognized all the management proclamations on why it was a great idea for both companies. But, for us, Test & Measurement **WAS** Hewlett-Packard.

By the time the Fiorina administration came in, the company was huge, with huge stakes in product strategies and the business sectors that were far removed from the founders' vision. It all seemed to culminate in the year-2000 decision to acquire Compaq Computer, which caused a sensational proxy fight between old and new factions. Many people asked,

“What would Dave and Bill have done?” It is a moot question that I won’t attempt to answer. We all recognize that times change and companies change.

A Public Tribute to Dave Packard. After Dave Packard died in 1996, Stu Center, the T&M catalog manager, tasked me to write a tribute piece for the front pages of his 1997 catalog. In it, I did my best to convey the impact that Dave had on our world during his remarkably-productive lifetime. I believe that this memorial page best summarizes our feelings about the man and his company. Those decades were the **golden years** of corporate employment in the U.S., and most all of us who lived through them would confirm that we were honored and privileged to have been along for the ride.

In Memorium

In Appreciation
of David Packard
1912-1996



The life and career of David Packard influenced the lives of millions of people. Hewlett-Packard customers enjoyed innovative products; competitors found an ethical and spirited rivalry. Visitors to Monterey Bay Aquarium in California learned about sea life, and critically ill children found advanced medical treatment at the Lucile Salter Packard Children's Hospital at Stanford.

The U.S. defense establishment experienced new procurement innovations during Packard's years as Deputy Secretary of Defense. He served on several Presidential Blue Ribbon committees to improve efficiency of U.S. government operations, and was a member of the board of directors of several leading U.S. corporations.

Packard's national service was a reflection of the company's commitment to public volunteerism, which he and partner William Hewlett fostered at HP. Packard supported numerous community and philanthropic causes. He also served as Chairman of the Board of Trustees at Stanford University and Chairman of the Palo Alto School Board. Building on the technology vision of Professor Frederick Terman of Stanford University, Packard helped make the region around Stanford one of the world's most exciting and challenging places to work.

But it was undoubtedly the technology business community and the tens of thousands of HP employees who benefited

most from Packard's leadership and humanity. A lasting legacy is the organizational culture that he and Hewlett instituted and refined, now called the HP Way. The HP Way builds a team spirit and an ethical approach to business relationships, offering an open working environment that inspires employee innovation and service to customers. The HP Way and Management by Objective, both credited to Packard and Hewlett, are the subject of many business school case studies based on the success of the HP management style.

Since its founding in 1939, Hewlett Packard's growth has paralleled the development of the Test and Measurement industry. As HP grew and diversified into new product areas, Packard and Hewlett always insisted that innovations meet real user needs. The current annual revenues of over \$31.5 billion confirm that HP products continue to anticipate and meet those needs. From the beginning, Packard and Hewlett maintained a strong but friendly rivalry with competitors. They recognized that competition fostered innovation, creating better technology and product solutions. One of HP's toughest competitors was the late John M. Fluke, who was also a personal friend of Packard's, dating back to the 1930s when they were engineers with the General Electric Co.

Packard valued contributions in every venture. His spirit lives on in the more than one hundred thousand HP employees, their products and their services. In a real sense, this catalog reflects the test and measurement contributions of his team. The thousands of HP products described here empower engineering, science and business to do a better job and to enhance the future of our world.

We will miss this man. And we will continue the traditions of quality, innovation, and integrity that he inspired.

Appendix

Bill and Dave in the 1930s. There are three Oral Histories by Fred Terman on file in the archives room at Stanford's Green Library. The most important one for understanding the electronics situation in the 1930's is in the interviews about his Stanford academic activities. In it he describes his long rise from childhood, with a serious lung malady which caused him to remain in his home for one year. When he came to run the EE department, he mentored and cooperated with a long line of students and well-known names in the Bay Area electronics field: Charlie Litton, Heinz & Kaufman, Farnsworth of TV fame, the Varian brothers, Eitel and McCullough (Eimac) power tubes, and many, many others.

In the appendix chapter (below) to that Terman oral history, he described the details specific to Dave and Bill in those days. Although interviewed and copyrighted by the Bancroft Library at the University of California at Berkeley, I hereby state that this is a “fair use” by reproducing it here, since there is no financial gain involved, and the quantities are trivial.

A second oral history involved his personal observations on Herbert Hoover, an early President of Stanford and later President of the U.S. The Hoovers and Termans lived near

each other on campus, and Mrs. Hoover and Terman's mother were close personal friends, so he saw quite a lot of Herbert Hoover.

The third oral history involved a final project report on Terman's management of the Radio Research Lab at Harvard during WWII. From its launch in 1942, to closing in 1945, this countermeasures lab produced an AMAZING amount of high-tech war materials. They designed and built thousands of countermeasures receivers in many radio and radar bands, noise and signal jammers, and the old reliable fundamental jammer, aluminum "chaff." Chaff is small strips of foil of various lengths that, when dropped in big bundles, and dispersed by the air, looks like an entire fleet of airplanes, totally confusing the fire control radars for the enemy AA guns. At the end of the war, chaff production was consuming more than 50% of the aluminum foil output of the nation.

In many organizational respects, the RRL was set up much like the HP organization we came to know. The entire program was about 800 people at the end, about half engineers. They had a pilot production area where they could build a few of an early design to check performance in local model shops—like HP. They had production engineers who would take that proven pilot design and approach large industrial electronics production companies, and maybe live at that location for 6 months to bring it into large scale production smoothly—like HP. And they had "service engineers" who traveled to operational military commands to perform the retrofits for those new threat or surveillance receivers into airplanes and ships.

The report was co-authored by Oswald Villard, who was second in command at RRL, and returned with Terman to Stanford after the war. It contains a large number of tabular listings of model numbers of systems, quantities produced and an overview of performance. The accomplishments of that team during WWII in just 3.5 years were stunning.

Later, in a history book of Electronic Warfare, another industry author mentions an amusing incident related to an RRL production team visiting the Delco Corporation in Indianapolis, to negotiate technical and production matters on a new ECM receiver. The RRL team had distributed project documents and stated production requirement at 15,000 units. After long discussions, the Delco team went off to have their own discussions. They came back with the information that technically there was no problem, but they wanted the RRL team to know that they understood the military urgency of the system, and that they were going to turn over heaven and earth to reach the required 15,000 units per month. "No!" said RRL, "We only need 15,000 TOTAL-ever." Delco, of course, had been used to producing car radios for General Motors in the millions of units per year.

Interestingly, Bill Hewlett's job in the Pentagon, working for James McRae, was to serve as the technical overview and procurement manager for much of the countermeasures equipment that came out of RRL. McRae later went on to lead Western Electric Co., a division of AT&T. Terman credits Hewlett's keen technical mind with matching the services needs with the RRL design team and their technologies. This also led to Hewlett-Packard making job offers to a number of

the engineers at Harvard and MIT after the war ended. Bruce Wholey and Art Fong are typical names. Art's expertise was designing klystron signal generators used to test countermeasures receivers.

TERMAN APPENDIX 2: REMINISCENCES OF HEWLETT-PACKARD COMPANY

Scanned and edited from a chapter of a book of Oral History by Dr. Fred Terman, Provost, Stanford University. Copyright 1984, Bancroft Library, UC Berkeley

William Hewlett and David Packard as Stanford Students

Terman: A lot of hams went into the communications industries; they'd liked Eimac tubes when they were hams, and they kept on using them in the equipment that they built for communications systems. If they were putting up a ground station for an airline, they'd use Eimac tubes. They were still devoted to them based on their ham experience. So you got a lot of good commercial business through the strong position developed before when they were in grammar school, high school, and college, with their ham radio clubs.

Susskind: I started to ask you about connections between this first era of development and the EE department of Stanford.

Terman: There weren't really any connections other than the fact that Stanford was the launching platform for Elwell. When I came into the picture, I was interested in these activities and I used to get people from these things to come to talk to students. We used to go out and visit them sometimes; when I knew the people, I made a special effort because I had a personal interest. Some of them were my friends.

Susskind: You mentioned you had been a consultant to Heintz and Kaufman. Was that a common practice for other professors?

Terman: From 1925 to 1937, I was the only one at Stanford who had really any interest in electronics at all. There weren't any other professors even closely related to the field. I did some consulting for a period, not very heavy, and it wasn't terribly significant.

Susskind: Why don't you tell about when Hewlett and Packard graduated?

Terman: As of the middle 1930s, we didn't have very much activity in electrical engineering on the West Coast. There was a little more in Los Angeles, southern California, than around here.

My better students who were interested in electronics ordinarily couldn't find jobs in this area that would be appropriate for their abilities and promise. They'd have to go east and work for General Electric or Bell Labs or Crosley Radio, or something like that. I had a selfish interest in these little companies around here because now and then they might hire one of my fellows. For instance, I got Eldred the job working for Heintz and Kaufman, and so Eldred, who just died, became one of the top men at Hewlett-Packard.

Susskind: And mayor of Palo Alto?

Terman: No, that was Ed Porter, a little later. But Eldred was a very bright fellow and very good engineer, but also good round-about qualities; he got his engineering degree from Stanford in '33. I managed to get him a job at Heintz and Kaufman; he'd grown up in this area and this enabled him to stay here. The alternative was to go east, wear out a lot of shoe leather, and pick up a job from some company. God-knows-where, where he wouldn't want to live anyway.

In the 1920s the best students went to Bell Labs or General Electric. In the 1930s Bell Labs and General Electric didn't do much hiring. But Packard got a job with General Electric, to use him as an example; in 1934 General Electric hired one or two fellows out of Stanford and he was one of them. I was quite annoyed at them because they talked him out of doing graduate work. At the time I thought it would be better for Packard if he'd gone on and gotten a little more training, because he was one of the brightest students we had and obviously had a lot of future.

Susskind: He came back, though.

Terman: Yes, he came back later to do graduate work and got his Engineer's degree with us. But that was a means to an end. I'll tell you that story. I don't know if you know Phil Ekstrand who worked for the Navy up in Bolinas. He was a very bright boy, and he's been submerged, disappeared up in that Mare Island area in the Navy. I developed an interest in these companies partly because they were doing interesting things and partly because they now and then offered an opportunity to place a student.

We had several things going on in here during those depression years that were creative and interesting. There was Litton's operation. Phil Farnsworth began in the late '20s functioning in this area, the first one to demonstrate television pictures with an all-electronic pickup, no mechanical whirling discs. Federal Telegraph had some interesting things until they left; also Heintz and Kaufman, and Eitel-McCullough.

There were some companies here that were independent, owner-managed; that is, the owners were also the entrepreneurs and the technical people. Heintz's company was that way for a number of years and then he tied up with the Dollar Steamship Company. He still ran his end of the show, although he wasn't a complete sole owner anymore. Eitel and McCullough were the entrepreneurs who built the company and also were the top technical people, and Litton was the same way. They were not copying things that people were doing in other parts of the country or trying to do them a little cheaper or carve out a little local market for them.

Hewlett and Packard were two students, both in the class of 1934, who'd gotten acquainted as undergraduates. They came from different parts of the country, and belonged to different fraternities at Stanford, but somehow they were both electrical engineering majors and got acquainted. They decided by the time they were seniors that someday they would like to go into business together, and it would be some kind of electronics business, because they were both electrical engineers.

Dave Packard had a lot of ham radio; Hewlett didn't have any particular background of that sort, but electronics seemed to be the growing and interesting thing, so it would probably be some kind of an electronics business. I got wind of this about the time of their senior year. I had Packard in my class all through the senior year; he took my graduate course in electronics, using my book [*Radio Engineering*], when he was a senior, which was a year before the normal sequence. Packard had been offered a job by General Electric and took it, as I said, to my annoyance, but he was so flattered at being offered this job in the depths of the depression that he worked for General Electric for a few years and did extremely well there.

Hewlett stayed on at Stanford for a year of graduate work. I really got acquainted with Hewlett in that period. Then he went to MIT and did a year of graduate work there, and then came back here. His father was then deceased but had been head of the internal medicine department at Stanford Medical School. He was an M.D. of some note. His father was brought out here to take over internal medicine at Stanford Medical School at the time Ray Lyman Wilbur was made president of Stanford. Wilbur before then had been dean of the Medical School, but also was head of the Department of Internal Medicine and taught regularly as dean. When he became president of the University, he had to quit all those things, and he scoured the country and brought in a man who'd already had distinction; that was Bill Hewlett's father. I think Bill's father grew up in this area somehow, or at least Bill's mother did. There used to be a Coffin-Redington Drug Company in San Francisco; it's now part of a larger, national company.

Bill's mother's name was Redington; she was from that family. It's William R. Hewlett and the R is Redington. There was a certain degree of money, so unlike most of the students during the depression, Bill had, I believe, an independent income from his father's estate, so he wasn't under dire straits to find a job. He finished at MIT and then came back to Stanford and pattered around our electronics lab, playing with some things. There was a woman in the Medical School who was interested in brain-wave phenomena and he built some equipment around 1937 to record these on a roll of paper which passed through and a stylus wrote on it.

Negative feedback had come along; papers had been published on it. I was greatly intrigued by this, and one term I ran a seminar for graduate students in electronics and took the whole term to talk about negative feedback. First we handled it in a tutorial way: I did some of the lecturing; I got students to look up individual articles and make reports on them; and we got several boys building stuff around the laboratory, a dozen students, eight or ten. This was a great new idea, really.

Right in the middle of the seminar, which Dave was auditing, an article came out in the IRE proceedings from General Radio about an audio oscillator using what they called a Wein bridge, a bridge with a frequency-determining element in it. You used a resistance-capacity bridge, a Wheatstone bridge made up of resistances [undecipherable on original tape] and capacities in the arms in such a way that the bridge would balance at a certain frequency and that was the frequency at which this thing would oscillate. So instead of using a coil

and condenser as the tuned circuit frequency-determining element, you used a resistance and a condenser.

It was a negative feedback concept involved. You took the output of the bridge and you fed it back to the input; this was an application of feedback concepts. General Radio had developed a push-button oscillator. You push a button and you can get this frequency or that frequency; you had ten buttons and you could get ten frequencies.

I looked at this thing. You know how universities talk about how they have no money, and their guts are being cut out of them. Well, we were too poor to buy anything back in those depression days and we'd been building our own laboratory instruments, since, we couldn't afford to buy anything. I'd been building oscillators, among other things; we used the students to do these things. These were pretty cumbersome things. I looked at this article and said, "Gee, here, if you just change this thing, and instead of using fixed condenser and fixed resistors and these push buttons, put in a four-gang broadcast tuning condenser, something like ten megohm resistors, you can get this bridge so it will balance as low as 100 cycles." These standard condensers were available very cheaply because they were a standard item in broadcaster receivers. You could get a ten-to-one tuning range; the frequency was in inverse proportion to the capacity, instead of to square root of capacity as in ordinary tuning.

These were designed to tune over three-plus-to-one range, and you square three-plus, and you get around ten. You can get ten-to-one tuning range, and it turns out that if you did, you had enough capacity that, with something like a five or ten megohm resistor, you could get down into the 100 cycles, which was about as low as we were interested in. Then you could change this resistance by factors of ten and you could get a ten-to-one frequency by turning the dial once, and then you throw a switch and you'd get ten-to-one on the next higher range, and you'd go from ten to 100 to 1000, 100 cycles to 1000 cycles by turning the dial once, and you throw a range switch one and you get from 1000 to 10,000, and maybe you could get from 100 down to ten cycles. This would be cheap to build.

So I suggested to Bill, who was looking for something to do, "Why don't you try building this? Here's a really good way to build an audio oscillator. If you're interested, why don't you build one of these things? There are certain problems that you haven't solved about avoiding too much distortion, and if you can get these problems under control, it looks to me like this might be something for which there would be a market. Then you could make these and sell them; they ought to be a lot cheaper than the things that are already on the market. They're simple, and they'd be so much cheaper that people might be willing to accept them even though they are different.

So he built one of these things and worked out a wonderful solution for the principal problem of controlling the amplitude without introducing distortion of the waves. The problem was that you had a pretty good audio amplifier; when you introduced second harmonics you didn't get much tuned circuit discrimination against the harmonics. He had a filament of a lamp that was in one arm of the bridge, a little limiter. As the amplitude and oscillations built up, the

filament would get hot, its resistance would change, the bridge would come in the balance, and this would counteract the tendency for the oscillations to build up. It was a device that didn't introduce any nonlinearity, but stabilized the amplitude at the level where the amplifier didn't overload.

This was the real contribution that he made, and this was just a marvelous solution; I think they're still using it. He got a patent on that. He built a really nice model of this thing and demonstrated it to the [IRE-AIEE] Convention in Portland [1938]. I presented the general idea about the application of negative feedback concepts to laboratory instruments in a paper that was given in New York. This paper has got my name as author, and Hewlett's name as author, and I think Bob Buss was involved. We had three or four different ways in which we used negative feedback in laboratory instruments, and Hewlett's thing was a little section of this.

Formation of Hewlett-Packard Company

Terman: Well, Hewlett felt that they were ready to start a company. I traveled east once a year and I used to be a kind of go-between Packard and Hewlett. You didn't use the long-distance telephone as freely in those days as you do now. Hewlett wasn't much of a letter writer; I don't know if Packard was one or not. Hewlett was interested in forming a company, and was trying to coax Packard to come back and do this. Packard wasn't too sure. He had just gotten married; he was doing very well at General Electric. He'd gotten married by his wife going back there, which saved an extra round trip across the country for him. Remember, this was the depression. He could have had a much fancier wedding here but they didn't; they gave that up. He was a little bit conservative and cautious about giving up a job when he'd just gotten married, and he was very hesitant; it was tentative.

After the invention of the klystron, as a by-product of this, we got [the] \$1000 [I mentioned earlier] given to us by Charlie Litton, who made some observations of something or other; a tube and a number of grids that seemed, under certain conditions of virtual space charge, to get some oscillations generated. Charlie gave some of the patent rights of some of these ideas to Stanford, and Stanford got \$1000 from Sperry, through Litton, to work on these things. It was Sperry's money, but it was Litton's gift. We had just started building some facilities to make tubes over in the electrical engineering department, and we were looking for somebody who could perhaps start using that background and make something.

So Bill wrote a letter to Dave Packard saying we would pay him \$500 to work half time for nine months on this vacuum tube project, [with an additional] \$500 for equipment and material. Packard bought it and came out here. He took a leave of absence from General Electric, and so he didn't burn any bridges behind him. This was what made it practical. I picked up from General Electric during the following year that they just couldn't understand why a fellow as smart as Packard with such great promise in the company, in a company with an internal education program, would leave the great General Electric Company and go back to school and do some more studying.

Susskind: The General Electric program was a pretty good graduate course.

Terman: Packard had gone through their so-called advanced course. Mr. Bowen, who was head of their employment service and the chief man to visit the universities, was the one who was telling them that he just couldn't understand; it just didn't make sense to him, but of course, he didn't have half the story. I didn't tell him the rest of it; I didn't think there was any point in it.

So I hired one David Packard to work half time for me for nine months for \$55 a month. [They] had a little [ceremony] when I retired, in Dinkelspiel Auditorium [at Stanford]. Packard was presiding, and I was telling about the good old days in our lab and the circumstances of work. I said, "We didn't have much money in those depression years, but when you did get a little money, it went a lot further than it does today." To illustrate this, I said that I had once hired a fellow by the name of David Packard to work half time for \$55 a month, and you just can't get people as good as David Packard to work for such salaries today! In fact, Packard hadn't been out here a week until he knew that he would never go back to General Electric.

Hahn: It was a permanent leave of absence?

Terman: That's right. He had the option to return, you see, if it turned out that this wouldn't work.

Susskind: Where did the capital to start the business come from?

Terman: After she graduated from Stanford, and while Dave was working, Lucile Packard tried to get enough money together so that they could get married. She got a job as secretary to the registrar at the University, Pearce Mitchell--the equivalent of the dean of students today. She did this for a couple of years until they got married, and she quit. When she came back, six or eight months after they got married, it turned out her successor as Mitchell's secretary hadn't worked out too well or left, and she got her old job back. She worked a regular 40-hour week as secretary to the registrar of the University, did the Hewlett-Packard bookkeeping and secretarial work in the evening, and kept house as well. [She] made enough money to support the two of them.

Packard had to pay his tuition out of this \$55 a month, too; you didn't get a tuition grant in those days. Bill Hewlett, as I've said, had some independent means, and they put \$538 in a joint bank account. I think Packard had saved up money from General Electric, too. The Hewlett-Packard Company was launched with \$538 of what you might say subscribed capital, and except for stock that employees have been able to buy since 1957, there's never been a dime raised from the public since. The company was started in 1938 or 1939, and in 1957, the only stockholders were Hewlett, Packard, and their wives. The \$538 was the book value of their holdings.

Then they sold ten percent of their stock in 1957 to the public, and that established an over-the-counter market. They later sold another ten percent of their holdings to the public in some private sales. Then they've done mergers where they've

traded stock since, and so now the two families only own about 60 percent of the stock, spread out through the children and a couple of grandchildren as well.

Packard was up for confirmation as Deputy Secretary of Defense, and somebody was concerned about the \$300 million worth of stock—that was real. It wasn't make-believe, because the value of the Packard family's Hewlett-Packard holdings as of that time, if you take all the members of the family, was just about that: the number of shares times the market price on the New York Stock Exchange. Now he owns other things too, including a big ranch down here at Mt. Hamilton, but that was built up entirely from reinvested earnings.

Now the only thing that that company had to sell when they went into business was this oscillator, and they sold it for about \$60 a crack. The competitive article that General Radio made—not of this type, but the normal one where you had coils with taps on them, and you'd switch condensers and you'd get resonant circuits at 120 cycles and so on, that sort of thing—the cheapest you could buy cost \$300 or so.

Susskind: There's some story about General Radio encouraging them in their early days.

Terman: Yes, I can furnish something about this. This was the only thing that they had to sell. Now, they started working on some other ideas of things they might sell later, but for the first year this was it, and they began to sell a few. There was a very aggressive man in Chicago, a sales representative. He got a sample, and was their Midwest representative. He used to carry one of these around; they were small enough to be portable. Portable in the Western Electric sense, or in the General Radio sense, meant that it had handles, but it weighed maybe 60 or 80 pounds.

This thing was in a box (demonstrates) so high, so deep, and so long, and you could carry it in a carrying case on a train with no trouble at all. Every time he made a call he'd show the people this marvelous oscillator that cost so little. People got to buying them whether they really badly needed them or not; an oscillator at that price was so cheap that you knew that it was worthwhile. So he got selling a lot.

An early customer was a fellow named John Hawkins, who was doing the sound work for *Fantasia*, this motion picture with some very special sound effects. He discovered these oscillators and he bought ten or twelve of them in one crack. He used them to tune up the sound systems in that *Fantasia* film, which, of course, got them publicity and helped them very much in the very beginning.

Susskind: Who was the Midwest representative, do you remember?

Terman: A fellow named Crossley.

Susskind: No relation to Crosley Radio?

Terman: No. They started as a partnership, just a legal partnership; it wasn't incorporated. Finally, after ten or a dozen years of operation, it got to the point where tax-wise it

was advantageous to incorporate. Now Packard was married but had no children; they had been married only a very short time. Hewlett at that time was unmarried. Packard rented a house down at Palo Alto, and in the back yard it had a two-car garage, and a one-and-a-half room apartment attached to the garage. Hewlett rented the apartment and lived there, so they were right close to each other. When they got orders, they would park their cars in the driveway and use the garage as the factory. When they didn't have orders, they'd park their cars in the garage, so you could see how business was by just driving past it in the evenings, for example, and seeing where the cars were. If the cars were in the driveway, you knew they had a good backlog.

For the first six-months or so, they did everything themselves. They may have taken something out to get it engraved in a shop, but they had a drill press and a soldering iron. It was a kind of a sheet metal soldering iron technique, and they did it all themselves except to take out for the engraving and painting to some job shops. After about a year of this, Hewlett got married; his wife came from an East Bay family. After she'd graduated from Stanford, she'd gotten a job as secretary to Murray Luck, who was putting out these science reviews.

Hewlett has a kind of funny streak, playing tricks and other little things he does. He got a story circulated; I'm sure he started it. The story was circulating that the reason Hewlett had gotten married at this time was because the Hewlett-Packard Company was getting so successful that the secretarial work was more than Lucile Packard could handle. Maybe she had quit her job, but she was still housekeeping, and doing this work while she was pregnant was more than she could handle. It was up to Bill to provide his share of the support, and that meant that he'd better get married now instead of putting it off. I heard this story from other people, but I'm sure that Bill started it.

Help from Melville Eastham and General Radio Company

Susskind: What about the General Radio support?

Terman: The boys around 1940 or so had a nice little company. By this time they had a few employees. Bob Sink was a graduate student by the time that they were starting; Bill had known him quite well. Bob Sink was a completely self-supporting student; he used to have a room in some faculty home down in Palo Alto; he cooked meals for his board and room, and had done this ever since he was a freshman. But he needed finances, and when he was a graduate student they used to use him to help them when they got more things than they could put together in the speed that they ought to service the customer. They'd get him to come down and work on Saturday morning to help them wire up these things.

So Sink worked there for maybe six months until he got his Engineer's degree at Stanford finished, on a part-time basis after they'd gotten to the point where they needed occasional help. For years he used to go around saying that he was the first employee that Hewlett-Packard had other than Hewlett and Packard themselves. He worked for them for nearly a year, and then he quit. Within the next year they had hired five people to take his place.

The company was beginning to take off. They had a few employees, and they rented a little space down there by Polly and Jake, the antique shop on El Camino and Page Mill Road [in Palo Alto], not more than 15-foot frontage and maybe 25 feet deep. They outgrew the garage because they had continuous work by this time.

Melville Eastham was the founder of General Radio Company around 1915; it was the big electronic instrument company in the United States at that time. They were the ones who created—really invented—the electronic instrument business. A very nice company, very nice, good people; Melville Eastham never went to college but he had a great instinct for design, how to meet a need, and also had some advanced ideas on how to run a company. General Radio was kind of a social institution as well as a very successful company. Eastham's home was, well, he grew up as a boy in Portland, and he owned a ranch out there in Portland, and he often came out here for a period, of the summer. Sometimes he went to Europe for the summer, but he often came out here and spent two months on the Pacific Coast with his wife and he bought them their ranch. He'd come swimming through San Francisco; when he didn't have a convention in San Francisco, then sometimes he'd just come down and visit some of his friends like myself.

Once, around 1940, he was visiting here, and I was telling him about Hewlett and Packard. He'd heard about them because they were mild competitors. So I arranged to take him down there, and I briefed him ahead of time. Eastham was a very unselfish man, but with a great deal of insight. I said, "These are good boys, they've got good ideas, they're very capable, they're well-rounded; I think they're going to make a go of this thing. They've certainly been off to a good start, and this will continue. They're also the kind of people that you'd enjoy having in the business with you, because they won't try to copy your ideas; they have enough ideas of their own. They'll be making their own contributions to the field." Eastham was a great believer in this; he never worried about competition. He disclosed all their secrets, and if he had some difficulty making some part that some competitor wanted to use, he'd sell this component to his competitor, to put something in the market, because if he couldn't compete with the man, then there was something wrong with his organization.

Susskind: He really believed in competition?

Terman: That's right. And cooperation—working together for the common good, and feeling that it was actually in the interest of everybody. I knew he had these ideas, and General Radio became an employee-owned cooperative. They had very, very generous benefits and profit-sharing, and retirement benefits, and so on, and finally ended up with a retirement fund owned by the radio company, which means that it's owned by the employees. When Mr. Eastham retired many years later, he had to sell all his own personal stock back to the General Radio Company, because they had a policy.

The early pioneers who'd owned some stock on their own when the company was founded didn't have to sell back (if you weren't an employee, if you'd been an investor). But he

was an employee, and the newer employees had to sell their stock back that they'd acquired through stock purchase plans; they could own it during the years they worked for the company, but when they retired they had to sell it back. So he applied the same rule to himself. He used to say that Mrs. Eastham owned quite a little chunk of General Radio stock, he didn't know her share; this was after he retired. She was an investor and she didn't have to sell her stock back.

I briefed Bill and Dave privately, and said, "Now, here, open up with this fellow because he'll give you a lot of good advice on how to be successful in business. Listen to him, because he started from nothing and he's made a go at it, and he's interested in sharing his knowledge with people like you." I left him there for the whole afternoon and picked him up at five o'clock or so, and apparently they had a marvelously good visit, because they both said they'd picked up a lot of valuable advice. He was fascinated, he told me after; he'd had a wonderful time looking at what they were doing, talking with them, making suggestions, and leaving much impressed. This was the beginning of a friendly relationship.

Susskind: When did they overtake General Radio in volume?

Terman: At the time of Korea, General Radio suffered from the fact that Melvin Eastham basically retired around 1941, became inactive, and turned over the leadership of the company over to the younger people. He was getting around the middle sixties and was in good health, but he figured that the next generation had better learn how to do this.

During the early stages, 1941-43, he was spending all his time over at the Radiation Lab. He helped set up the RCC reconstruction. He helped them recruit people at first. I've always had a suspicion that he may have been the man that put the finger on me, or suggested me for doing this countermeasures job [at Radio Research Lab]. He never admitted to it. I posed the question to him once; he just said, "No, you were well known; your name came up spontaneously."

I was under the suspicion that he had a hand in tossing my name into the ring in a way that got attention. I didn't know Lee DuBridges, for example, who was the boss man there, and I didn't know the top people that were running that show, the Rabis and the top young fellows, the Alvarezes. I met Luis once. They had to use oscillators and cyclotron, and all the boys at Lawrence's lab had read certain chapters of my book for the electronics they were using in cyclotron work, but they didn't know me personally, so I never did quite know how I'd been suggested.

Wartime Expansion

Susskind: It is said that World War II put Hewlett-Packard onto the [map?].

Terman: They had developed a small line of products by the time the war came on. Hewlett was a reserve officer in the Signal Corps, and I tried to hire him for the Radio Research Lab after Pearl Harbor, on the basis that otherwise the Signal Corps would call him out, and maybe he ought to work for me instead if he was going to do something. They hadn't gotten established enough to know whether they could get

deferments for their owners or not at that time. But Hewlett turned me down, and when the call from the Signal Corps came, he accepted that. He could have gotten out of that and stayed there, but he accepted it, so Packard took over and ran the company during the war.

From '39 to early '42, there was a period of roughly three years in which the company was in existence. Hewlett had done most of the product development and Packard had supervised the production and the accounting and business side of it. Packard had had his fun doing development of commercial equipment for General Electric. He'd done this and demonstrated that he could do it. The business side was a new challenge for him. Hewlett had never played around in the shops, and this was great fun, great sport for Hewlett; he's got tendencies this way anyway. It was great sport for him to create a piece of apparatus that really worked and that other people wanted, so he tended to do more of that in the early days, a good deal more than Packard did. But when Hewlett left to go to Signal Corps, then Packard took over and also did the product development during the early stages of the war, and then other people got involved as the war came to an end.

Susskind: What did the Signal Corps do with Hewlett that was more important than what he was doing?

Terman: Jim McRae was kind of a fabulous figure. For maybe two years in the war, McRae and Hewlett had adjacent desks in the Pentagon. McRae was servicing the generals and colonels that were looking after radar and Bill was servicing the ones that were looking after the rest of electronics. They were personal advisors, guides, on what was sound and what was unreasonable. He didn't have high rank, but he had important responsibilities in the military, and of course he saw a lot of what was going on, so maybe this was good. Maybe Hewlett-Packard's ahead because of that seasoning that Hewlett got.

Susskind: I thought that you meant that he was a line officer somewhere.

Terman: No, he had a desk job. They were tapping his technical ability. McRae was one of the top people in the countermeasures program. He was the one who really got countermeasures apparatus into the air force. He took the steps that enabled us to get our stuff onto the airplanes. The consequences of what he did and his foresight got our stuff on the airplanes.

Let's finish up the Hewlett-Packard business. They developed a nice little company during the war; they expanded and leased some more space, and I think built their redwood building toward the end of the war. During the war there wasn't much business in antiques, and they took over Polly and Jake's front end, and then they built a redwood building, half a block down the same street, which they still own and use. At the peak of the war, they had maybe 200 employees; they gradually built up so that when the war was over, there were nearly 180 to 200 people working for them. It was quite a successful operation. Partly they were providing things that they'd originated that other people needed, and things that they were making on contract with the military services which they didn't originate.

For instance, we planted that signal generator program for them; we developed wide-band tunable oscillators using lighthouse tubes at our Radio Research Lab at Harvard. We also had some wide-band tuning klystrons, reflex klystrons that would tune over two-to-one frequency range or out of any holes in the tuning curves. There was a need for these; we were using them for local oscillators and our long tuning range receivers. But there was also used the same oscillators in some signal generators that we built ourselves in connection with our receivers. The military wanted a source of signal generators that could be bought, and so we worked out an arrangement to take what we had in the laboratory out to a manufacturer who had the competence to build a commercial product.

Well, we brought our signal generator ideas to Hewlett-Packard somewhere around 1944. We sent Bruce Wholey, whom you probably know, a Stanford boy whom I took east with me, out here to teach Hewlett and Packard what we'd already learned. He was one of the engineers who had developed this stuff, worked on it for a year, a long time, with three or four other boys. When the war ended he was still out here, and Hewlett-Packard hired him; he stayed on and runs the division for them now. He was running at one time a medical electronics division.

They had a good business developing. At the end of the war, the husbands came back and wives quit, and out of all of this the company had dropped back naturally to about 110 to 120 people, and then it gradually began to build up again in size. They made certain market decisions which turned out to be very good ones, and General Radio made some different decisions which turned out not to be as good. General Radio, having subsisted all during the depression days, when money was terribly scarce, had the feeling that people wouldn't buy elaborate and expensive equipment, no matter how good it was or what marvelous things it could do; they just wouldn't buy in peacetime a \$5000 or \$3000 instrument for their own use. So General Radio took the policy that they'd try to keep the unit prices of all their equipment below \$1000 or some number like that. They wouldn't build a \$5000 thing or a \$3000 thing at all.

Hewlett and Packard did not make this decision, and they felt that there was an opportunity for microwave signal generators that would be more expensive and that there would be a continuing market. They developed products—some, but not all of them, were fairly high-priced—but they could do things that lower-priced equipment could not do, and they did fairly well in this. Their company was growing steadily and then when Korea broke, there was a big, sudden expansion in the military in electronics activity and military equipment.

In all the companies that supplied military equipment, new things were being developed, and the companies bought a lot of instruments to help them with the new developments. It just turned out that these expensive things that Hewlett-Packard had developed just were right in where the line of great progress was. Electronics in certain channels opened up a great sudden expansion of business, with lots of people getting involved in new areas. They had the instruments that were needed in these new areas, and these people had plenty of money. All at once the company grew very rapidly for a

few years, and that's when they passed General Radio and became the number one company in the field.

Relationship between Terman, Stanford, and Hewlett-Packard Company

Stanford 'played a very important role in getting Hewlett-Packard on the rails because Hewlett was hanging around Stanford and being there, at the right time when an idea turned up and doing the right things with it. I was the one who suggested it to him; I think I even suggested that if he worked this thing out, it would lead to something that he could market and found this company that he'd thought about. [It was a matter of] encouraging him to take a hard look at it. I don't think that Packard would have really come back at that time—maybe he would have come back a year or two later—but Hewlett would have had to struggle along by himself and he would have gone much more slowly. Again, we gave them a kind of a lift at that time.

We don't really take a leadership role but you're dealing with a lot of students. Some of them are bright and have potential, some of them do some great things, and then you look back and you've helped them in some stages, which were at times really unobtrusive but fairly important. You couldn't tell which things would be important; this thing might never have gotten anywhere. They might have built this one oscillator, a pretty good idea, and somehow they'd maybe fumble the ball and not use this as a mechanism for really getting established anywhere, and it would peter out. Now there are simple things that other people don't copy in competition with Hewlett-Packard.

Hahn: Were there other businesses that went the other way among your students?

Terman: It was clear at the time that Kaar didn't have total qualities that Hewlett and Packard had.

Susskind: Oh, but hundreds of businesses go broke in California every year.

Terman: Kaar Engineering is still in existence. I think he sold it about 15 years ago and retired, and he's probably worth a good fraction of a million dollars. But the point was that he didn't have the potential that these boys had, either in technical ability or just overall business sense.

Hewlett and Packard are interesting. Commonly you get two people together, and they're complementary, but actually these people are not. Either of them can do all of the things that the other does and at times has done them. Hewlett's been running the company; Packard's really gone. Hewlett, for instance, for a number of years concentrated on the new product development. Then they started their international operation and Hewlett took that on. On the domestic operations, back in the 1930s through most of the 1950s, if you talked to Hewlett about what was going on in the marketing, the accounting problem: the cost factors, and so on, you found that Hewlett knew just as much about them as Packard did, and if you'd talk to him about some of these things alone, you could get just as quick and clear and quantitative answers as Packard was giving. But Packard was

the guy riding herd on the fellows that were actually making entries in the system and setting up the pattern of the system.

Then when they decided that the international market really ought to be given serious attention, Hewlett was the one who did it. Now this was a business operation, this was setting up. The first thing they did was set up a sales operation for Europe based in Switzerland, and after they got that going, they set up a manufacturing operation in Germany, and subsequently a manufacturing operation in England.

But this was a purely commercial thing in the foreign field. Neither of them knew much about it, but one of them had to learn, and so Hewlett took the job of learning about this and setting it up. This was a business operation and not a technical one. It's been very successful: in the recent six months, something like 20 percent of total sales are foreign, either manufactured abroad or exported.

This is really before Packard left for Washington. They decided that they were getting pretty close to 60 years old, that in eight or ten years, they're likely not to be there or [be] very active; by that time, their company might be a billion dollar-a-year business. They're going to have to teach some fellows now in the company to run a billion dollar-a-year business on their own with father and grandfather not around. That's what Hewlett is carrying on now, their program of increasing responsibility on the younger people.

Susskind: Hewlett and Packard are among the largest participants in Stanford Industrial Park. They occupy about the most space.

Terman: They and Varian between them?

Susskind: They were not in on it in the beginning. They stayed on their side [of the street]?

Terman: They built the redwood building during the war, and then they built a building adjacent to it shortly after the war. When they had to do something more, they came onto the Industrial Park, but they weren't the first tenant. They came in early, but Varian had been there for maybe a couple of years. They got to a point where they had outgrown their existing headquarters building.

Hewlett and Packard each have a remarkable ability to learn as they go along, to stay ahead of their problems, and to establish themselves in new things. Packard was put on the Stanford Board of Trustees in the middle 1950s or so, the youngest member of the board. Here was a younger alumnus who was prominent and public-spirited, and so some of the old fathers of Stanford selected him and invited him to come on the board. About four years later he was asked to be chairman of the board, and he was still the youngest member on the board. He'd made a position for himself with people like Jim Black, who ran PG&E. Dave got on the Stanford board and a couple of years later, Dave turns up on the board of PG&E. You see, Black was impressed with him. And there were people like Black, or Charlie Blythe of Blythe and Company, and John Cushing of the English shipping interests, and so on. This older crowd, much older men, gave him a

great deal of respect, and they made him the chairman. You put these fellows anyplace and they rise to the top.

Another time and independently, some of us out here in the West put Bill Hewlett up for one of the national directors of the IRE. There were two people nominated for every one to be elected, and he got elected. About three years later, I was on the nominating committee, and Bill Dougherty was chairman of the nominating committee, and was on the board at the time, in 1954. I had in mind, quietly, without being too aggressive about it, trying to promote Hewlett as a possible candidate. I was president in 1941, and at the time I was made president I was the first president of that society who'd lived west of Rochester. It was an East Coast operation.

After the war Bill Everett was made president from the Midwest, but Bill Hewlett was the second fellow from west of the Mississippi River who was president. I figured over ten years had elapsed since I'd been president; electronics was growing here; it was about time; and I was ready to promote Bill. Well, it turned out I didn't have to, because Bill Dougherty said, "I've been on this board watching things, and if you look over the board as a source for the new president of this society, a fellow who clearly stands out in terms of his effectiveness and contributions is Bill Hewlett." So Dougherty promoted the thing; I just sat down and enjoyed it.

Now we were required to submit two names, and I had a heck of a time finding a second name that would make some common sense against Hewlett. You didn't want to put up somebody who would be really competitive, but there really wasn't any danger. The real problem, it turned out, of getting a second name was getting someone that would really look reasonably sensible, but wouldn't generate any hard feelings if the board turned him down. [Bill Hewlett] hadn't run with this eastern IRE crowd at all until he got elected director, and he made a position for himself fairly quickly. Again, this is somewhat characteristic.

If you look at the history of the company, it's never had, from the beginning, a really bad year. Now they've had some years where they didn't make more profit than the year before, maybe even a little less profit. But they never had a year of no profit, or even of very small profit. Now most companies that start this way with two technical fellows having an idea and building up, they get built up, and then it gets to a point where they run in some difficulties and have a bad year or two, when they learn how to straighten those out and what they weren't doing right, and then they go along. But Hewlett-Packard just never had a really bad year. Sure, now it isn't so good, their profits are ten percent less than last year, and their sales are running two percent higher than last year. They're only making six and a half percent net profit after taxes on their sales. But for Varian, that would be enormous prosperity, because Varian never made six and a half percent after taxes on its sales.

Hewlett-Packard's target is eight or nine percent, and they're not doing as well as they'd like to do and feel they ought to do. But somehow they learned the things about management, problems that the company has gotten through in successive stages of size, and they've had to delegate more and more things down the line and other people doing them second,

third, and fourth-hand. They've somehow managed to handle management problems in such a way that they haven't had these periodic catastrophes. And I must say, most companies have them.

••••••••

HP Lights

I thought a fitting ending for this narrative for the culture of "our" HP, in what we old-timers consider the golden years of ordinary workers, was a monograph that was published in the HP Retired Employee Club newsletter. It was written by Norena Gutierrez, a 23-year employee, most recently working at Boise. I confess that it left me and a lot of us with a lump in our throat and perhaps a tear in our eyes. It absolutely expressed the way most of us felt inside, as we looked back on our own decades of hard work for OUR company.

Although the HPREC newsletter said that Norena was an HP Retiree living in Spain, it turned out that she was still working in Boise. I contacted her and asked for permission to reproduce her words here. But the really bad news was that she had just been told that she had been Work Force Managed (WFM). WFM, a nasty little modern business acronym (and euphemism) which means you are out of a job. The term hides a strange feeling for most of us because on one hand we know that the external business situation has forced drastic organizational downsizing upon HP and Agilent. But on the other hand, we all know some of those thousands of people similarly affected. In this case, Norena has prepared for her future life in real estate, and we thank her for her dedicated service and wish her well. Happy Trails, Norena.

The Lights Will Still Go On at HP

by Norena Gutierrez, September 2005

They say the "lights will still go on at HP" without me here. I know that is true, but I wonder who will miss me? I wonder who will miss the love I have given this company, I wonder who will miss how much I cared about The HP Way.

I often chose to come in early, work through lunch and stay late.

I thought what I was doing was so important. Especially when it was for customers or when it was something so new, What we were doing would change the world. But the times I was the most selfless, was for my co-workers who needed me. Maybe it was to review a document, give feedback, change the code, whatever! This is what I will miss most, knowing that I was important to my co-workers.

I will miss the lifelong friends I have made
We had so many days of meaningful work together.
We made a difference and we knew it.
We understood the power of a team.

I will miss that where ever I went in the world,

I always found great HP people.
People who cared as much as I did.
People who loved our HP culture enough to keep it precious.
These are the great HP people who shared in success
And when times were tough were the first to say, "We'll get through it together!"

I will miss the picnics and the beer busts.
But mostly I will miss the managers who believed in me, who challenged me, who told me that I was a leader and important to the business.
I will miss the profit sharing checks.

Not for the money but because I knew I was a part of something so much greater than myself.
I will always remember the handshake and the "Thank you" of the general manager.
Those were some of my favorite times.

I will miss the laughter and excitement of creating new businesses and improving processes.
I will miss the serious times when customers' needs were on the line.
We were all engaged for one purpose.
It was our finest hour.
I will miss saying I helped create a great HP product.
And now will relish in how it changed the world.
I wouldn't have missed that for anything.
How proud I am to have been an HP employee.

I would have worked for free for you HP.
I loved you that much.
You should know that I cried when Bill and Dave died.
I had finally figured out what values really mean to a company's culture.
My only regret is I didn't have a chance to say thank you.
I'll take that learning with me as a final gift of all the years, of the great company Bill & Dave built.
I leave you now HP.
I am proud to have been the heart and soul of The HP Way.
I took it for granted for so many years.
I was a guardian of all that was good and meaningful in this company.
Thank you for trusting me to do the best job I could.
That's all I ever wanted to do.

New General References:

During 2005-2009, I became aware of several HP-related instrument and document museums, in unexpected places.

1. This 2010 HPNAR101107 narrative history by Minck is available by Googling it or see Ken Kuhn or Glenn Robb's websites (below) for a download. The 2006 version Hpnar29.pdf is available on this Agilent website. http://cp.home.agilent.com/upload/cmc_upload/secure/Hpnar29.pdf

2. The HP Alumni organization provides a long list of HP historical items, I don't think you have to join to download or link to these items. This is an invaluable source of

information on job networking, alumni benefits, medical payments, job training, job counseling, historical documents and links to interesting HP lore.

http://www.hp alumni.org/hp_history

3. HP 35 Calculator museum:

www.hpmuseum.org

4. HP 9825 Calculator website:

<http://www.hp9825.com/>

5. An HP history collection of Kenneth Kuhn. Amazingly, Mr. Kuhn never worked at HP, but through his own career in instrumentation, always found HP and its products admirable. He has assembled a huge inventory of 400+ vintage HP products, many of which are refurbished into working condition. <http://www.kennethkuhn.com/hpmuseum/>

6. Another museum site of Jon Johnston in Melbourne, Australia, who has established an HP museum (garage): <http://www.hpmuseum.net>.

7. A large assembly of HP historical documentation and a hardware museum of old computers, by Marc Mislange, a retired HP Field Engineer in France. It is called the HP Memory Project. <http://www.hpmemory.org/>

8. A useful website for anyone looking for old documentation from HP and Agilent, run by Glenn Robb. The archive includes application notes, product notes, service notes, catalogs and a LONG list of product instruction manuals. Glenn never worked for HP either, but shares an admiration for the company and its products. www.hparchive.com

9. An interesting interview by Calculator expert Steve Leibson with Tom Osborne, who brought the basic idea for the HP 9100A to Hewlett. Tom describes his years of inventing some unique calculator software and how he built a calculator model without any test equipment. <http://www.edn.com/blog/980000298/post/800022280.html>

10. Michael Malone's book, "**Bill & Dave,**" presents excellent insights into the culture of the company, and is especially good on revealing heretofore little known facts about Bill and Dave's personal lives as students. For example, Bill was dyslexic, which few people who worked with him ever knew.

11. A new book was published in Oct, 2009, by Chuck House and Roy Price, called "**The HP Phenomenon.**" It is extensively researched, with thousands of footnotes and perhaps 300 interviews of key players at HP. It is especially insightful for the CEO period of John Young, when all the crucial decisions were made on computer operating systems. At times HP was selling products with 5 different computer operating systems. Few people remember that he took the company from \$1.9 to \$16.4 billion from 1978 to 1992, a remarkable achievement.

In Conclusion.

Surely, these 98 pages may have been more than you might have wanted to know about the inside of the HP culture in the

fun growth years. And my personal history sidebars were perhaps too much of an extension of what happened to me inside HP. Clearly, every person who worked for HP in those decades would have been able to write about a lot of the same kinds of experiences and friendships.

It was an honor and privilege to be part of the HP/Agilent history. I can only hope that all of our HP/Agilent employees, of the present and future years, will find as much challenge and pleasure in their life's work as I have. I truly doubt that the dot-comers of our age had as much fun.

Acknowledgements

Rev. #0 Circa 1980	Misc. lecture notes
Rev. #1 Circa 2002	Compilation urged by Jim Hall
Rev. #2 October, 2004	Many HP comments added
Rev. #3 November, 2004	Updated
Rev. #4 Feb, 2006	Terman Oral History chap. added
HPNAR29 July, 2006	Engineering creativity, Chance/Barnholt, Snyder bios added
HPNAR30 Sept, 2009	Minor changes, Polly & Jake pix, Anal Spectrumyzer story, more references
HPNAR101107 Nov 2010	Added Chalfant story and Office moves

My original HP narrative was a series of various lecture content and continuing work that I used during the 80's. Since I worked in Bldg 5, overlooking the corporate training facilities on Page Mill Hill at Foothill Expy, I was often asked to brief new field engineers and division employees, in their new employee orientations. I used different portions of these materials.

Along about 2001, I sent a copy to Jim Hall, a Microwave Division engineer and old friend, who moved to Boise in the 70's and made major contributions to our laser printer business. Jim enthusiastically urged me to pick up the task again, to expand and deepen the history and memories of HP's "golden years."

That took about a year, and review comments by a number of people resulted in a reasonably useful history. Rev. #1 was publicized by Ray Tatman in the HP Retired Employees Club newsletter, resulting in something like 250 hits on their website link the first week. It also resulted in an outpouring of commentary from dozens of HP readers who wanted me to know some of their most memorable moments at HP. I saved them all and decided to do a further expansion and correction as Rev. #2.

I am indebted to many people, both for their review comments and corrections and for new, interesting stories of that period; Al Bagley, Dave Kirby, George Stanley, Dave Cochran, Bob DeVries, Ken Kuhn, Dick Rucker, Cort Van Rensselaer, Ron Pratt, Chuck House, Larry Johnson, Jim Macrie, Harry Lewenstein, Bob DeVries, Jim Nagy, Ross Snyder, Monte Smith, and others. In some cases I referenced their names along with their complete stories when they were significant.

HPNAR111107