

Complete S-parameter and Distortion Measurement for Wide Band Video Amplifier

with

HP 4195A Network/Spectrum Analyzer

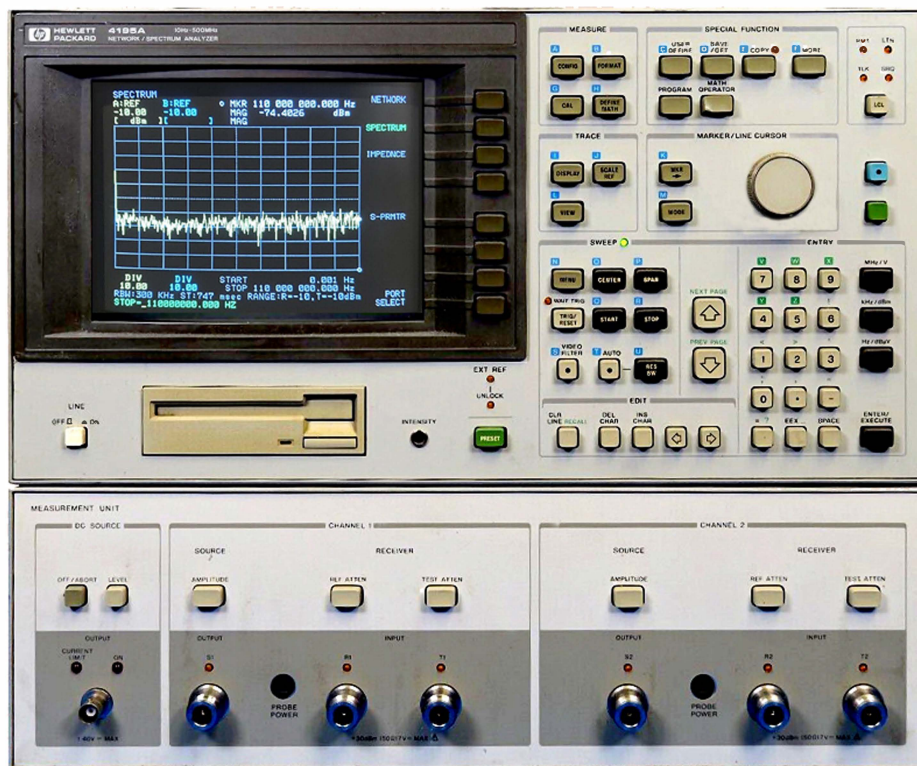

1) Introduction

Advances in communication equipment, and the development of new communication media has given rise to the use of multiple high quality signals, which tend to be low level and high speed. For example, high speed signals found in fiber optic transmitters and receivers, or pulse signals from magnetic heads used in magnetic storage memory equipment. Video amplifiers are often used to amplify these types of signals.

Video amplifiers find wide spread use as broadband amplifiers at frequencies of several MHz to hundreds of MHz (this is known as the "video band"). Video amplifiers require much better high frequency characteristics than do OP amps, and a video amplifier's gain is usually about 20 dB. The DC characteristics of video amplifiers are usually bad, and their gain accuracy is low. Since video amplifiers are used to amplify AC signals with bandwidths which can be hundreds of MHz wide, their characteristics must be known or it will be difficult to produce a good design. Network analysis techniques are used to measure the video amplifier's gain and phase characteristics. Spectrum analysis is used to measure a video amplifier's input/output characteristics, such as checking if the video amplifier causes harmonic distortion.

The HP 4195A Network/Spectrum Analyzer meets the requirements for video amplifier measurements because it combines Network and Spectrum functions in one instrument and its frequency coverage is 10Hz to 500MHz. The 4195A can easily measure gain/phase characteristics and analyze the input/output spectrum of active circuits. In addition, the 4195A does not need a controller to perform complex measurements, because it has many built in analysis functions, and has flexible internal programming capabilities. Therefore, the 4195A speeds up the development process, and improves product quality for video amplifiers.

This application note will describe how the HP 4195A is used to do the following measurements of a video amplifier.

- * Use network function to measure S-parameter, gain, phase and return loss (determine ripple, phase linearity, etc.).

- * Use spectrum measurement function to measure total harmonic distortion and the 50Hz or 60Hz side band power.

2) S-parameter Measurement

S-parameter measurements are performed by measuring power levels with the circuits input and output terminated into a characteristic impedance. Other parameter measurements may require the output terminals to be shorted, but it's difficult to measure these parameters (in this configuration amplifiers tend to oscillate, and the amplifier's shorted terminals are easily influenced by residual inductance and stray capacitance).

In high frequency circuits, S-parameters are used to characterize a circuit's input and output ports. Figure 1 shows the S-parameter measurement concept. There are four S-parameters, S_{11} , S_{12} , S_{21} , and S_{22} . S_{11} and S_{22} are the reflection characteristics, which are used to determine impedance coupling and return loss. S_{12} and S_{21} are the transmission characteristics, which are used to measure gain and phase frequency response. Video amplifiers can be selected for known and uniform characteristics before they are used in a circuit. The 4195A, when used with two R/T test sets, can make S-parameter measurements. Figure 2 shows the 4195A setup in the S-parameter measurement configuration. After making the connections shown in Figure 2, select the S_{11} , S_{12} , S_{21} or S_{22} softkeys, and the 4195A's input and output ports will automatically be configured to make the measurement.

Figure 3 shows the results of a S-parameter measurement. From the S_{21} measurement, this video amplifier's gain is 20 dB, its cut off frequency is about 317 MHz, and at about 150 MHz the gain is down to 1 dB.

S_{12} shows that at the higher frequencies, the output to input feedback increases. Return loss is read directly from S_{11} and S_{22} .

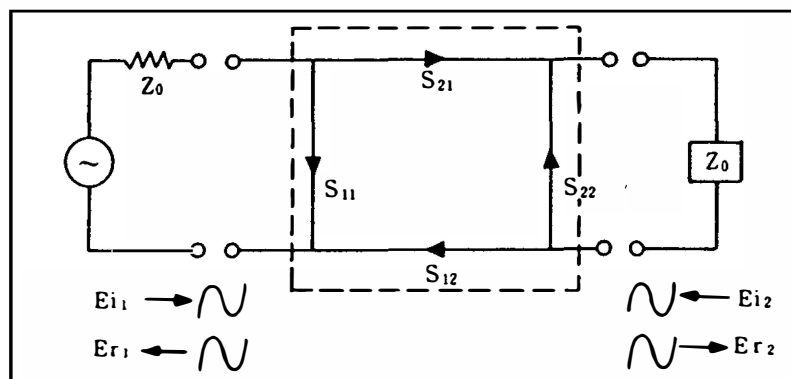

Figure 1. The S-parameter Concept

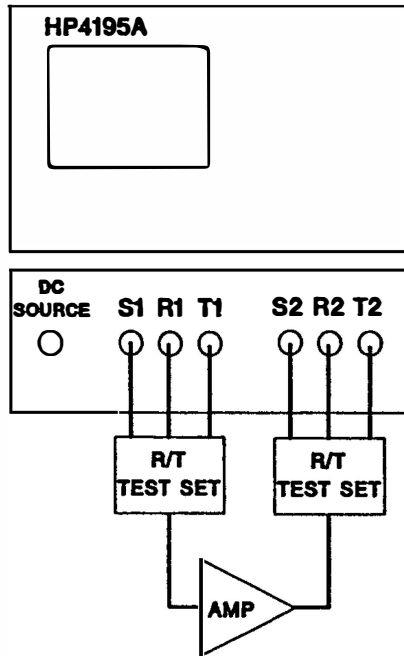
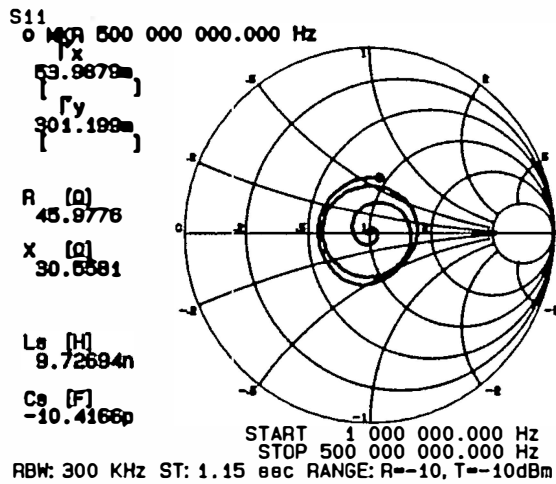
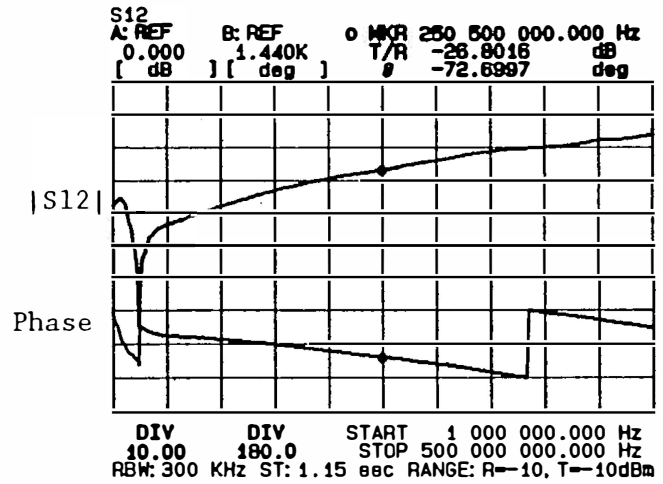

Figure 2. The S-parameter Measurement Configuration



(A) S11



(C) S12

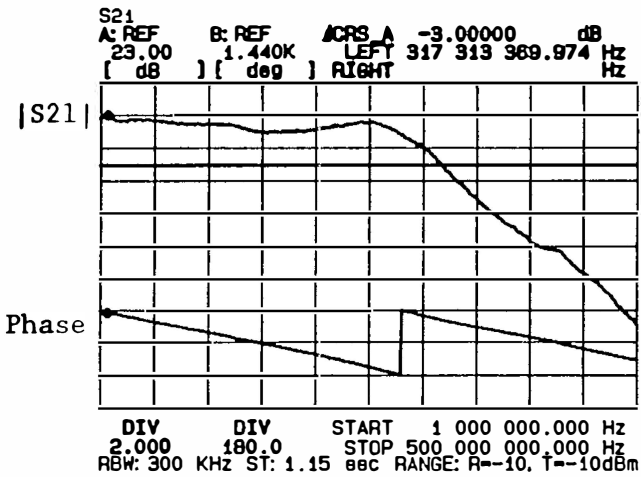

(B) S21

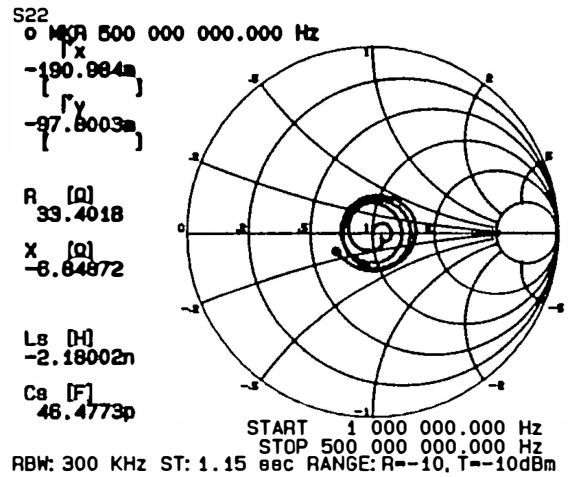

(D) S22

Figure 3. The S-parameter

3) Gain Ripple

If the video amplifier is used to amplify a fixed frequency signal, then gain ripple is no problem. But in many video amplifier applications, the signal being amplified contains many frequency components. If the gain ripple is large, the amplifier can not amplify a mixed frequency component signal with true fidelity in the time domain.

Figure 4 shows the resulting gain ripple measurement. The 4195A with its many marker functions can easily measure gain ripple. The marker function was used to obtain the gain ripple results shown in Figure 4.

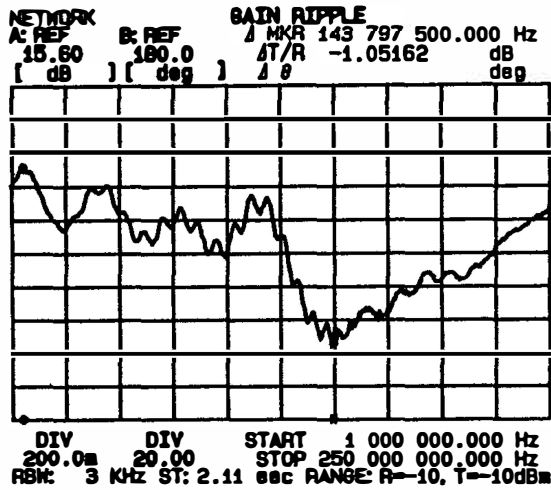
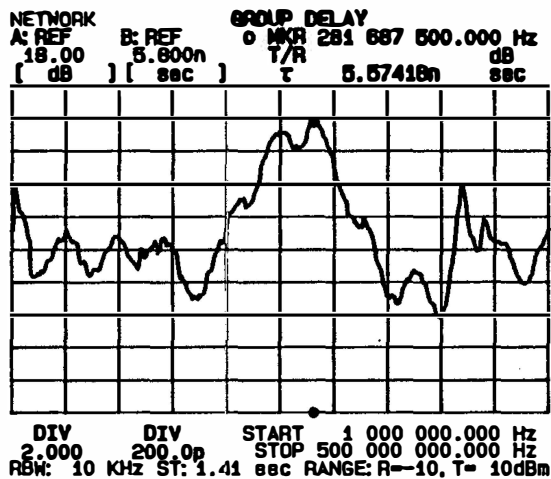

Figure 4. The Gain Ripple

4) Phase Linearity

For video signals and multiple communication signals, phase information is very important. The phase of a signal amplified by a video amplifier is shifted. If the phase changes linearly, the change can be compensated, but if the phase linearity of the video amplifier is poor, compensation will be difficult. Therefore, the phase linearity of a video amplifier is a very important parameter to be measured. There are two methods used to determine phase linearity. One method is to make a group delay measurement, and the other is to make a deviation from linear phase measurement. The 4195A can measure group delay directly, and can use its computational capability to derive the deviation from linear phase. Figure 5 shows the measurement results of a group delay measurement, and a deviation from linear phase calculation. The User Program* used to calculate the deviation from linear phase is shown in Appendix 1.



(A) The Group Delay

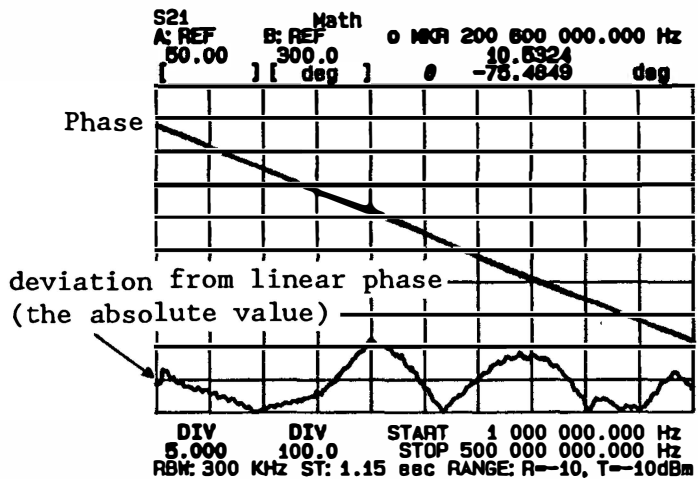

(B) The Deviation from Linear Phase

Figure 5. Phase Measurement

5) Distortion

Harmonic distortion of signals amplified by a video amplifier is caused by the amplifier's nonlinear characteristics. Harmonic distortion is a basic amplifier parameter which the 4195A can measure.

From the results of a harmonic distortion measurement, the 4195A can, with its computational ability, easily calculate the Total Harmonic Distortion (THD). Figure 6 shows the measurement results of a video amplifier harmonic distortion measurement, and THD calculation. The User Program* used to calculate THD is shown in Appendix 2.

* User program are BASIC-like programs that are executed in the HP 4195A to control the HP 4195A's operation without a computer. Refer to the HP 4195A Data sheet for more information on the User Programs.

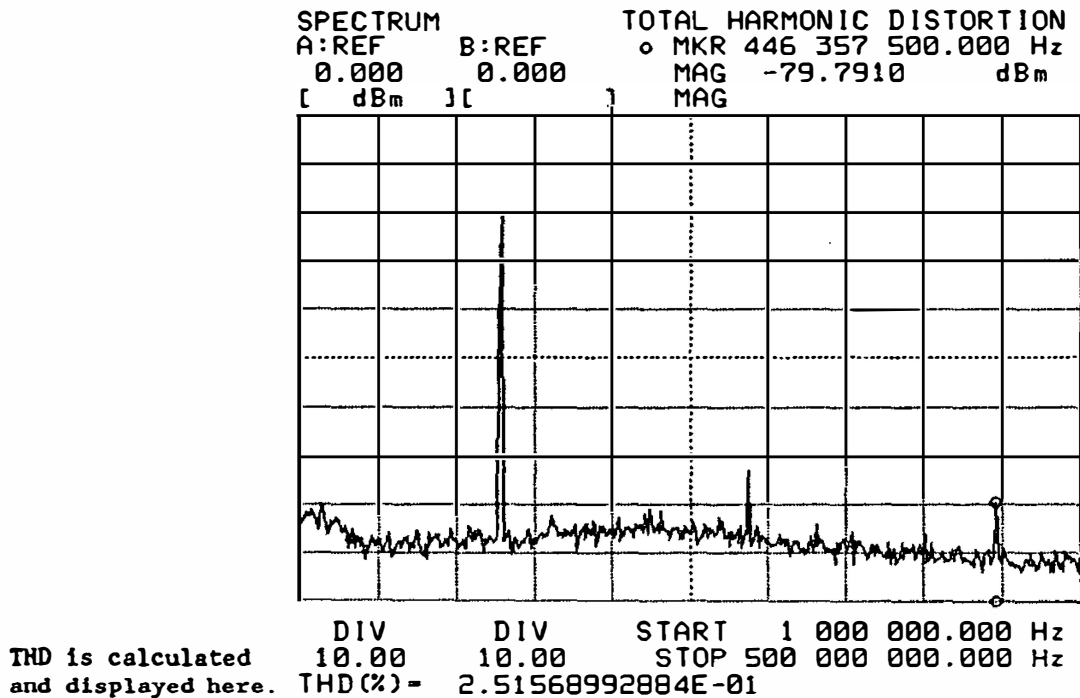

Figure 6. The Total Harmonic Distortion

6) 60 Hz Power Side Band Measurement

For video and all amplifiers, AC noise on the amplifier's power supply lines degrades the amplifiers performance. If the DC power supply voltage includes 60 Hz AC hum from the commercial power line, the amplifiers output will have an unwanted 60 Hz component. This 60 Hz component can be observed as a 60 Hz side band on the amplifier's output spectrum.

To measure the 60 Hz side band, the RBW must be set very narrow so as to isolate the 60 Hz sideband from the carrier signal. Previously, spectrum analyzers were set to a RBW of 3 Hz to measure the 60 Hz sideband, but because the 4195A uses a digital filter, it can measure 60 Hz sidebands with the RBW set to 10 Hz.

Figure 7 shows a resulting 60 Hz sideband measurement. As Figure 7-(A) shows, the side band occurs because the amplifier's power supply is not regulated. Figure 7-(B) shows the output from the amplifier when a regulated power supply is used. This shows that using regulated power supplies reduces the 60 Hz power sidebands. Therefore the sideband power measurement shows the cause of the amplifier's output AM noise and how to reduce it.

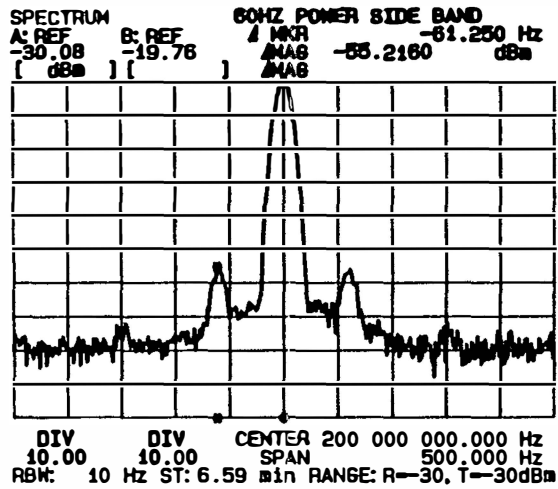

(A) Not Regulated

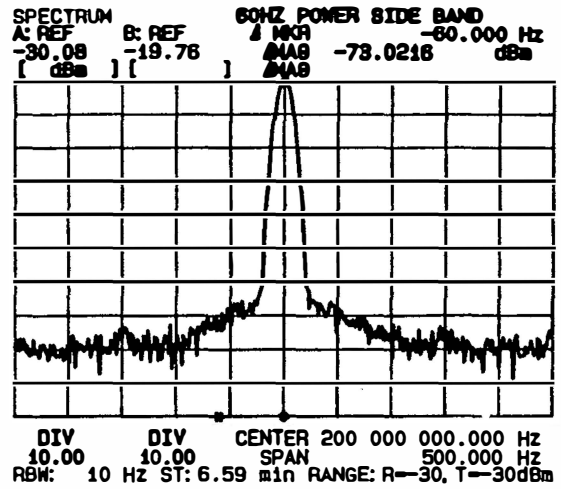

(B) Regulated

Figure 7. The 60Hz Power Sideband

7) Conclusion

The HP 4195A is not only a combination network and spectrum analyzer for components, but it is also a circuit analyzer. It has many analysis functions which previous network and spectrum analyzers did not have, and its basic specifications are excellent.

The HP 4195A can speedily and effectively measure and analyze video amplifiers for circuit design.

Appendix

Appendix 1. The Linear Phase Distortion Measurement Program

```
100 SPC0;SPD0          ! VIEW C & D OFF
110 R1=401*(401+1)/2;R2=401*(401+1)*(2*401+1)/6
120 R3=0;R4=0;R5=R1*R1
130 FOR R0=1 TO 401
140 R3=B(R0)+R3
150 R4=R0*B(R0)+R4
160 NEXT R0
170 R6=401*R2
180 R7=R6-R5
190 R10=(401*R4-R1*R3)/R7
200 R11=(-R1*R4+R2*R3)/R7
210 !
220 FOR R0=1 TO 401
230 D(R0)=R10*R0+R11
240 NEXT R0
250 SPD1              ! VIEW D ON
260 A=ABS(B-D)       !
270 SCL1;REF=50;DIV=5 ! SCALE FOR A
280 DFA1            ! TRACE A ON
290 MCF1           ! o MKR MODE
300 MKCR1         ! MKR FOR A
310 MKMX          ! MKR MAX
320 END
```

Appendix 2. The Total Harmonic Distortion Measurement Program

```
100 SWM2          ! TRIG,SINGLE MODE
110 R2=0
120 MCF1         ! O-MKR MODE
130 MKMX        ! MKR MAX
140 IF MKR<1 THEN NXTPK
150 R1=MKRA
160 FOR R0=2 TO 3
170 R10=MKR
180 NXTPK      ! NEXT PEAK
190 IF MKR<R10 THEN NXTPK;GOTO 100
200 R2=R2+10*((MKRA-R1)/10)
210 NEXT R0
220 R3=100*SQR(R2)
230 DISP "THD(%)=",R3
240 END
```



For more information, call your local HP sales office listed in the telephone directory white pages. Ask for the Electronic Instrument Department, or write to Hewlett-Packard: U.S.A. - P.O. Box 10301, Palo Alto, CA 94303-0890. Europe - Hewlett-Packard S.A. P.O. Box 529, 1180 AM Amstelveen, The Netherlands. Canada - 6877 Goreway Drive, Mississauga, L4V 1M8, Ontario. Japan - Yokogawa-Hewlett-Packard Ltd., 3-29-21, Takaido-Higashi, Suginami-ku, Tokyo 168. Far East - Hewlett-Packard Asia Headquarters, 47/F China Resources Building, 26 Harbour Road, Wanchai Hong Kong. Australasia - Hewlett-Packard Australia Ltd., 31-41 Joseph Street, Blackburn, Victoria 3130 Australia. Latin America - Hewlett-Packard Latin America Headquarters, 3495 Deer Creek Rd., Palo Alto, CA 94304. For all other areas, please write to: Hewlett-Packard Intercontinental Headquarters, 3495 Deer Creek Rd., Palo Alto, CA 94304.

Printed in Japan

Feb. 1988

5950 - 2932