

Measuring Cable Parameters

Application Note 380-2

HP Precision LCR Meters
and Impedance Analyzers

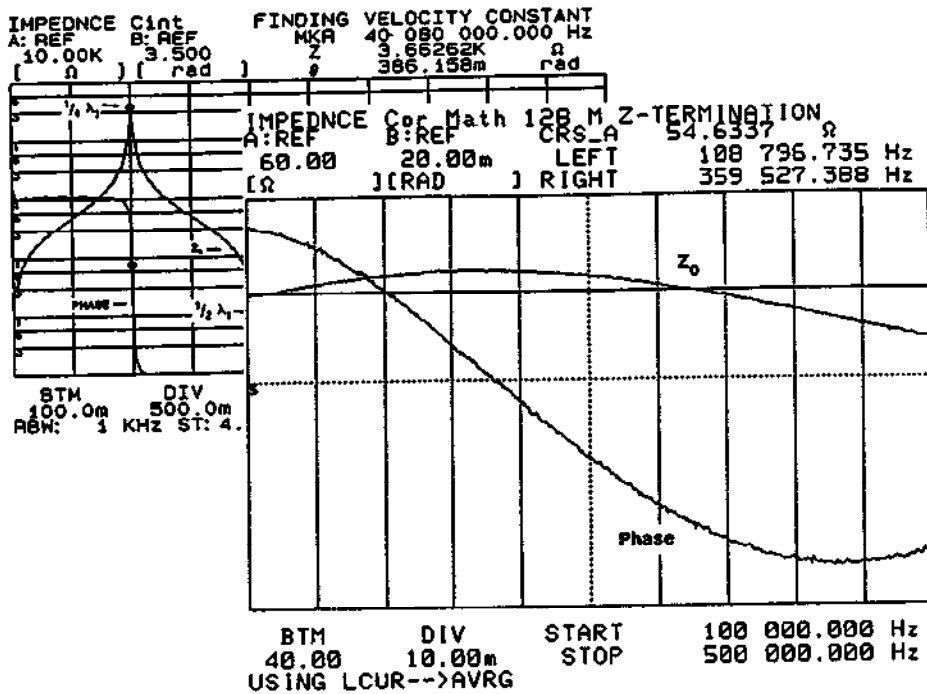

MEASURING CABLE PARAMETERS

USING THE HP 4195A AND THE HP 4284A

INTRODUCTION

This application note describes testing and characterizing cables (Z_0 : *Characteristic Impedance*, pF/m: *Capacitance per unit length*, α : *Loss*, and γ : *Propagation Velocity*). Sweep frequency cable characterization (100 kHz to 500 MHz) using the Impedance measurement function of the HP 4195A Network/Spectrum Analyzer is stressed. Precision fixed frequency cable measurement of capacitance and impedance (20 Hz to 1 MHz) using the HP 4284A Precision LCR Meter is also discussed.

With today's rapid increase in digital communication links, cable characteristics must be viewed differently. Traditional cable characteristics are primarily concerned with efficient energy transfer in RF systems (energy domain). Today, the primary use of a cable is data transfer (data domain). Cable characteristics important in RF work (*Characteristic Impedance, Propagation Constant, Capacitance per Unit Length, Loss*) are still just as important, but cables used for high speed digital data transfer must work in a wide bandwidth environment with low loss and low distortion. The characteristic impedance of a cable must be consistent over the frequency range of the signal being transmitted, and must have low and consistent group delay to minimize distortion.

The advantages of the HP 4195A are: sweep frequency, network analysis, impedance measurement, capacitance, built-in programability, and graphic display capability. Measurement techniques for determining the parameters: *Characteristic Impedance, $\alpha + j\beta$ (Propagation constant), Capacitance, Loss, and Group Delay* are discussed. Time-Domain Reflectometry (TDR) techniques for locating cable faults are also discussed.

You need to know the general frequency response (for example where the resonance points are) to choose the best fixed measurement frequency. The procedure is simple: short one end of the cable under test and execute a single sweep impedance measurement to determine its $1/4 \lambda$ frequency, or trim the cables length until it indicates by measurement that it is $1/4 \lambda$ long at the specified frequency. As frequency increases, a cable must be modelled as an increasingly complex circuit. The frequency does not have to be high to run into trouble when you are using long cables and imperfect impedance terminations. Sweep frequency measurement lets you see the whole picture so you can choose the frequency range to zoom in on. With today's tough design requirements, you must be able to characterize cables under actual operating conditions (impedance terminations, layout, length, etc.).

CABLE MEASUREMENT PARAMETERS

- Z_0 **Characteristic Impedance** primary coaxial cable parameter
- pF/m **Capacitance per meter** second most specified cable parameter
- γ **Propagation Constant** $\gamma = \alpha + j\beta = [(R + j\omega L) (G + j\omega C)]^{1/2}$
- α **Loss** Attenuates signal reducing the signal to noise ratio
- τ **Group Delay** Causes signal distortion

IMPEDANCE MEASUREMENT (HP 4284A, HP 4195A)

The HP 4284A and HP 4195A are used to measure impedance, the HP 4284A is used for high accuracy, fixed low frequency measurements, and the HP 4195A is used for accurate, wide range sweep frequency measurements. Some important instrument features and measurement techniques are given in the following paragraphs.

Error Correction

The error correction features of the HP 4284A and HP 4195A are useful for accurate measurement. Error correction is essential for realizing high measurement accuracy, and for isolating the response of the Device Under Test (DUT) from the responses due to associated measurement support circuitry, (for example, using a *balun* transformer to match a DUT to an instrument's input impedance).

Figure 1 shows the OPEN/SHORT error correction measurement setup. Note that special attention must be paid to seeing that the " SHORT " is the best possible SHORT at the highest frequency of interest. Figure 2B shows the results of using a less than perfect OPEN and SHORT for the frequency range when performing an OPEN/SHORT Z-measurement/ Z_0 -calculation. The reason for the response shown in Figure 2B is that the $1/4 \lambda$ frequency points for the SHORT and OPEN impedance measurements are offset due to the imperfections of the SHORT and OPEN at the frequencies involved (as frequency increases, the quality of any OPEN, SHORT, or IMPEDANCE termination diverges from the ideal, *there are no perfect OPEN, SHORT, or IMPEDANCE terminations*). The results shown in Figure 2A are based on the Z-termination measurement method, while the results shown in Figure 2B are based on the OPEN-SHORT measurement/Z-calculation method. In this case, the Z-termination method gives the more accurate results.

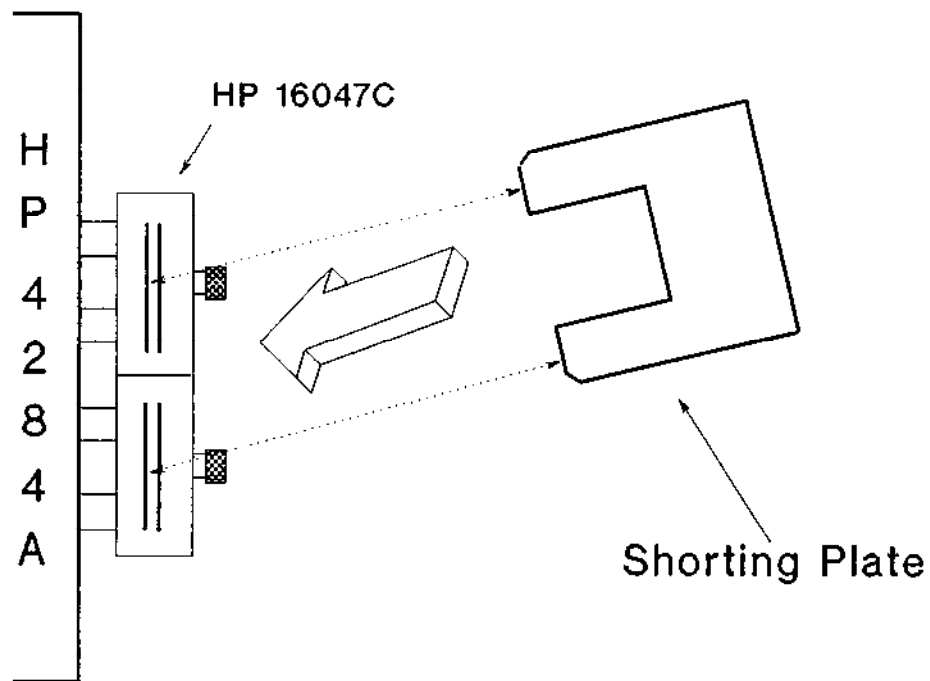

Measure OPEN, SHORT

Figure 1. HP 4284A OPEN-SHORT Error Correction Measurement Setup

Traditional TERMINATION and OPEN/SHORT Z_0 -measurement/ Z_0 -calculation results for a 0.3 meter BNC cable (100 kHz to 500 MHz) are shown in Figure 2, and for a 128 meter BNC cable (100 kHz to 500 kHz) are shown in Figure 3. The Z_0 -measurement/ Z_0 -calculation setup is shown in Figure 4.

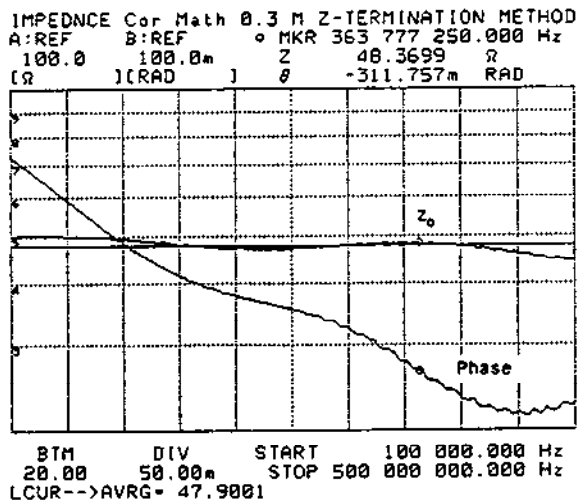

A

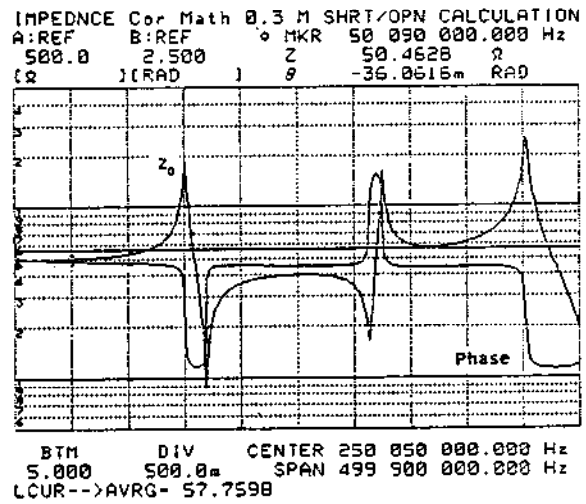

B

Figure 2. Z_0 of 0.3 Meter Cable

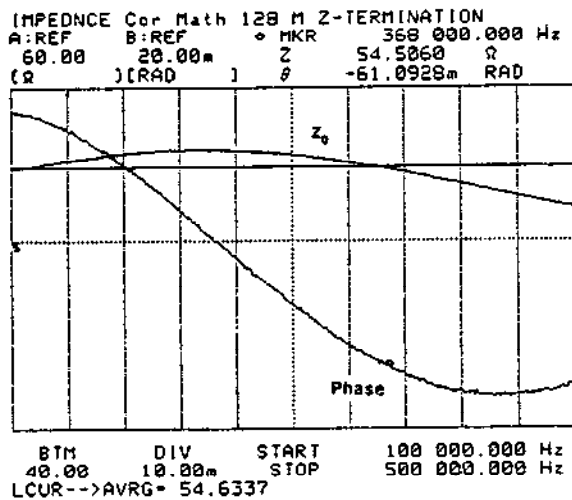

A

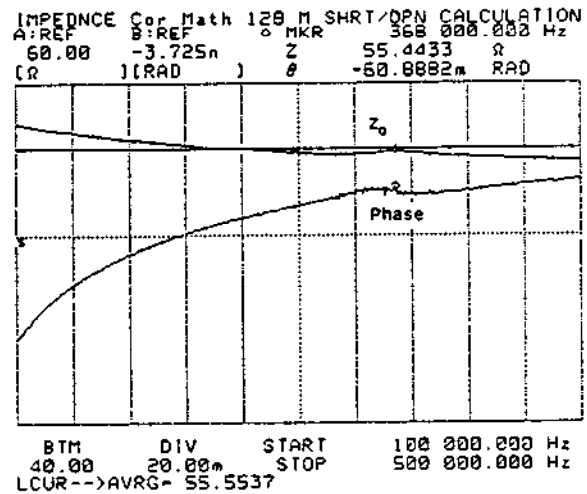

B

Figure 3. Z_0 of 128 Meter Cable

OPEN/SHORT CHARACTERISTIC IMPEDANCE CALCULATION

Characteristic impedance is calculated using measured OPEN and SHORT values. Figure 4 shows the OPEN-SHORT measurement setup.

$$|Z_0| = (|Z_{OP}| |Z_{ST}|)^{1/2}$$

Where: Z_0 = Calculated Characteristic Impedance Value
 Z_{OP} = Measured OPEN Impedance
 Z_{ST} = Measured SHORT Impedance

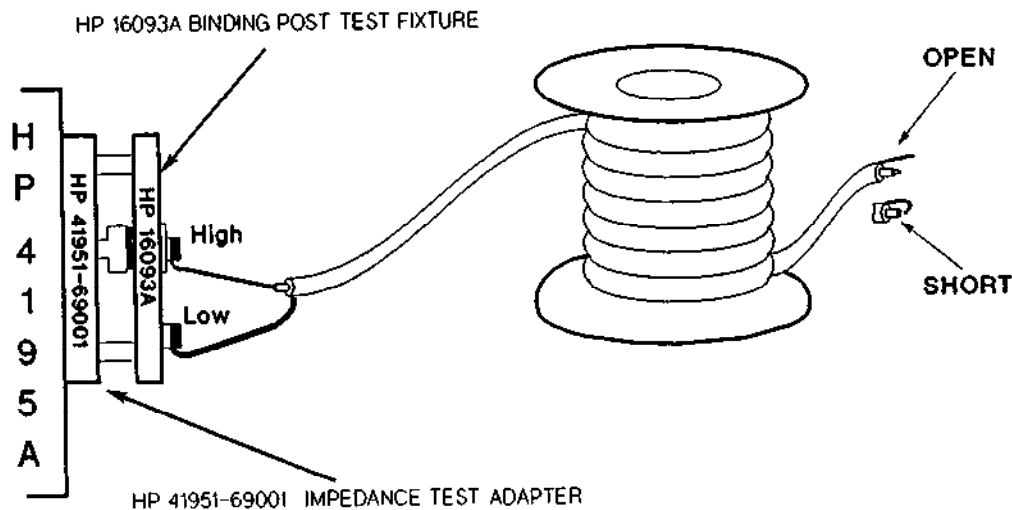

Figure 4. HP 4195A OPEN-SHORT Termination Measurement Setup

MEASUREMENT HINTS

Balanced Cable Measurement Using Balun Transformers

Balanced cables are two conductor cables constructed so that the conductors are parallel, and for shielded balanced cables the impedance of each conductor to the grounded shield is equal. The HP 4284A and HP 4195A have unbalanced (single ended) outputs, so it is necessary to use an unbalanced-to-balanced circuit, *balun transformer*, between the instrument and the balanced cable. Figure 5 shows a typical arrangement for using a balun transformer. The requirements for a good balun transformer are:

- Select the Bandwidth for the test frequency sweep range being used. A maximum roll-off of 3 dB at the selected START and STOP sweep frequencies.
- A balun should have flat impedance characteristics over the frequency range it is to be used. That is, the variation in insertion loss over the frequency range should not exceed 3 dB.
- The SHORT impedance ($|Z_S|$) of the balun should be as low as possible, at least one tenth (or less) of the measured impedance of the cable to be tested. The lower $|Z_S|$ is, the less the additional error is. For example, if $|Z_S|$ is one tenth the impedance of the cable, the additional error is a maximum of 20% of the accuracy of the instrument.

- The balun's OPEN impedance $|Z_o|$, conversely, should be as high as possible, at least 10 times greater than the characteristic impedance of the cable. The higher $|Z_o|$ is, the less the additional error is.

As frequency increases, the physical layout of the cable becomes more important. If an unshielded balanced cable is coiled or bunched up, or layed out close to a ground plane, etc., the high frequency response can vary widely, so cable layout must be given careful consideration. However, when you want to know the frequency response of a cable under actual conditions, measure the cable parameters with the cable layed out as it will be used. Above 50 MHz, as in any RF circuit, careful attention is required to obtain the effective high frequency characteristics of a cable (neat layout, short leads, SHORTs, OPENs, and terminations chosen for good high frequency characteristics, etc.).

When higher impedance measurement accuracy is required, change the **LOAD CAL STD** value (second softkey menu page selected with the CAL function key) to equal the nominal characteristic impedance of the cable. For example, for a 300 Ω balanced twin-lead TV cable, set the **LOAD CAL STD** value to 300 Ω and perform a **LOAD** calibration with a 300 Ω **LOAD**.

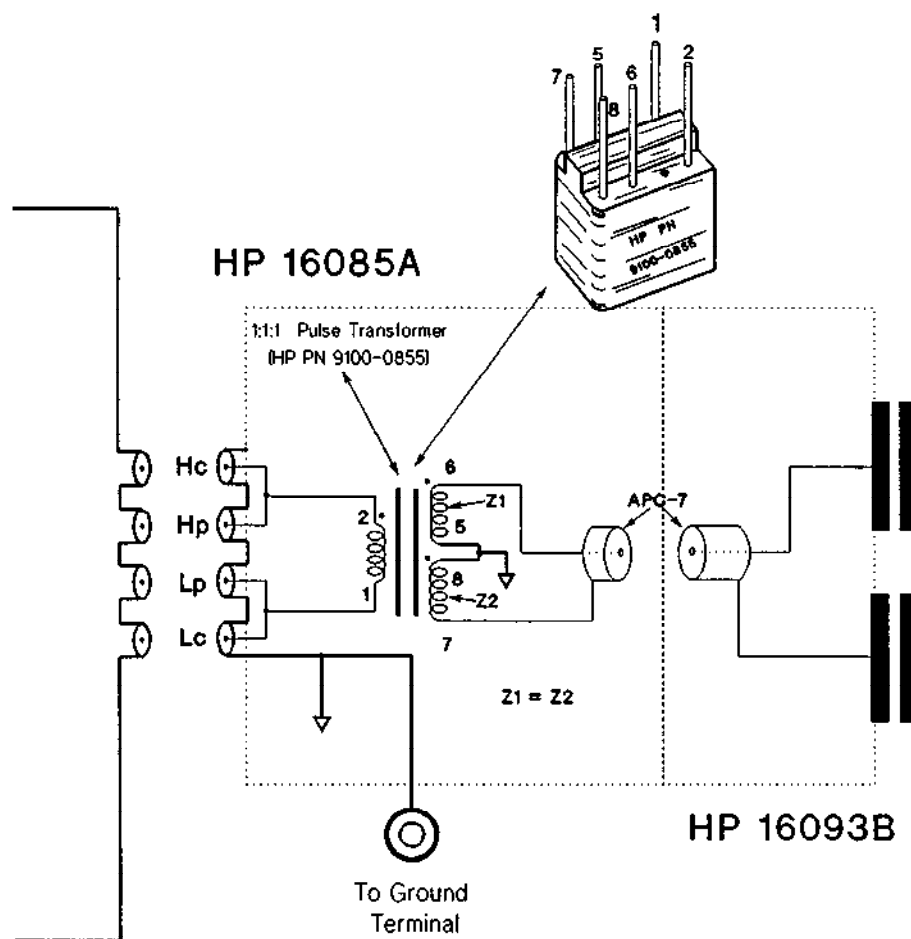

Figure 5. Using Balun Transformers

Characteristic Impedance Measurement

The frequency response of a cable is more complicated to measure when it is not infinitely long, which is always the case. Impedance mismatches between the cable and the measurement circuit will result in reflections which degrade measurement accuracy, so if the impedance of the cable differs significantly from the input impedance of the measurement instrument, and if you know the approximate impedance of the cable, use impedance matching between the input and the cable. When measuring the basic characteristics of a cable, the best way to deal with this problem is to cut the cable equal to its $1/4 \lambda$ electrical length at the sweep STOP frequency setting and measure the characteristics of the cable at the $1/8 \lambda$ frequency. This technique is most useful for basic cable characterization, but when you must know the characteristics of a cable under actual operating conditions, measure the impedance of the cable terminated with the actual termination impedance. Measure the termination impedance by itself, and then measure the terminated cable. The characteristic impedance is the square root of the product of these two measurement results. The procedure for the HP 4195A is:

1. Set up and measure the termination impedance.
2. Select the **VIEW** key and the **STORE A,B->C,D** softkey.
3. Measure the impedance terminated cable.
4. From the front panel or using **DEFINE MATH**, perform: $A=SQR(A*C)$

The **LINE CURSOR** mode and the **LCURS-->AVRG** function can be used to give the average characteristic impedance value of a sweep frequency impedance measurement. Figure 6 shows the results using this procedure.

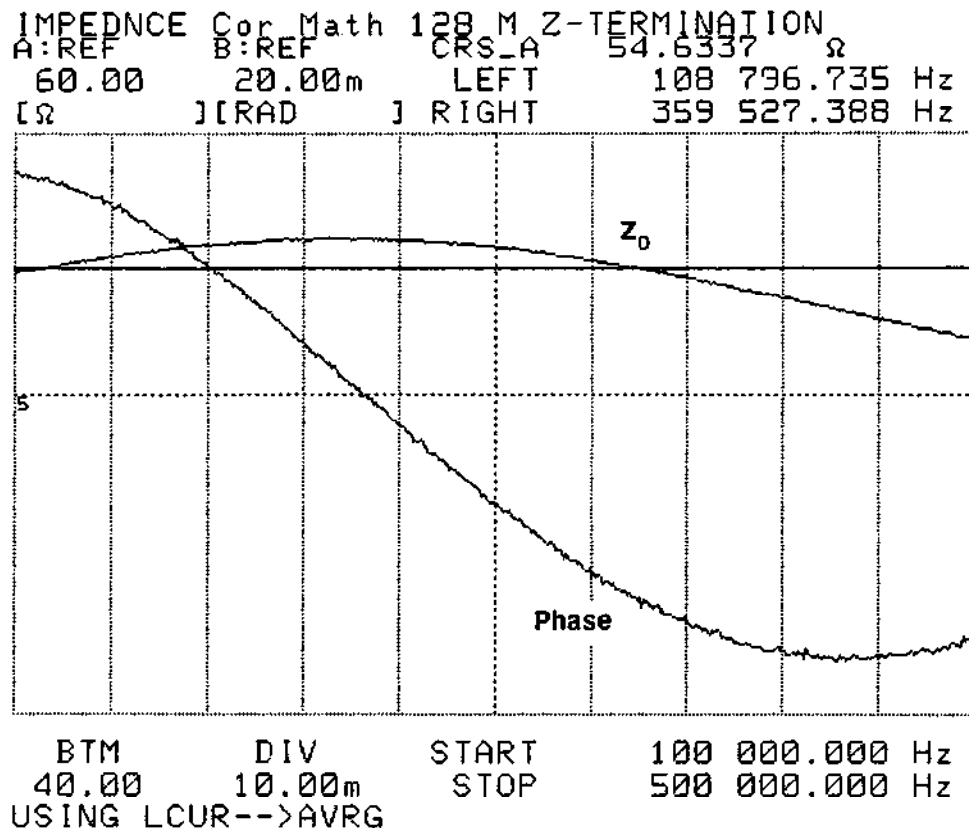

Figure 6. Finding the Average Z_0

LOCATING CABLE FAULTS

Time-Domain Reflectometry (TDR)

The *TDR* measurement technique uses a step-function test to locate cable faults by detecting and analyzing impedance discontinuities: shorts, opens, pinched cables, improper terminations, etc. *WHERE* the fault is detected, is determined by calculation using the propagation velocity of the cable and the time between the initial pulse and the impedance discontinuity reflection. The combination of horizontal and vertical response (*SHAPE*) defines *WHAT* the fault is. It is important to remember that the vertical axis is a voltage which is a function of the impedance differential between the characteristic impedance of the cable and the impedance of a discontinuity or termination.

Figure 7 shows some typical responses of basic series and shunt RC circuits (C and D) and RL circuits (A and B) which give a general representation for SHORTED, PINCHED, and OPEN type cable faults, the representation for a PINCHED cable can be any where in between the OPEN and SHORT representations. Hewlett-Packard Application Note 62 gives an excellent discussion on TDR Fundamentals and fault analysis using the HP 54120T Digitizing Oscilloscope.

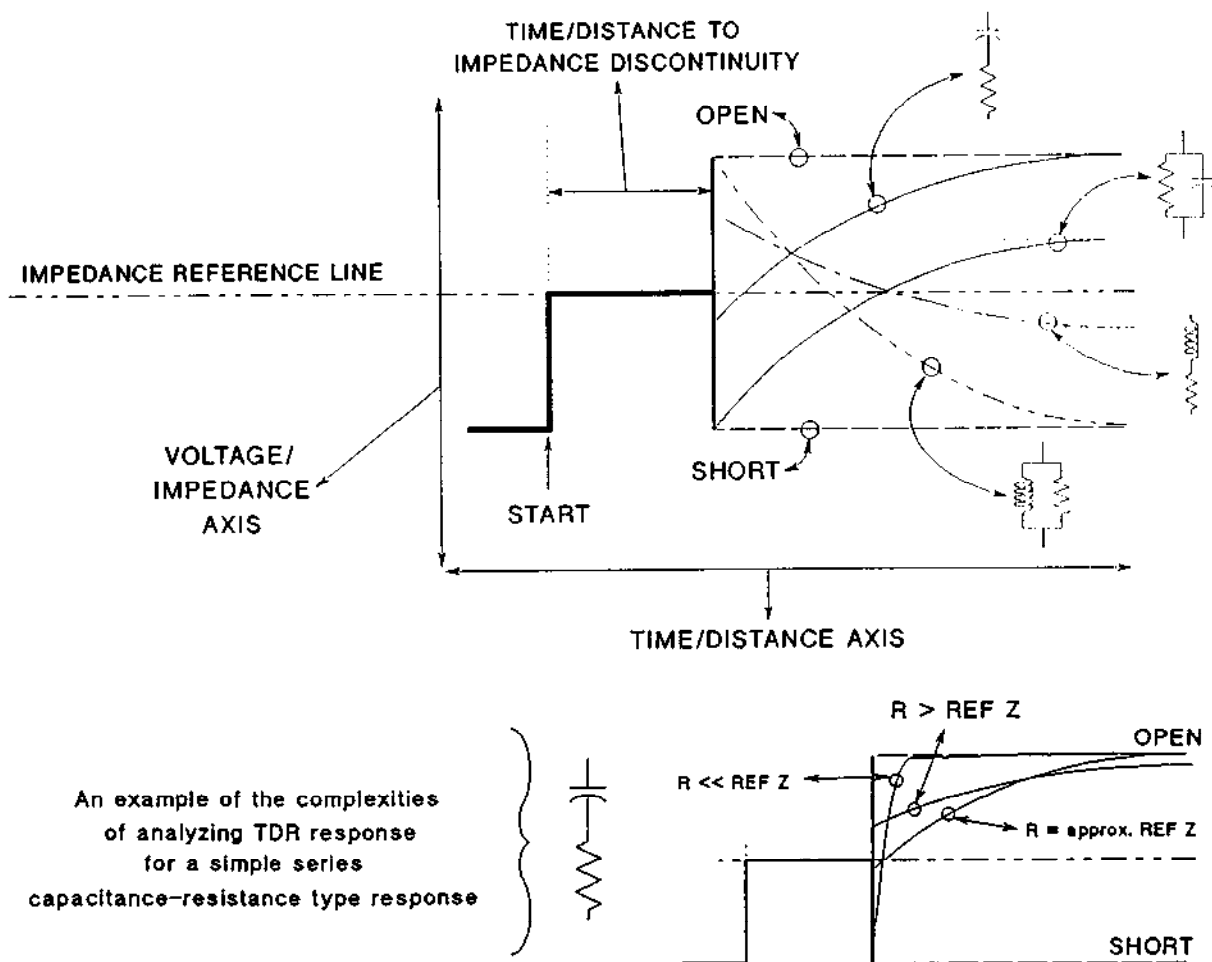

Figure 7. Interpreting TDR Measurements

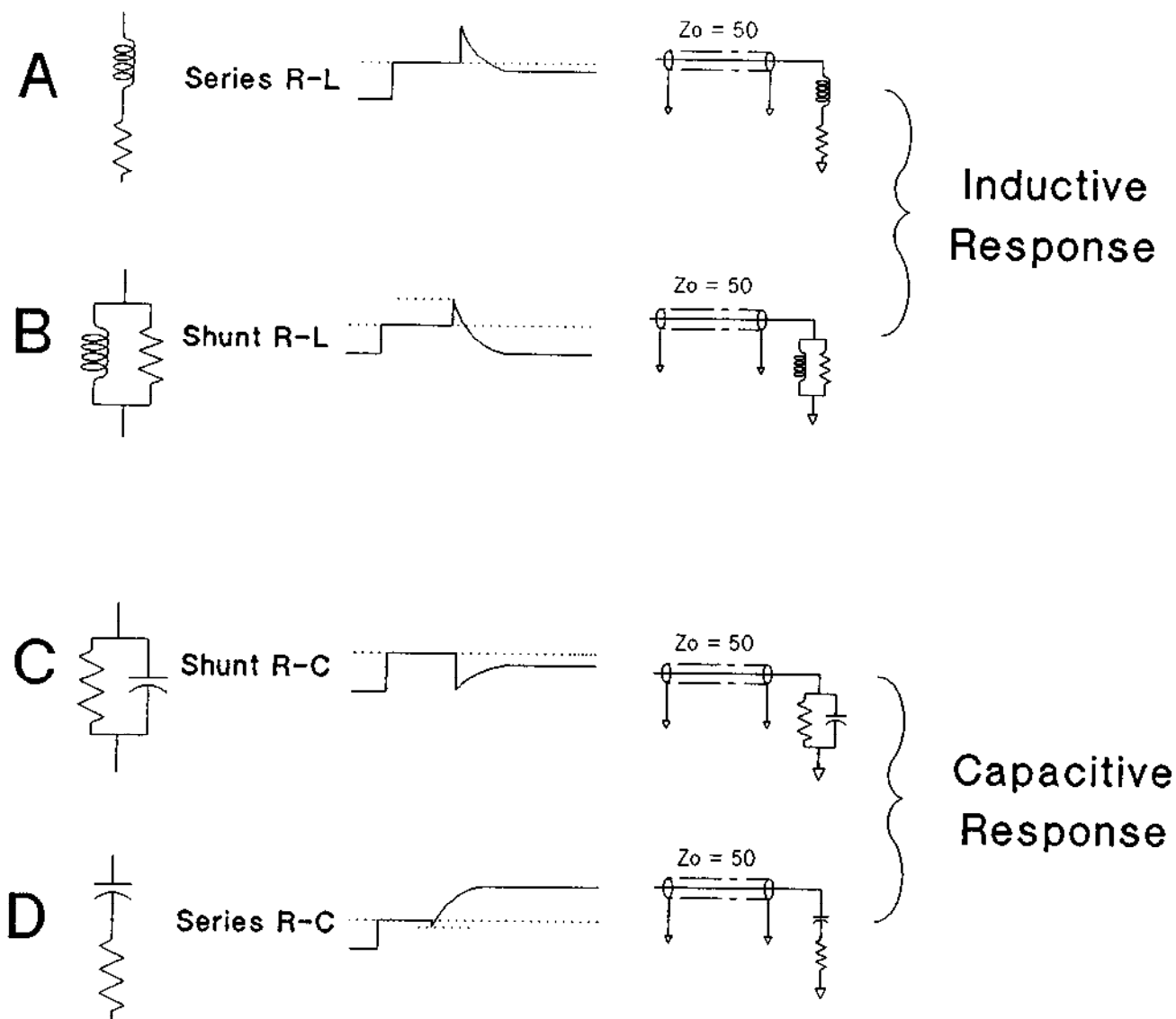

Figure 7. Interpreting TDR Measurements (*continued*)

MEASUREMENT EXAMPLES

OPEN-SHORT Measurement/Calculation to Determine Characteristic Impedance

The OPEN-SHORT measurement method of determining the characteristic impedance Z_0 and phase θ of a cable is based on the following equations:

$$|Z_0| = (|Z_{OP}| |Z_{ST}|)^{1/2} \quad \text{and} \quad \theta = (\theta_{OP} + \theta_{ST}) / 2$$

Where: $|Z_{OP}|$ = Absolute value of measured OPEN-cable impedance
 $|Z_{ST}|$ = Absolute value of measured SHORT-cable impedance

The HP 4195A Auto Sequence Program (ASP) given in Listing 1 is used to perform both the Z_0 measurement/Z-calculation, and the α and β cable constant measurement/calculations. The measurement setup and typical Z_0 measurement results are shown in Figure 8.

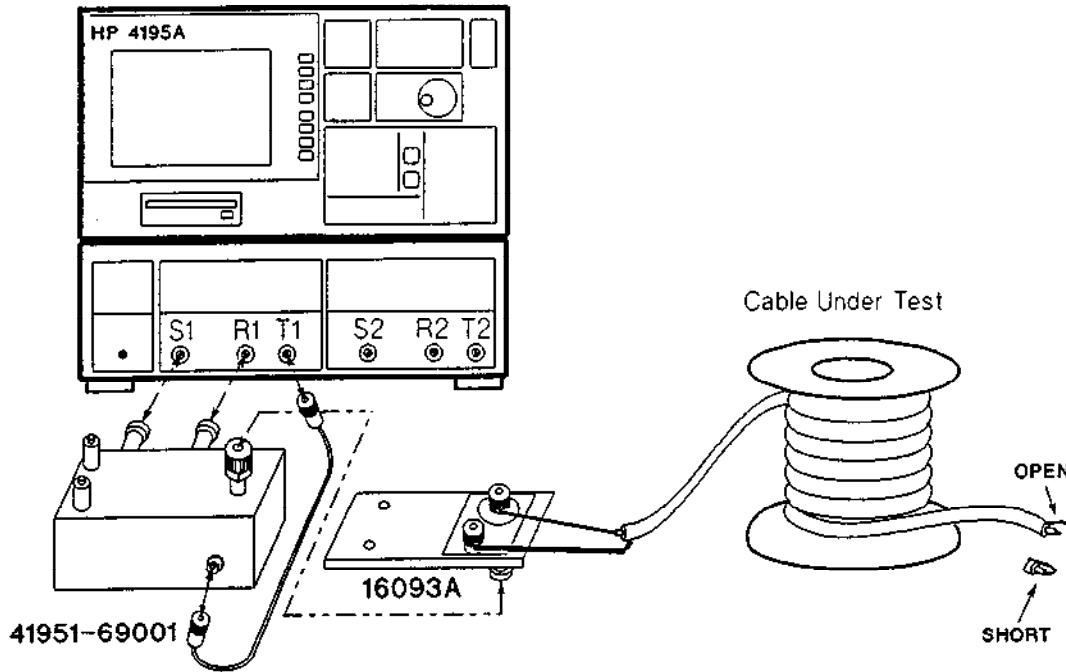

```

IMPEDNCE Cor Math CHARACTERISTIC Z VS FREQ.
A: REF      B: REF      MKR 306 288 750.000 Hz
 100.0      500.0m      Z      51.1270      Ω
 [ Ω ] [RAD ]          θ      -192.090m RAD
  
```

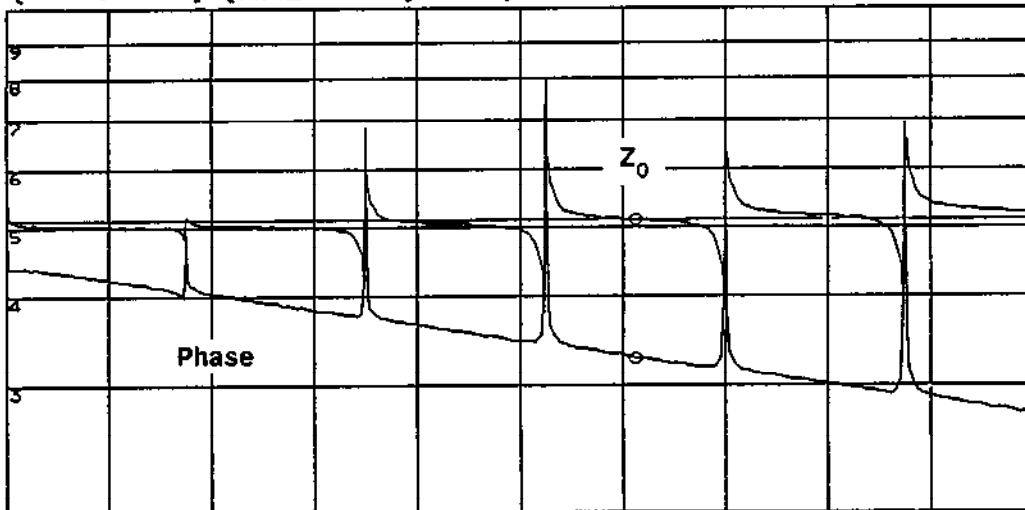

```

BTM      DIV      START      100 000.000 Hz
20.00    100.0m    STOP      500 000 000.000 Hz
RBW:     1 KHZ    ST: 4.33 sec RANGE: R=-10, T=-10dBm
  
```

Figure 8. Characteristic Impedance Measurement Setup and Results

Listing 1. HP 4195A ASP Open-Short Cable Measurement Program

```

10 FNC3
20 ! RST
30 CMT "CABLE MEASUREMENTS"
40 OSC1=-7 DBM
50 ATR1=0 DBM;ATT1=0 DBM
60 RAD
70 RBW= 1 KHZ
80 START=100 KHZ
90 ! STOP=250 MHZ
100 SCT1;SCL2;SWT1;SUM2
110 PHS2
120 DMA=MA;DMB=MB
130 UNITA=""
140 UNITB"RAD"
150 PRMA"Z";MTHA1
160 PRMB"";MTHB1
170 !
180 DISP "IS CAL NEEDED? 0=NO 1=YES"
190 PAUSE
200 IF Z=1 THEN GOSUB 2000 ! CAL
210 DISP "SET UP FOR AN OPEN-CABLE MEASUREMENT"
220 PAUSE
230 DISP "OPEN MEASUREMENT IN PROGRESS"
240 WAIT 1000
250 CMT"OPEN CABLE MEASUREMENT"
260 SWTR6
270 E=MA ! OPEN_IMPEDANCE
280 RE=MB ! OPEN_PHASE
290 SCL1;SCT2;AUTO
300 SCL2;SCT1;AUTO
310 DISP "SET UP FOR A SHORTED-CABLE MEASUREMENT"
320 SCL1
330 PAUSE
340 DISP "SHORT MEASUREMENT IN PROGRESS"
350 SWTR6
360 F=MA ! SHORT_IMPEDANCE
370 RF=MB ! SHORT_PHASE
380 AUTO
390 DISP "CHAR-Z CALCULATION IN PROGRESS"
400 !
410 CMT"CHARACTERISTIC Z VS FREQ."
420 ! CHARACTERISTIC IMPEDANCE
430 ! IS CALCULATED AS
440 !  $I = \text{SOR}(E * F)$ 
450 !
460 !
470  $I = E * F$ 
480  $A = \text{SOR}(I)$ 
490 !
500  $B = ((RE + RF)/2)$ 
510 SCL2;SCT1;AUTO
520 SCL1;SCT2;AUTO
530 MCF3;MKCR1;CRAU;SCL1
540 !
550 DISP "CHAR. Z CALCULATED USING OPEN-SHORT DATA"
560 !
570 WAIT 2000
580 DISP "YOU CAN DUMP OR PLOT THE RESULTS NOW"
590 PAUSE
600 !
610 DISP "PRESS STOP IF YOU WILL NOT MEASURE A & B"
620 WAIT 2000
630 !
640 ! ATTEN./PHASE CONSTANTS
650 !
660 CMT"A & B CABLE CONSTANTS"
670 MCF1
680 !
690 RAD
700 DISP "ATTEN./ PHASE CALCULATION IN PROGRESS"
710 RA = SQR(F/E)
720 RB = (RF-RE) / 2
730 RE = RA * COS(RB)
740 RF = RA * SIN(RB)
750  $J = (1+RE) * (1+RE) + (RF*RF)$ 
760  $H = (1-RE) * (1-RE) + (RF*RF)$ 
770 GOSUB 3000 ! __CABLE_LENGTH__
780 DISP "ATTEN. / PHASE CALCULATION IN PROGRESS"
790 E = SQR(J/H)
800 RC = (1/(Z+F)) * LN(E) * 8.6959
810 RD = (1/(Z+F)) * ((PI-ATAN((RA+1)/RB)) + ATAN((RA-1)/RB))
820 !
830 A = RC; B = RD
840 UNITA"DB/M"
850 UNITB"RAD/M"
860 PRMA"A";MTHA1
870 PRMB"B";MTHB1
880 !
890 SCL2;SCT1;AUTO
900 SCL1;SCT2;AUTO
910 MCF3;MCF4;CRAV;MKACT1;MKMX
920 DISP "MEASUREMENT COMPLETE"
930 END
940 !
950 !
2000 ! SUBROUTINE__CALIBRATION__
2010 !
2020 BEEP
2030 DISP "CONNECT 0 S"
2040 PAUSE
2050 CALT1
2060 OPNCAL
2070 DISP "CONNECT 0 OHM"
2080 PAUSE
2090 SHTCAL
2100 DISP "CONNECT LOAD"
2110 PAUSE
2120 LOCAL
2130 BEEP
2140 CORR1
2150 !
2160 !__COMPENSATION__
2170 !
2180 DISP "SETUP FOR COMPENSATION"
2190 PAUSE
2200 DISP "CONNECT 0 S"
2210 PAUSE
2220 CMPT3
2230 ZSCMP
2240 BEEP
2250 DISP "CONNECT 0 OHM"
2270 PAUSE
2280 ZOCMP
2290 BEEP
2300 CORR1
2310 DISP "CAL COMPLETE"
2320 BEEP;BEEP;BEEP
2330 WAIT 2000
2340 RETURN ! FROM CAL SUBROUTINE
2360 !
2370 !
3000 !__SUBROUTINE_CABLE_LENGTH__
3010 !
3020 !
3030 DISP "ENTER CABLE LENGTH IN METERS"
3040 PAUSE
3050 F = Z
3060 IF Z <= 0 THEN DISP "CABLE LENGTH CANNOT BE 0 OR NEGATIVE"
3070 WAIT 1500
3080 IF Z <= 0 THEN GOTO 3000 !__CABLE_LENGTH
3090 RETURN ! FROM CABLE_LENGTH SUBROUTINE

```

Measuring Cable Capacitance Using the HP 4284A

The HP 4284A makes very accurate cable capacitance measurements at frequencies up to 1 MHz. Figure 9 shows the capacitance measurement setup and Figure 10 shows some typical measurement results. The CORRECTION feature of the HP 4284A lets you correct for test fixture and measurement setup related error effects. An HP 4284A with Option 001 outputs a 20 V_{RMS} test signal for a high signal to noise ratio and gives very stable measurement results.

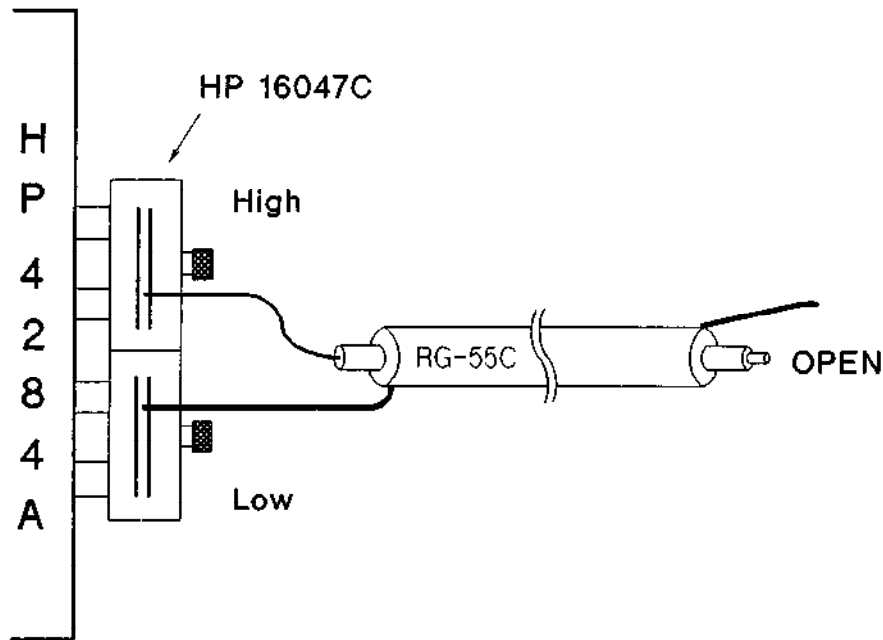

Figure 9. HP 4284A Cable Capacitance Measurement Setup

```
<MEAS DISPLAY>          SYS MENU
FUNC : Cp-D             RANGE: AUTO
FREQ : 1.00000MHz      BIAS : 0.000 V
LEVEL: 5mV             INTEG: MED

Cp : 17.2435 pF

D : .000703

Vm : 5.18mV           Im : 0.561uA
CORR: OFF
```

Figure 10. HP 4284A Cable Capacitance Measurement Results

Measuring Loss and Group Delay

Loss and group delay are easily measured using the HP 4195A network measurement function. The need to measure the group delay of a cable becomes apparent when high speed digital and analog signals are considered. Distortion caused by group delay non-uniformity is a problem at high data transfer rates. Group delay is an HP 4195A network measurement mode softkey selection, and a group delay measurement consists of selecting the T/R- τ (dB) softkey while in the NETWORK configuration and performing a THRU calibration. Figure 11 shows the network measurement setup and some typical group delay measurement results.

When phase information is not needed, loss can be measured using the built in tracking generator and spectrum analyzer function of the HP 4195A. The LOSS curve, using the sweep generator/spectrum analyzer method, is the same as the network LOSS curve shown in Figure 11. The spectrum/tracking generator method is performed as follows:

1. Select the SPECTRUM function and set the frequency and output level. Connect a cable that is much shorter than the cable to be tested between the selected output and input.
2. Make a single sweep measurement and execute $C = -A$. Connect and perform a single sweep measurement of the test cable.
3. Execute $A = A + C$ to eliminate receiver response error and attenuator switching glitches from the measurement results. Set A REF LEVEL = OUTPUT signal level and set A BOTTOM just below the lowest level measured.

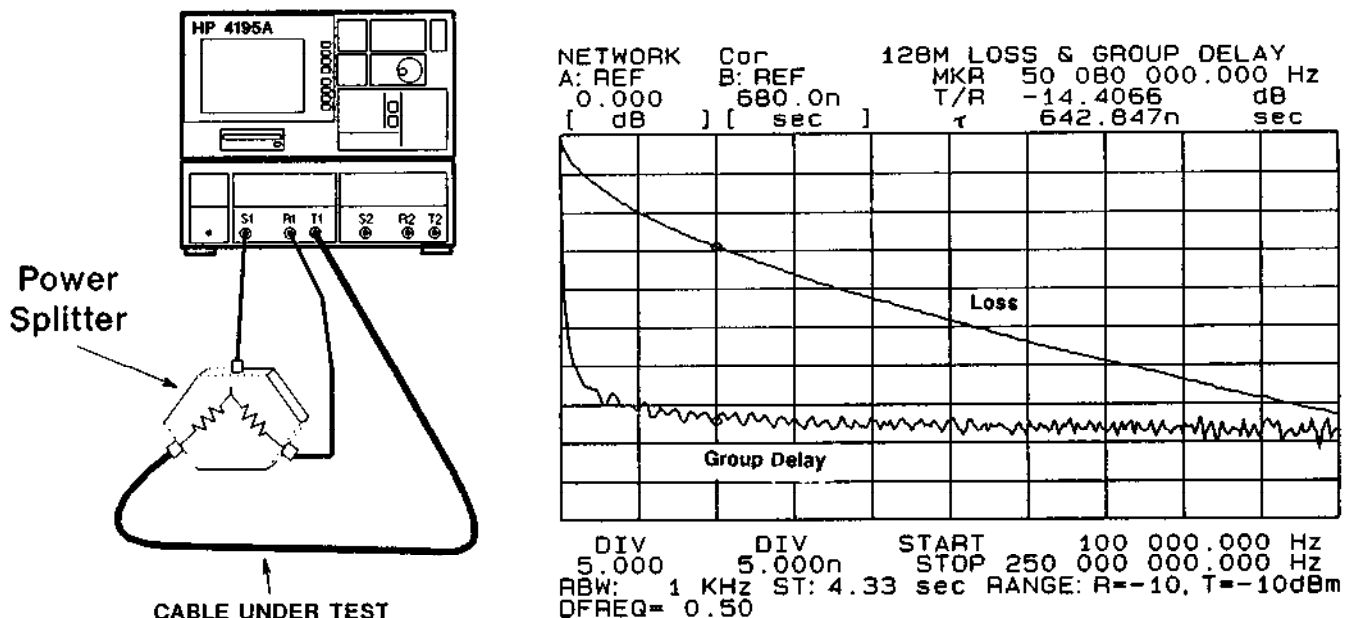

Figure 11. HP 4195A Loss and Group Delay Measurement Setup and Results

Velocity Constant

The velocity of a signal through a medium other than free space (vacuum) is less than the velocity through free space. The ratio of the non-free space velocity to the free space velocity is the *Velocity Constant*. The HP 4195A offers an easy solution to finding the real world velocity constant values, the plural "*Velocity Constants*", is used because sweep frequency measurement clearly shows that the velocity constant of a cable as a system (cable, termination, strays and residuals, etc.) is frequency dependent due to imperfections in termination impedance and cable construction. To find the *Velocity Constant* of a cable:

1. Measure the physical length of the cable.
2. Calculate the frequency for which the measured length of the cable would equal one wave length, λ_v , and label this as f_v . This calculation is based on the physical length of the cable.

$$f_v = c/\lambda_v \text{ Where: } c = 3 \times 10^8 \text{ and } \lambda_v = \text{physical length (in meters)}$$

3. Set the STOP frequency of the HP 4195A to a little higher value than frequency f_v calculated in step 2.
4. Perform a sweep frequency impedance measurement of the cable with the center conductor and shield shorted together at the end of the cable, and record the frequency of the indicated λ_1 point and label this as f_1 , see Figure 12. The frequency and λ ratios are equal.
5. Calculate f_1 / f_v (the same as λ_1 / λ_v) to obtain the propagation velocity constant of the cable for the frequency range selected.

The 1/4, 1/2, or 3/4 indicated λ frequency points should be used to derive λ , depending on which is closer to the intended frequency of use. An example is shown in Figure 13 for a 1.2 meter coaxial 50 Ω cable. The degree of difference between the 1/4, 1/2, and 3/4 λ indicated frequency points and the corresponding multiples of the 1/4 λ frequency is an indication of how good your OPEN and SHORT are. If you were using a perfect OPEN and SHORT, there would be no difference.

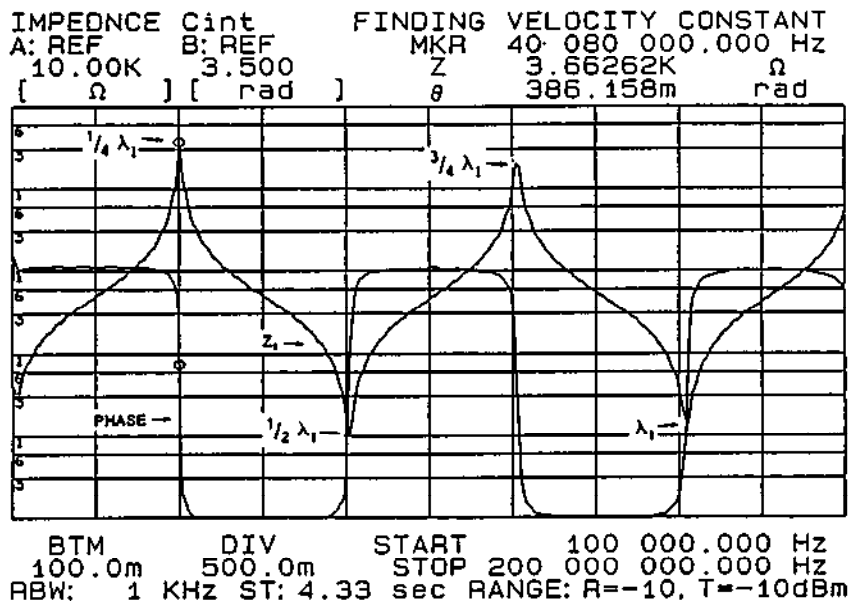

Figure 13. Finding f_1

Cable Attenuation and Phase Constants

Attenuation (α) and Phase Constants (β) are calculated using OPEN-SHORT measurement/calculated Characteristic Impedance (Z_0) and Phase (θ) data. See Figure 14 for the α and β measurement results for a 0.3 meter, N-type cable.

$$\text{Attenuation Constant: } \alpha = 8.6859 (1/2l) \ln[((1+x)^2 + y^2) / ((1-x)^2 + y^2)]^{1/2} \text{ dB/m}$$

$$\text{Phase Constant: } \beta = (1/2l) [\pi - \arctan((x+1)/y) + \arctan((x-1)/y)] \text{ rad/m}$$

Where: $x = P \cos\phi$ and $y = P \sin\phi$

and $P = \text{Calculated impedance using OPEN and SHORT measurement data}$
 $= (|Z_{OP}| |Z_{ST}|)^{1/2}$

$\phi = \text{Calculated phase using OPEN and SHORT phase measurement data}$
 $= (\theta_{ST} - \theta_{OP}) / 2$

$l = \text{Physical length in meters}$

8.6589 = Conversion factor to convert Nepiers/unit length to dBm/meter

```

IMPEDNCE Cor Math A & B CABLE CONSTANTS
A: REF      B: REF      MKR 155 069 000.000 Hz
 5.000      4.000      A      493.162m  DB/M
[DB/M ] [RAD/M ]      B      1.34701  RAD/M
  
```

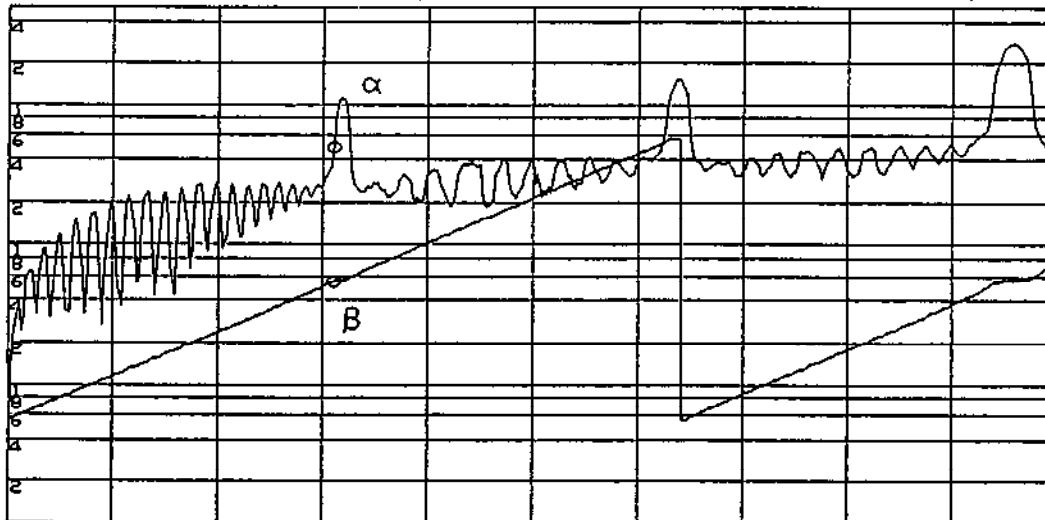

```

BTM      DIV      START      100 000.000 Hz
1.000m   500.0m   STOP 500 000 000.000 Hz
RBW: 1 KHZ ST: 4.33 sec RANGE: R=-10, T=-10dBm
  
```

Figure 14. α and β Measurement/Calculation Results

REFERENCES

Measurement setup and OPEN-SHORT-LOAD error correction are discussed in the Operation Manuals of the HP 4284A and HP 4195A. OPEN-SHORT-LOAD error correction, and impedance measurement principles and techniques are discussed in "THE IMPEDANCE MEASUREMENT HANDBOOK", HP P/N 5950-3000. The "ARRL HANDBOOK for the Radio Amateur" discusses balun transformers and transmission lines. ITT's "Reference Data for Radio Engineers" discusses transmission line theory.



United States:
Hewlett-Packard Company
4 Choke Cherry Road
Rockville, MD 20850

Hewlett-Packard Company
5201 Tollview Drive
Rolling Meadows, IL 60008

Hewlett-Packard Company
5161 Lankershim Blvd.
No. Hollywood, CA 91601

Hewlett-Packard Company
2015 South Park Place
Atlanta, GA 30339

Canada:
Hewlett-Packard Ltd.
6877 Goreway Drive
Mississauga, Ontario L4V1M8

Australia/New Zealand:
Hewlett-Packard Australia Ltd.
31-41 Joseph Street
Blackburn, Victoria 3130
Melbourne, Australia

Europe/Africa/Middle East:
Hewlett-Packard S.A.
Central Mailing Department
P.O. Box 529
1180 AM Amstelveen
The Netherlands

Far East:
Hewlett-Packard Asia Ltd.
22/F Bond Centre
West Tower
89 Queensway
Central, Hong Kong

Japan:
Yokogawa-Hewlett-Packard Ltd.
29-21, Takaido-Higashi 3-chome
Suginami-ku, Tokyo 168

Latin America:
Latin American Region Headquarters
Monte Pelvoux Nbr. 111
Lomas de Chapultepec
11000 Mexico, D.F. Mexico

March, 1990
Printed in Japan
5950-2399