

# Tutorial Description of the Hewlett-Packard Interface Bus

DESIGNED FOR  
**HP-IB**  
SYSTEMS

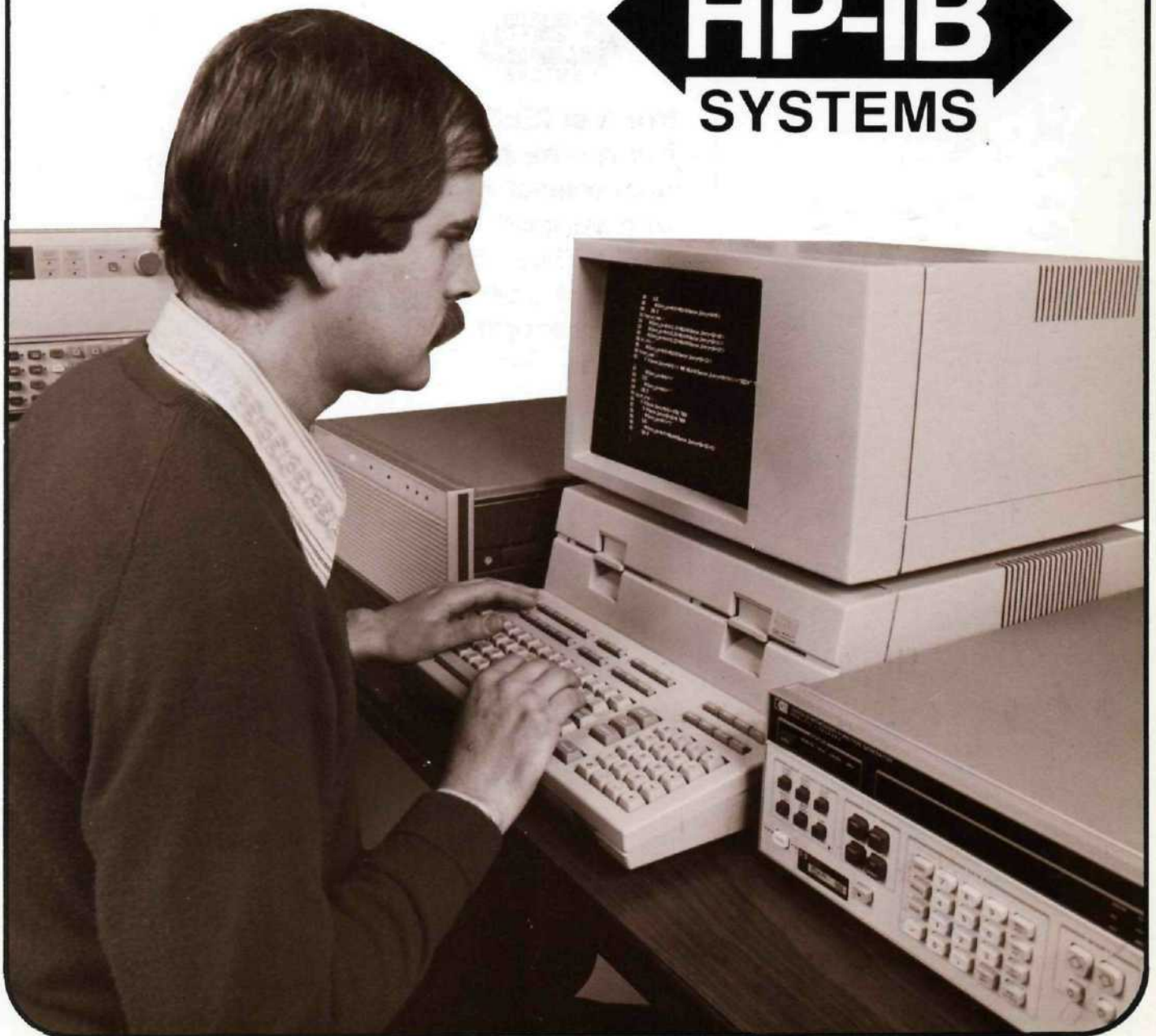



**Not just IEEE-488,  
but the hardware,  
documentation  
and support  
that delivers the  
shortest path to a  
measurement  
system.**

## Table of Contents

	Page
Foreground .....	1
Background .....	1
Status today .....	3
What comprises an interface system?.....	4
Comparing the standards .....	5
<hr/>	
 Going beyond the standards .....	7
<hr/>	
Technical overview of IEEE-488/ANSI MC1.1 .....	7
Functional aspects .....	8
Electrical aspects .....	27
Mechanical aspects (IEC-625-1 included) .....	29
Designer guidelines .....	31
Summary of 1978 revision to IEEE-488/ANSI MC1.1 .....	32
<hr/>	
“Designed for systems” aspects .....	33
Operational aspects .....	34
<hr/>	
Additional helpful HP-IB information .....	39
Suggestions for improving software performance .....	46
Generally helpful information .....	47
HP-IB configured systems .....	51
Typical factory selected HP-IB addresses .....	53
Quiz yourself .....	55

IEEE-488  
ANSI MC1.1

OVERVIEW

Interactive answers for "Quiz yourself" .....	60
Glossary of HP-IB related terms .....	64
Hewlett-Packard HP-IB bibliography .....	69
General HP-IB bibliography .....	81
Hewlett-Packard HP-IB verification programs .....	86
Appendix A Interface capability codes for Hewlett-Packard products .....	90
Appendix B ASCII/ISO and IEEE code chart .....	94

# Tutorial Description of the Hewlett-Packard Interface Bus

## Foreground

This coursebook is a tutorial description of the technical fundamentals of the Hewlett-Packard Interface Bus. It's intended to provide a thorough overview of HP-IB basics for the first-time HP-IB system designer, programmer, or user. It should be useful to instrument, computer, and system oriented engineers or technicians for either self-study, technical reference, or as an index for further research. In short, it's a broadband tutorial for learning about the Hewlett-Packard Interface Bus. A self-test is located in the rear to provide a means of measuring your performance. Let's begin with a look at what HP-IB is and where it came from . . .

## Background

The Hewlett Packard Interface Bus (HP-IB) is a carefully designed and defined general purpose digital interface system and associated support which simplifies the design and integration of instruments and computers into systems. It minimizes electrical/mechanical hardware and functional compatibility problems between devices and has sufficient flexibility to accommodate a wide and growing range of future products. As such, HP-IB is an interfacing concept, and a design technique which you can take advantage of to define, design, build, and use *your own measurement system for maximum cost-effectiveness*. It's more than an interface, it's a design philosophy . . .

HP-IB applies to the interface of instrumentation systems in which:

- (1) Data exchanged among the interconnected apparatus is digital (as distinct from analog).
- (2) Fifteen devices may be interconnected on one continuous bus.

- (3) Total transmission path lengths over the interconnecting cables does not exceed 20 meter or 2 meter per device, whichever is less (when not using a bus-extension technique).
- (4) Data rate across the interface on any signal line does not exceed 1 M byte/second.

HP-IB evolved from an internal Hewlett Packard need for a standardized instrumentation interface system. The chronology of the HP-IB evolution is summarized here:

- Sept. '65 — HP began to look at how to standardize “the interfacing of all HP future instruments.”
- March '72 — U.S. Advisory Committee (IEC) formed. The committee takes HP proposal as starting point.
- Sept. '74 — IEC approves for ballot draft document (U.S. Proposal).
- April '75 — IEEE Publishes IEEE-488.
- Jan. '76 — ANSI Publishes MC1.1.
- Nov. '78 — IEEE Revises IEEE-488.
- June '80 — IEC 625-1 published.

Initial HP design efforts beginning as early as 1965 form the interface framework which was later taken by the newly-formed International Electrotechnical Commission (IEC) Technical Committee 66, Working Group 3 as a starting proposal. By September, 1974, a draft document of the HP proposal was approved for balloting by the IEC. In April, 1975, the Institute of Electrical and Electronics Engineers (IEEE) published their document IEEE-488/1975, “Digital Interface for Programmable Instrumentation,” which contains the Electrical, Mechanical and Functional specifications of an American Standard interfacing system. The identical MC1.1 was published by the American National Standards Institute (ANSI) in January, 1976. A revision of the IEEE-488 occurred in Nov., 1978, primarily for editorial clarification and addendum. More recently (June, 1980), the IEC has published its version IEC 625-1, “An Interface System for Programmable Measuring Apparatus (Byte Serial Bit Parallel).” Then in 1982 the IEEE published IEEE-728, Recommended Practice for Code and Format Conventions for IEEE Standard 488.

## Status today

As of August, 1980, there are four major standards defining byte serial bit parallel interface systems for instrumented systems.

- 1) IEEE 488-1978
- 2) ANSI MC1.1 (Identical)
- 3) IEC 625-1 (Identical except for connector)
- 4) B.S. 6146 (British Standard—Identical to IEC 625-1)

The IEEE-488 is most widely used internationally and is implemented in several brand versions:

- HP-IB
- GPIB
- IEEE BUS
- ASCII BUS
- PLUS BUS

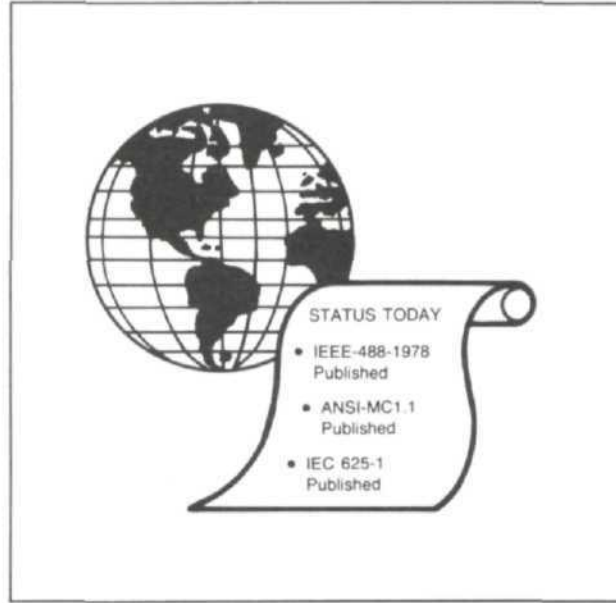

Status of standardization efforts to date

The IEEE-488 standard has been published in 9 languages and has been used by more than 250 manufacturers in more than 14 countries to design more than 2000 products\*. It is one of the most carefully defined, consistent, and highly used interface systems in the world. For example, more than 45,000 copies of IEEE-488 have been distributed as of mid 1982. Let's pause therefore to take a look at what makes it so . . .

\*Fall 1982 estimate

## What comprises an interface system?

An interface system can be totally characterized in terms of the Functional, Electrical, Mechanical, and Operational specifications of the interface.

**FUNCTIONAL** — Total set of allowable interface functions and their logic descriptions (Application independent)

**ELECTRICAL** — Logic levels, protocol, timing, termination, etc. (Application independent)

**MECHANICAL** — Connector, Mounting, Cable assembly, etc. (Application independent)

**OPERATIONAL** — Total set of allowable device functions and their logic descriptions (Applications dependent)

The IEEE-488, ANSI MC1.1, and IEC 625-1 standards address three of these areas but not the Operational area. This gives instrument and computer designers the flexibility to optimize their products to the intended applications. However, there is a document, IEEE-728-1982, which provides Code and Format Recommendations for this area.

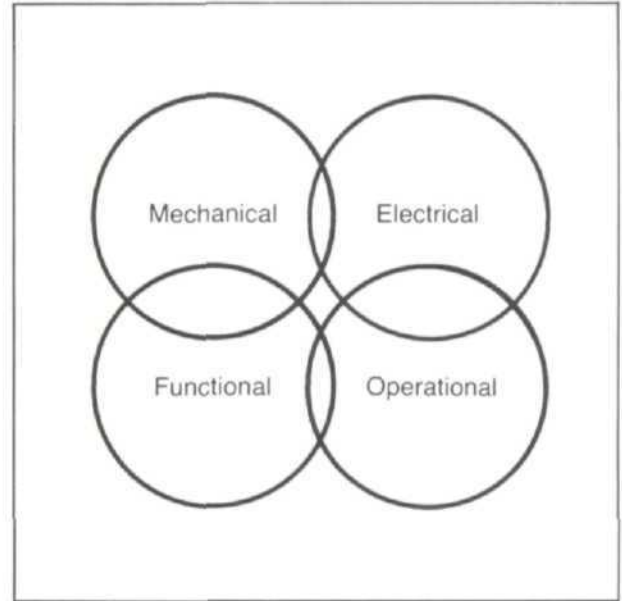

Defining an interface system

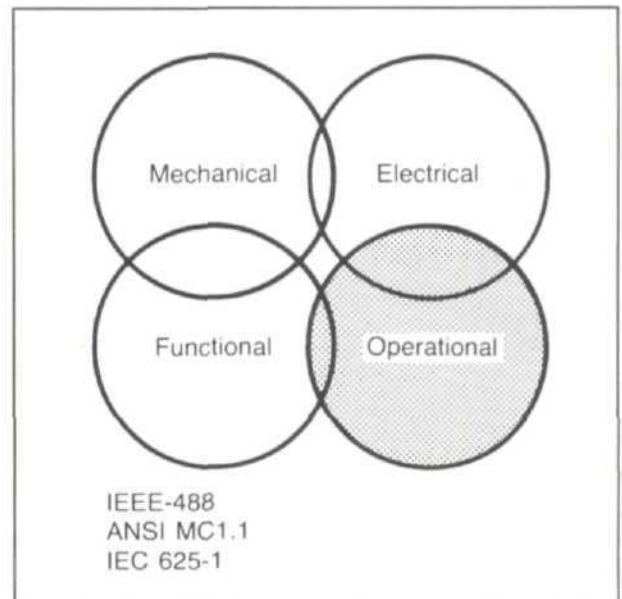

Providing design flexibility



## Comparing the standards

The IEEE-488 and ANSI MC1.1 are identical in all three of these characteristic areas.

The IEC 625-1 differs from the others in the mechanical area. This standard specifies a 25 pin D type connector rather than the 24-pin RIBBON type specified by the American Standards (Pin 25 is an extra signal return line).

Unfortunately, the 25 pin connector is used extensively as part of the Electronic Industry Association (EIA) Recommended Standard RS-232-C

“Interface Between Data Terminal Equipment and Data Communications Equipment Employing Serial Binary Data Interchange” for data communications. Signal lines utilizing this serial scheme employ voltage levels up to  $\pm 25V$  with .5 ampere short-circuit current

capabilities. Connecting an RS-232-C circuit to an IEC 625-1 instrument will cause circuit damage.

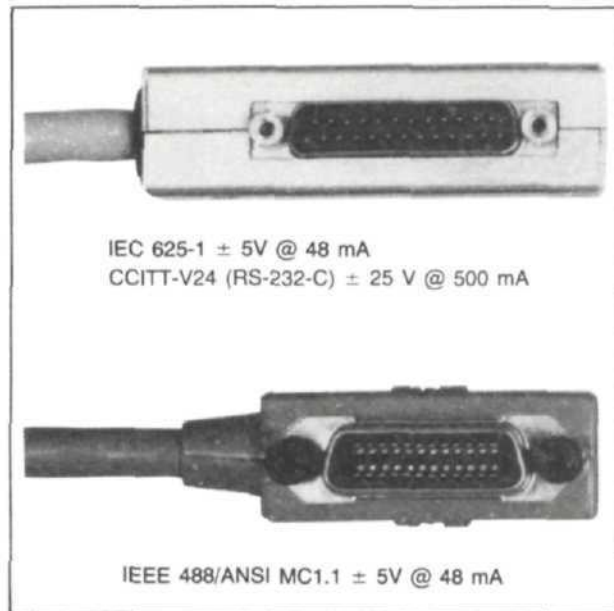

IEC vs. IEEE/ANSI connector distinction

### CAUTION

Component damage, due to incompatible voltage levels, is possible if data communication and instrumentation interfaces are inadvertently interconnected (IEC 625-1 compatible device to an RS-232-C compatible interface). Any mechanical specification difference between the IEEE-488/ANSI MC1.1 and IEC 625-1 standards may be accommodated by a simple (physical) adaptor assembly when products implemented from the two standards are interconnected.

In Europe about 90% of the bus-compatible products presently prefer or offer the IEEE-488/ANSI MC1.1 connector. Many of the manufacturers offer the option of either type and there are simple adaptors on the market.

The following information will help you obtain your own copies of the interface standards just discussed.

Ordering Interface Standards			
			
IEEE	ANSI	IEC	EIA
<u>IEEE 488-1978</u>	<u>ANSI MC1.1</u>	<u>IEC 625-1</u>	* <u>EIA RS-232-C</u>
"Digital Interface for Programmable Instrumentation"	"Digital Interface for Programmable Instrumentation"	"An Interface System for Programmable Measuring Apparatus (Byte Serial Bit Parallel)"	"Interface Between Data Terminal Equipment and Communication Equipment Employing Serial Binary Data Interchange"
<u>IEEE STANDARDS</u>	<u>ANSI STANDARDS</u>	<u>IEC STANDARDS</u>	<u>EIA STANDARDS</u>
345 E. 47th Street New York, New York 10017 Price: \$9.50 (U.S.)	1430 Broadway New York, New York 10018 Price: \$10.00 (U.S.)	1, rue de Varembe 1211 Geneva 20 Switzerland Price: 150 Swiss Francs	2001 Eye St. N.W. Washington, D.C. 20006 Price: \$5.10 (U.S.)

\*recommended companion document "Industrial Electronics Bulletin No. 9 — Application Notes for EIA Standard RS-232-C" (\$2.60 in U.S.)

Further information from Hewlett Packard is described in the INTERNAL BIBLIOGRAPHY near the end of this handout.

Further information from other sources is described in the EXTERNAL BIBLIOGRAPHY near the end of this handout.

## HP-IB: Going beyond the standards

The Hewlett Packard Interface Bus (HP-IB) begins by being totally consistent with all Electrical, Mechanical, and Functional specifications of the IEEE 488/ANSI MC1.1 standards. It also is totally consistent with the Electrical and Functional specifications of the IEC 625-1 standard. Hewlett Packard's experience designing HP-IB system components leads to additional "Designed for Systems" benefits in the operational area of HP-IB products/systems and in the programmer/user conveniences engineered into them. First, a technical overview of HP-IB . . .

### Technical overview of IEEE 488/ANSI MC1.1

The key specifications of HP-IB are summarized here:

- INTERCONNECTED DEVICES — Up to 15 maximum on one contiguous bus.
- INTERCONNECTION PATH — Star or linear bus network up to 20 meters total transmission path lengths.
- SIGNAL LINES — Sixteen active total; 8 data lines and 8 lines for interface and communication management.
- MESSAGE TRANSFER SCHEME — Byte-serial, bit-parallel, asynchronous data transfer using interlocking three-wire handshake technique.
- MAXIMUM DATA RATE — One megabyte per second over limited distances; 250 to 500 kilobytes per second typical maximum over a full transmission path. The actual data rate is determined by the devices in communication at the time.
- ADDRESS CAPABILITY — Primary addresses, 31 Talk and 31 Listen; *secondary (2-byte)* addresses, 961 Talk and 961 Listen. There can be a maximum of 1 Talker and up to 14 Listeners at a time on a single bus.
- PASS CONTROL — In systems with more than one controller, only one can be active at a time. The currently active controller can pass control to one of the others. Only the controller designated as system controller can assume control.
- INTERFACE CIRCUITS — Driver and Receiver circuits TTL and Schottky compatible.

## Functional aspects

The HP-IB interface system utilizes a party-line bus structure (devices share signal lines) to which a maximum of 15 devices may be connected in one contiguous bus. Sixteen signal lines and 8 ground lines are used to interconnect devices in a parallel arrangement and maintain an orderly flow of device and interface related information.

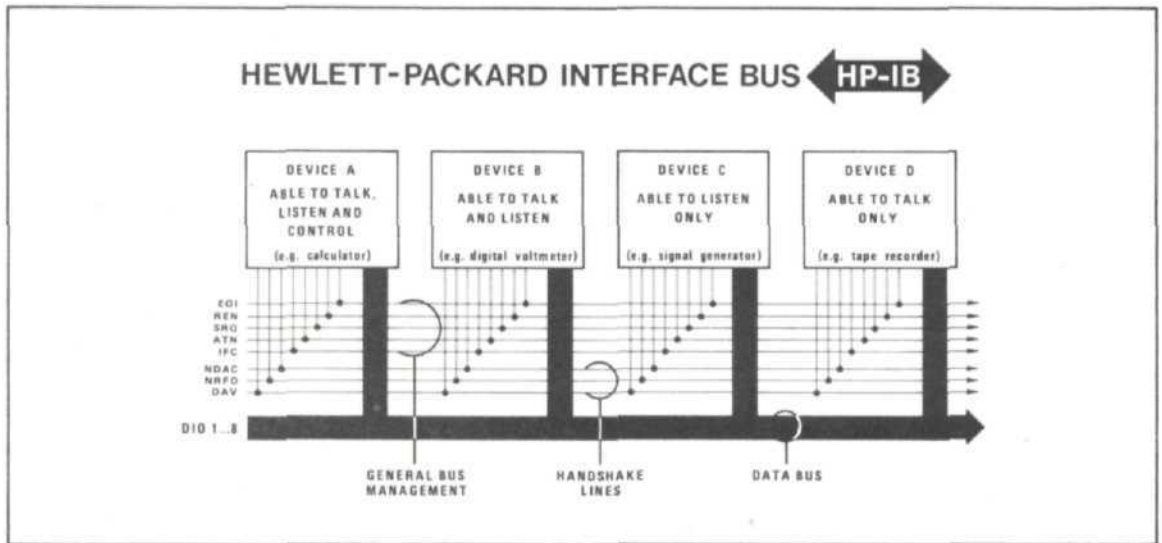

Structure of the HP-IB

Every HP-IB device must be capable of performing one or more of the following interface functions (roles):

- LISTENER** — A device capable of receiving data over the interface when addressed. Examples of this type of devices are: printers, display devices, programmable power supplies, programmable signal sources and the like. There can be up to 14 active listeners simultaneously on the interface.
- TALKER** — A device capable of transmitting data over the interface when addressed. Examples of this type of devices are: tape readers, voltmeters that are outputting data, counters that are outputting data, and so on. There can be only one active talker on the interface at a time.
- CONTROLLER** — A device capable of this includes specifying the talker and listeners for an information transfer (including itself). A computer with an appropriate I/O card is an example of this type of device. There can be only one active controller on the interface at a time. In multiple controller systems only one can be a **SYSTEM CONTROLLER (MASTER)**.

## INTERFACE FUNCTIONS

Interface functions are predefined capabilities which could be designed into an HP-IB device. **The designer is free to choose which are implemented in a device depending on the particular device's intended application.** The total available set is summarized here. See also Appendix A.

Available Interface Functions

Interface Functions that may be included in an HP-IB device.	Mnemonic	Comments
Talker or Extended Talker	T,TE	Capability required for a device to be a "talker".
Listener or Extended Listener	L,LE	Capability required for a device to be a "listener".
Source Handshake	SH	This provides a device with the capability to properly transfer a multiline message.
Acceptor Handshake	AH	This provides a device with the capability to guarantee proper reception of remote multiline messages.
Remote/Local	RL	Provides capability to select between two sources of input information. Local corresponds to front panel controls and remote to the input information from the bus.
Service Request	SR	This capability permits a device to asynchronously request service from the controller.
Parallel Poll	PP	Provides capability for a device to uniquely identify itself if it requires service when the controller is requesting a response.  This capability differs from service request in that it requires a commitment of the controller to periodically conduct a parallel poll.
Device Clear	DC	This function allows a device to be initialized to a pre-defined state. A device with this capability will have the effect of this command described in its operating manual.

### Available Interface Functions (continued)

Interface Functions that may be included in an HP-IB device.	Mnemonic	Comments
Device Trigger	DT	This function permits a device to have its basic operation initiated by the talker on the Bus.
Controller	C	This function permits a device to send addresses, universal commands and addressed commands to other devices on the HP-IB. It may also include the ability to conduct polling to determine devices requiring service.
Drivers	E	This code describes the type of electrical drivers used in a device.

The HP-IB interface bus signal lines all use a low-true logic convention with positive polarity and are grouped into three sets:

a. **DATA LINES**—An 8-bit bidirectional bus is used to transfer information from device to device on the interface. Normally, a 7-bit ASCII (American Standard Code for Information Interchange) code. The international equivalent to this is the 7-bit ISO (International Standards Organization) code. However, other encoding techniques may be utilized to compress information on these 8 lines. Information transferred includes interface commands, addresses, and device dependent data (discussed later with the ATN management line).

The transfer of the 3 byte sequence "BUS" would occur as shown here over the Data Lines. Hence the **BIT PARALLEL . . . BYTE SERIAL** description.

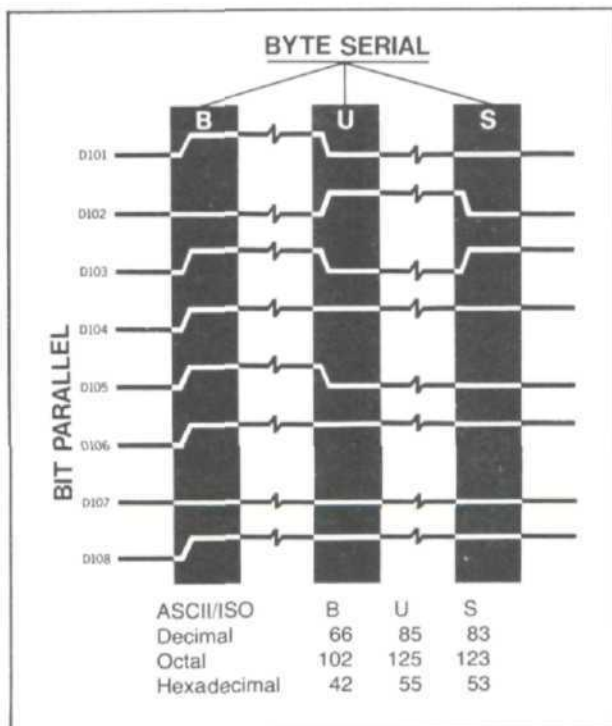

Data bus format

b. **HANDSHAKE LINES** — 3 lines used to coordinate the transfer of data over the data bus from a source (an addressed talker or a controller) to an acceptor (an addressed listener or all devices receiving interface commands) to ensure data transfer integrity. This technique has the following characteristics:

1. Data transfer is asynchronous and the transfer rate automatically adjusts to the speed of the sender and receiver(s) and runs at the rate of the slowest addressed device.
2. More than one device can accept data at the same time.
3. Every byte transferred undergoes the handshake (except for parallel poll response).
4. When universal commands are sent over the data bus, the slowest device on the bus will determine the transfer rate during the transfer of that command.
5. The actual transfer rate of the data is also affected by the time it takes the instrument to take the reading and the time necessary for the controller to input the information.

NOTE
------

HP-IB signal lines use a low-true logic convention to implement the wired or convention of the NRFD and NDAC lines, provide active true-state assertion, and reduce noise susceptibility in the true state.

The three handshake lines are:

**DAV** — Data Valid. Used to indicate the condition of the information on the D I/O lines. Driven (low) by the source when data is settled and valid and NRFD (high) has been sensed.

**NRFD** — Not Ready For Data. Used to indicate the condition of readiness of device(s) to accept data. Acceptor sets its NRFD (low) to indicate it is not ready to accept data. It releases this line when it is ready to accept data. However, the NRFD line to the talker will not go high until all addressed listeners are ready to accept data.

**NDAC** — Not Data Accepted. Used to indicate the condition of acceptance of data by device(s). The acceptor will set its NDAC (low) to indicate it has not accepted data. When it accepts data from the D I/O lines, it will release its NDAC line. However, the NDAC line to the talker will not go high until the last/slowest listener has accepted the data.

The handshake timing sequence is illustrated in the following figure:

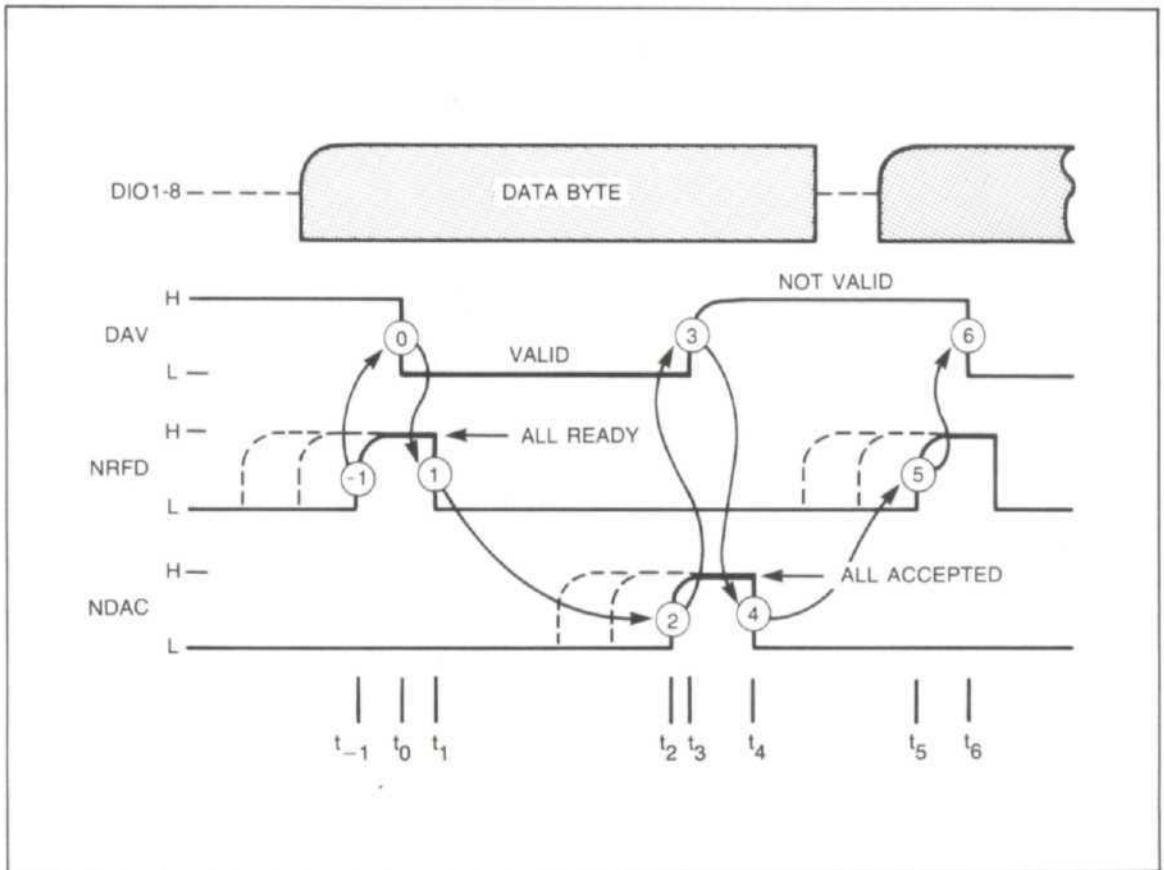

Data byte transfer

Preliminary: Source checks for listeners and places data byte on data lines.

$t_{-1}$ : All acceptors become ready for byte. NRFD goes high with slowest one.

$t_0$ : Source validates data (DAV low)

$t_1$ : First acceptor sets NRFD low to indicate it is no longer ready for a new byte.

$t_2$ : NDAC goes high with slowest acceptor to indicate all have accepted the data.

$t_3$ : DAV goes high to indicate this data byte is no longer valid.

$t_4$ : First acceptor sets NDAC low in preparation for next cycle.

$t_5$ : Back to  $t_{-1}$  again.



The handshake sequence is depicted in flowchart form below:

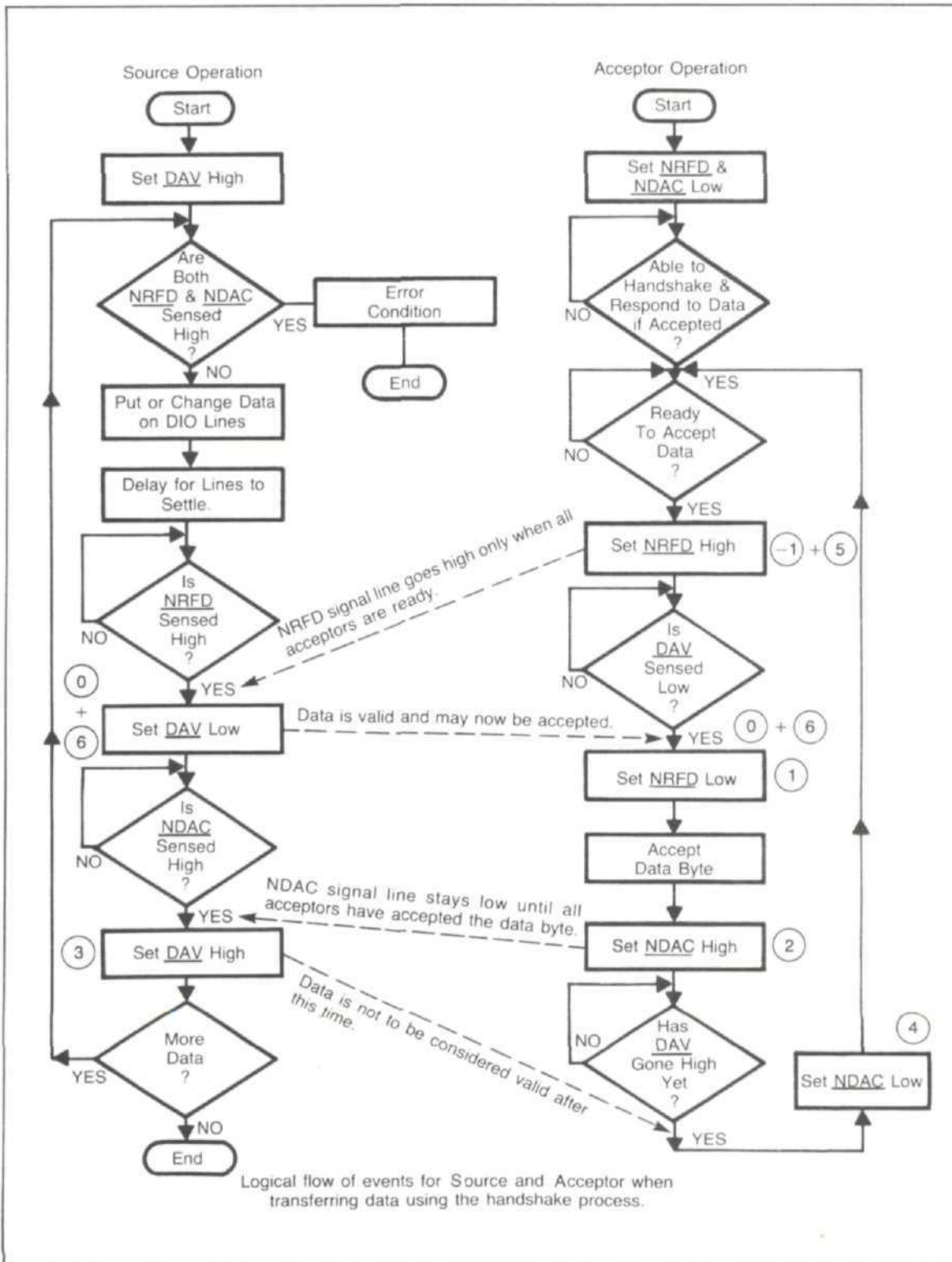

Handshake timing sequence

Hewlett-Packard's patent position on the three-wire handshake technique:

### THREE-WIRE PATENT POSITION

- One Time Charge \$250
- Company and All Subsidiaries
- No Disclosure Required
- Eight Patents Issued:
  - U.S.A.
  - Germany
  - Holland
  - France
  - Italy
  - Switzerland
  - United Kingdom
  - Japan

Patent position on three-wire handshake

### TYPICAL QUESTIONS AND ANSWERS

**Question:** Why does HP-IB use a Low True Logic Convention?

**Answer:** To facilitate the wired-OR (logical-AND) use of the NRFD and NDAC lines, reduce noise susceptibility in the true state, and provide a low power passive false condition (HIGH) on the lines when not in use or disconnected.

**Question:** Why are 3 wires required for a simplex type of communication?

**Answer:** To ensure data integrity in a multiple listener (one fast, one slow) transaction. A GATE-FLAG (2-wire) type handshake might allow multiple acceptance of the same ASCII character.

**Question:** What about drivers? Terminations?

**Answer:** Open-collector drivers are typically used but tristate drivers are also allowed (speed advantage). The small signal AC  $Z_{in}$  (a standard load) is  $<2K$  in parallel with  $\leq 100pf$  @ 2V measured at 1 MHz.

General Interface Management Lines — These 5 lines are used to manage an orderly flow of information across the interface:

NAME	MNEMONIC	DESCRIPTION
ATTENTION	ATN	CAUSES ALL DEVICES TO INTERPRET DATA ON THE BUS AS A CONTROLLER COMMAND AND ACTIVATE THEIR ACCEPTOR HANDSHAKE FUNCTION (COMMAND MODE) OR DATA BETWEEN ADDRESSED DEVICES (DATA MODE).
INTERFACE CLEAR	IFC	INITIALIZES THE HP-IB SYSTEM TO AN IDLE STATE (NO ACTIVITY ON THE BUS).
SERVICE REQUEST	SRQ	ALERTS THE CONTROLLER TO A NEED FOR COMMUNICATION.
REMOTE ENABLE	REN	ENABLES DEVICES TO RESPOND TO REMOTE PROGRAM CONTROL WHEN ADDRESSED TO LISTEN.
END OR IDENTIFY	EOI	INDICATES LAST DATA BYTE OF A MULTIBYTE SEQUENCE; ALSO USED WITH ATN TO PARALLEL POLL DEVICES FOR THEIR STATUS BIT.

General interface management lines

**ATN (ATTENTION)**

All devices must monitor ATN at all times and respond to it within 200 ns. When true, ATN places the interface in the "COMMAND MODE" where all devices accept (handshake) data on the Data Lines and interpret it as COMMANDS or ADDRESSES.

When false, ATN places the interface in the "DATA MODE" where the active talker sources device dependent DATA to all active listeners.

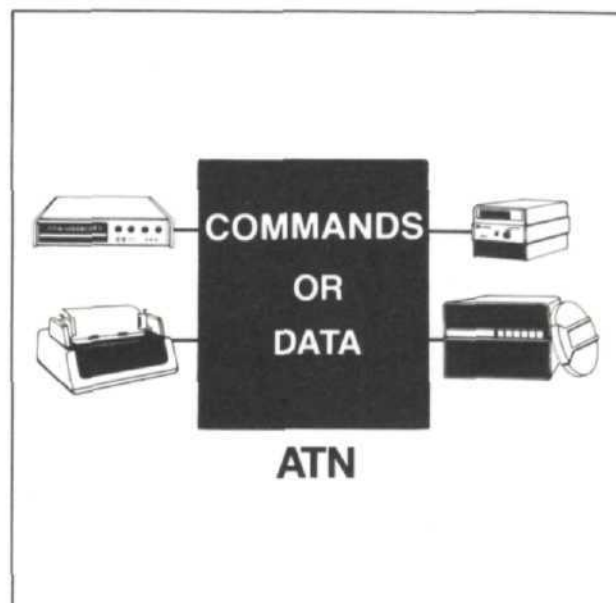

## COMMAND MODE (ATN true)

The commands serve several different purposes:

1. Talk or listen addresses select the instruments that will source and accept data. They are all multiline messages (i.e., messages sent over the data bus). Addresses are sent to all devices.
2. Universal commands cause every instrument so equipped to perform a specific interface operation. They include five multiline commands and four uniline commands, interface clear (IFC), remote enable (REN), attention (ATN), and identify (IDY) where both ATN and EOI are true.
3. Addressed commands are similar to universal commands, except that they affect only those devices that are addressed and are all multiline commands. An instrument responds to an addressed command, however, only after a controller has already told it to be a listener.
4. Secondary commands are multiline messages that are always used in conjunction with an address, universal command, or addressed command (also referred to as primary commands) to provide additional command codes. Thus they extend the code space when necessary.

## TALK AND LISTEN . . . ADDRESSES

Every HP-IB device has at least *one*\*. Device Addresses are used by the active controller in the COMMAND MODE to specify who talks (via a Talk Address) and who listens (via Listen Addresses). A device's address is usually pre-set at the factory and is resettable during system configuration by an address switch, jumpers, or front panel entry. This switch is typically located on the outside rear panel of the device but could be internal. The decimal equivalent of the 5 least significant bits of this switch determines the device's address on the interface and can be from 0 to 30 inclusive. Any given Device Address can specify two corresponding address codes on the Data Lines (although it may only actually respond to one):

1. A Talk Address
2. A Listen Address

The sixth and seventh bits (DIO6-DIO7) are used to distinguish between a device's talk and listen address characters. (High-level I/O drivers typically configure these two bits for you.) Changing a device's address switch changes both. Two address codes are used to tell every device to UNTALK (–) or UNLISTEN (?). Therefore device address 31 is illegal and the maximum useable set totals 31 (zero base). Controllers usually treat HP-IB addresses via global variables, common memory, Logical Unit (LU) numbers, or symbol tables so that address changes require minimal program modification. Let's try an example.

\*Unless it's totally transparent or a Talk or Listen Only device.

Say you wish to set a COUNTER for an HP-IB address of decimal 25 . . .

Decimal 25 corresponds to binary 11001 or octal 31. Locating the address on the back of the instrument, you set switches A1, A4, and A5 to "1" and switches A2 and A3 to "0".

Address Switch Numbers					Address Characters		Octal Value	5-Bit Decimal Value
5	4	3	2	1	Talk	Listen		
0	0	0	0	0	@	SP	00	00
0	0	0	0	1	A		01	01
0	0	0	1	0	B	"	02	02
0	0	0	1	1	C	#	03	03
0	0	1	0	0	D	\$	04	04
0	0	1	0	1	E	%	05	05
0	0	1	1	0	F	&	06	06
0	0	1	1	1	G	'	07	07
0	1	0	0	0	H	(	10	08
0	1	0	0	1	I	)	11	09
0	1	0	1	0	J	*	12	10
0	1	0	1	1	K	+	13	11
0	1	1	0	0	L	,	14	12
0	1	1	0	1	M	-	15	13
0	1	1	1	0	N	.	16	14
0	1	1	1	1	O	/	17	15
1	0	0	0	0	P	0	20	16
1	0	0	0	1	Q	1	21	17
1	0	0	1	0	R	2	22	18
1	0	0	1	1	S	3	23	19
1	0	1	0	0	T	4	24	20
1	0	1	0	1	U	5	25	21
1	0	1	1	0	V	6	26	22
1	0	1	1	1	W	7	27	23
1	1	0	0	0	X	8	30	24
1	1	0	0	1	Y	9	31	25
1	1	0	1	0	Z	:	32	26
1	1	0	1	1		:	33	27
1	1	1	0	0	\	<	34	28
1	1	1	0	1		=	35	29
1	1	1	1	0	^		36	30
1	1	1	1	1	~	?	37	31

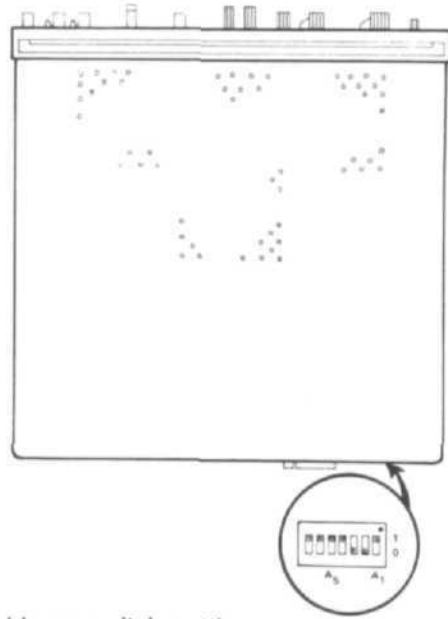

Controller

← Address switch settings

Talk and listen addresses

- 1) Computer interface card, factory set TALK/LISTEN address (not advisable for use as an instrument address).
- 2) 31 is not an address but "untalk" or "unlisten."

A close-up on the COUNTER and address switch . . .

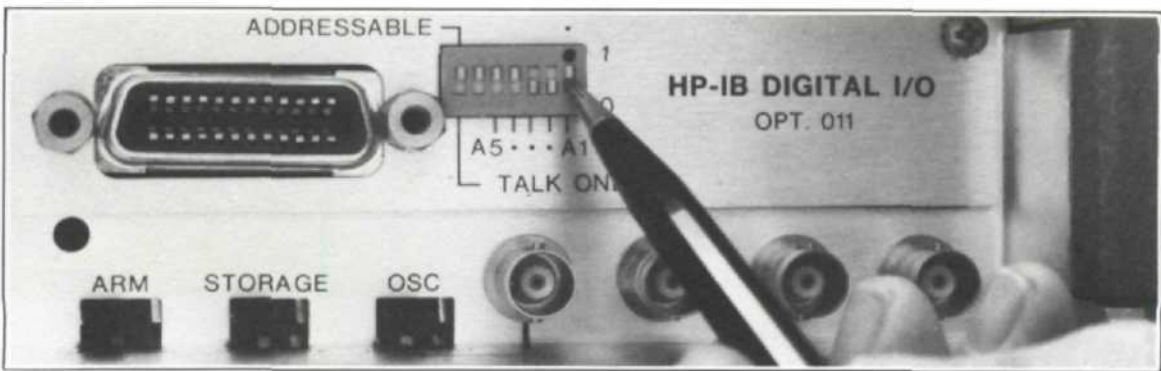

## ATN

The remaining switches on some devices (A6 and A7, etc.) are typically used to establish the device in Talk or Listen Only modes or to implement self-test features such as Signature Analysis or other service aids. Talk or Listen Only switches can be set to activate a talker or listeners without controller addressing (a controller-less system).

**EXTENDED ADDRESSING** — HP-IB devices with EXTENDED ADDRESSING capabilities (secondary commands) recognize an additional address character to establish some lower-level identity (a particular card or register in the device) as a talker or listener. Extended Talker and Listener capabilities are mutually independent in a device (e.g. you could have an HP-IB device which is an Extended Talker but only a Basic Listener, etc.).

**MULTIPLE ADDRESSES** — HP-IB devices with multiple device capabilities which can be treated individually (e.g. Plotter/Printers, etc.) may have more than one talk or listen address (as opposed to extended addresses).

Multiple-address devices typically use fewer switch address switches — 2 addresses require just four switches. A single setting will determine two talk addresses and two listen addresses. Four switches would control the A2 through A5 positions. (There is no switch for A1.) Setting these switches to a value of one produces two listen addresses of "2" and "3" in ASCII with two corresponding talk addresses of "R" and "S". Refer to the ASCII/ISO and IEEE code chart in Appendix A.

A5	A4	A3	A2	A1	(Notice no A1, therefore, switches are set for decimal 18, 19 or octal 22, 23)
1	0	0	1	—	

Example setting for dual-address device

## A PRIMER ON INTERFACE ADDRESSING

Each HP-IB computer interface will have a select code which allows the computer to access it and distinguish it from other interfaces in your system. The technique used to assign an interface address to an interface will vary from computer to computer (computer DEPENDENT). Here are 2 common techniques:

### SELECT CODES—

Many Desktop Computers treat each interface card as a Select Code which can be physically set on the interface card by a switch or jumpers. You may have to go inside the interface card or computer to set the select code. The interface card may also have a switch or jumpers to establish its HP-IB device address, e.g., 21 (since it is also a device on the HP-IB). Don't confuse these two distinct addresses.

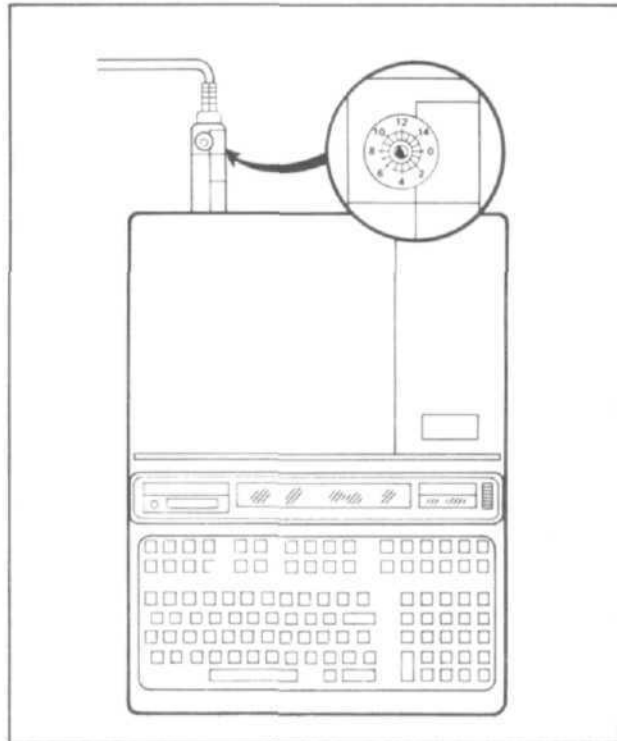

One form of Interface addressing  
on a desktop computer  
(Select Codes)

**LOGICAL UNITS —** Many Minicomputers treat each interface as a Logical Unit (LU) number which is assigned by system software to the interface through a device reference table (DRT). The DRT points to an entry in an Equipment Table (EQT) which specifies the I/O slot\*, name of driver, and other I/O information. This table is set up for a particular interface and is also used to equate available LU numbers with Device Addresses on that interface. HP-IB control is therefore accomplished via one LU to the interface (DIRECT I/O) or N LU's to N devices (AUTO ADDRESSING).

\*Which is analogous to a Select Code.

A typical HP-IB addressing structure using LU numbers would be:

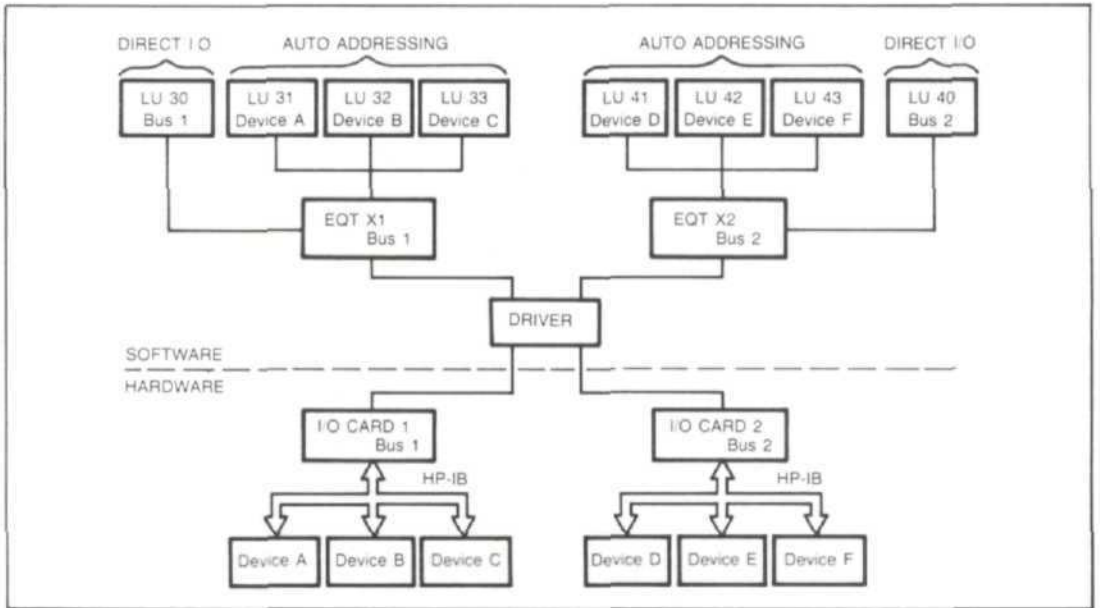

HP-IB addressing in a minicomputer (Logical Units)

Although hardware-wise the interfacing is still the same:

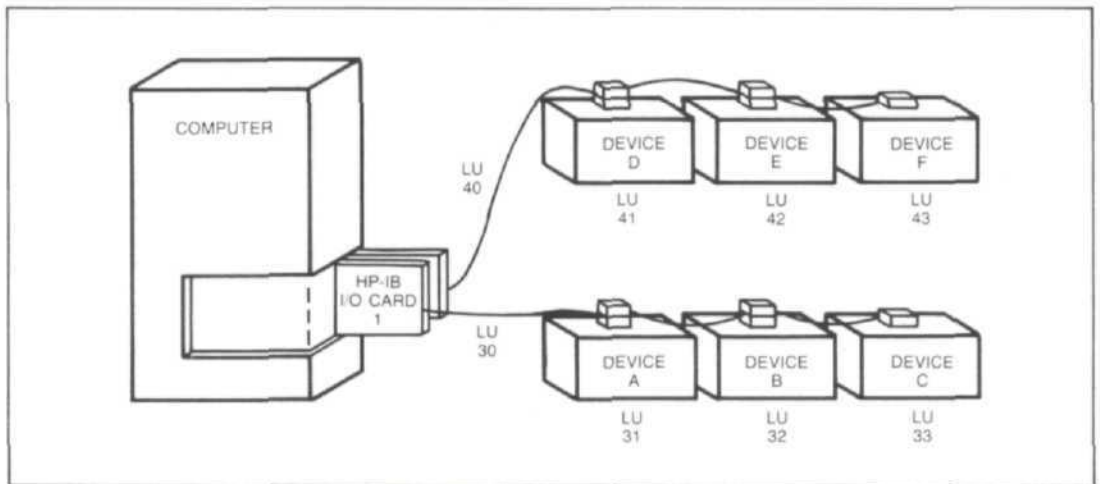

LU allocation to HP-IB devices

Other typical minicomputer LU allocations:

- |                                  |  |
|----------------------------------|--|
| LU 0 — Bit bucket (scratch file) | LU 4,5 — Left and right terminal data cartridges |
| LU 1 — System console            | LU 6 — Printer                                   |
| LU 2 — System disk               | LU 7 — Reserved for local printer                |
| LU 3 — Auxiliary disk            | LU 8 — Mag tape unit                             |

Interface addressing techniques (continued)



## UNIVERSAL COMMANDS

The five<sup>1</sup> multiline commands are:

Multiline Command <sup>2</sup>	Mnemonic	Decimal Code	Octal Code	ASCII/ISO <sup>3</sup> Character
Device Clear	DCL	20	24	DC4
Local Lockout	LLO	17	21	DC1
Serial Poll Enable	SPE	24	30	CAN
Serial Poll Disable	SPD	25	31	EM
Parallel Poll Unconfigure	PPU	21	25	NAK

### Multiline Universal Commands

<sup>1</sup>Untalk and unlisten are classified as addresses.

<sup>2</sup>The inclusion of these commands in the instrument is optional.

<sup>3</sup>Refer to Appendix B, page 94.

### Untalk Command UNT

The untalk command unaddresses the current talker. Sending an unused talk address would accomplish the same thing. This command is provided for convenience since addressing one talker automatically unaddresses others.

### Unlisten Command UNL

The unlisten command unaddresses all current listeners on the bus. Single listeners cannot be unaddressed without unaddressing all listeners. It is necessary that this command be used to guarantee that only desired listeners are addressed.

### Device Clear Command DCL

The universal device clear command causes all recognizing devices to return to a pre-defined device-dependent state. Recognizing devices respond whether they are addressed or in remote only. Device manuals define the reset state for each device that recognizes the command.

### Local Lockout Command LLO

The local lockout command disables a particular front-panel or rear-panel local-reset or return-to-local control (push button) on devices that recognize the command. Recognizing devices accept the command whether they are addressed or in remote only. REN must be set false to re-enable the pushbutton, this also replaces all devices under local control.

## ATN

### Serial Poll Enable Command SPE

The serial poll enable command establishes serial poll mode for all responding talker devices on the bus. When they are addressed to talk, each responding device will return a single eight-bit byte of status from each device. Devices which recognize this command must have Talker interface capabilities to allow the device to output the status-byte.

### Serial Poll Disable Command SPD

The serial poll disable command terminates serial poll mode for all responding devices, returning the devices to their normal talker state where they output device-dependent data rather than status information.

### Parallel Poll Unconfigure Command PPU

The parallel poll unconfigure command resets all parallel poll devices to the idle state (unable to respond to a parallel poll).

The four Uniline Commands are:

Uniline Command	Interface Management Line
Interface Clear	IFC
Remote Enable	REN
Attention	ATN
Identify (IDY)	EOI + ATN

Uniline Universal Commands  
(IFC and REN to be described later)

### ADDRESSED COMMANDS:

The following table lists the addressed command group.\*

Addressed Command	Mnemonic	Octal Code
Group Execute Trigger	GET	10
Selected Device Clear	SDC	04
Go to Local	GTL	01
Parallel Poll Configure	PPC	05
Take Control	TCT	11

Addressed Commands

\*A device may or may not be designed to respond to any particular addressed command.

### Group Execute Trigger Command GET

The group execute trigger command causes all devices which have the GET capability and are currently addressed to listen to initiate a preprogrammed action (e.g., trigger, take a sweep, etc.). Some devices may also recognize a device-dependent data character or string for this function (equivalent but requires entry into DATA MODE). The GET command provides a means of triggering devices simultaneously.

### Selected Device Clear Command SDC

The *selected* device clear command resets device currently addressed to listen to a device-dependent state (e.g. turn-on state, open all relays, etc.). Device manuals define the reset state for each device that recognizes the command. Same as DCL.

### Go to Local Command GTL

The go to local command causes the device currently addressed to listen to return to local panel control (exit the REMOTE state). The device will return to remote when it is addressed to listen again.

### Parallel Poll Configure Command PPC

The parallel poll configure command causes the addressed listener to be configured according to the parallel poll enable secondary command which will follow.

## SECONDARY COMMANDS

These consist of lower case ASCII alpha characters used for extended talk and listen addresses and secondary parallel-poll commands.

Secondary Command	Mnemonic	Octal Code	Decimal Code	ASCII/ISO Character
Parallel Poll Enable	PPE	140-157	96-111	i-o
Parallel Poll Disable	PPD	160	112	p

### Secondary Commands

#### Parallel Poll Enable Command PPE

The parallel poll enable secondary command configures the devices which have received the PPC command to respond to a parallel poll on a particular HP-IB DIO line with a particular level. Some devices may implement a local form of this message (e.g. jumpers).

#### Parallel Poll Disable Command PPD

The parallel poll disable command disables the devices which have received the PPC command from responding to the parallel poll.

## IFC, REN

### DATA MODE

In the DATA MODE (ATN false) device dependent data (e.g. programming data, measurement data, or status data) is sent from the active talker to the active listeners on the interface. The encoding and formatting of this data is an OPERATIONAL area issue of the interface and as such was beyond the range of the interface standards. A discussion of Hewlett Packard's experiences in DATA MODE code and format convention follows later in "Designed For Systems Aspects."

IFC (Interface Clear) — the IFC line is used only by the SYSTEM CONTROLLER to halt current operations (communications) on the bus (i.e. un-address all talkers and listeners and disable Serial Poll). All devices must monitor IFC at all times and respond within 100  $\mu$ sec (minimum pulse width for IFC).

REN (Remote Enable) — The REN line is used only by the SYSTEM CONTROLLER to enable devices to be subsequently placed in the remote programming mode. When true, all listeners capable of remote operation are placed in remote when addressed to listen. When false, all devices return to local operation. All devices capable of both remote and local operation must monitor REN at all times. Devices must respond to REN within 100  $\mu$ sec.

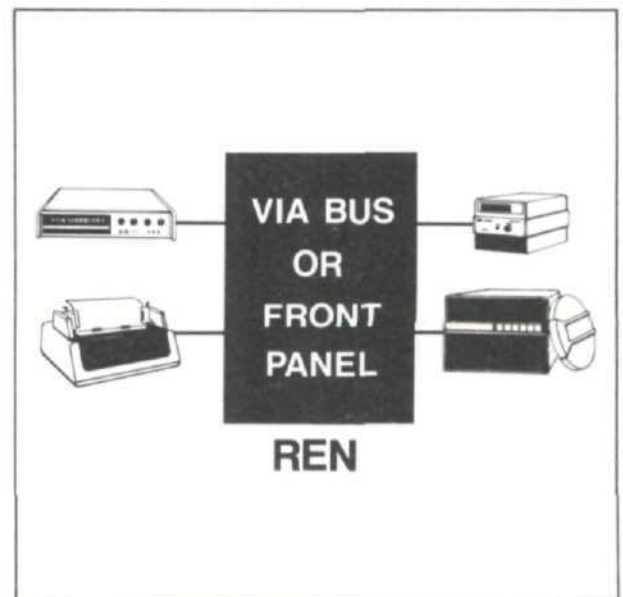
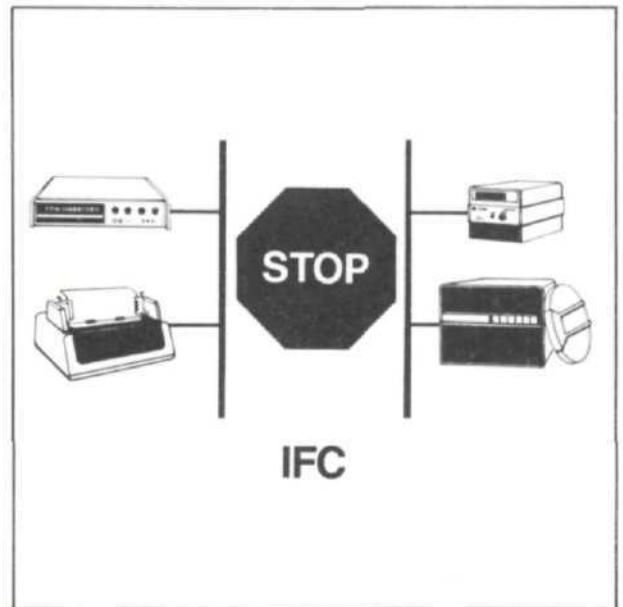

**SRQ (Service Request)** — The SRQ line is used by one or more devices to indicate the need for attention and can act as an interruption of the current sequence of events. Typically SRQ indicates data is ready to transmit and/or an error condition (e.g. syntax error, overload, trigger too fast, etc.) exists. The controller can mask the SRQ interrupt and must perform a POLL of devices to determine who requested service and why. SRQ is cleared by a SERIAL POLL only.



## POLLING

There are two possible polling procedures on the HP-IB:

1. SERIAL POLL
2. PARALLEL POLL

## SERIAL POLL

A SERIAL POLL is a sequence which enables the controller to learn if a device or group of devices requires service and/or determine multi bit status of devices on the interface.

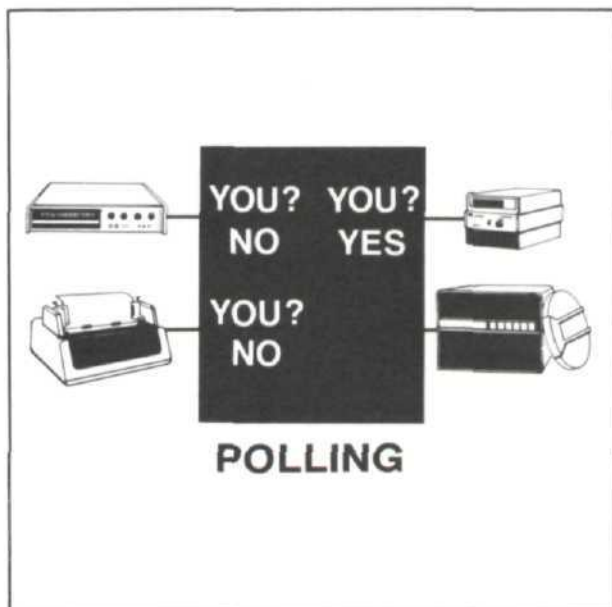

## EOI

Devices which can be SERIAL POLLED will return a STATUS BYTE (requires Talker subset) to the controller to indicate their status under program control. The controller sequentially polls each individual device on the interface (sends a SPE if IFC is false and sequentially addresses devices to talk) and evaluates each status byte in turn. Therefore, this procedure can be lengthy in larger systems, but does provide the nature of the request at the same time as the identity of a requestor.

You should (although it's not mandatory) poll every device to be sure you find every requestor and remember to send Serial Poll Disable (SPD) and Untalk (UNT) commands when you're done with the procedure although newer controllers now do this for you using high level commands.

### PARALLEL POLL

Parallel poll is a controller initiated operation to obtain information from the devices. When the controller initiates a parallel poll, each device returns a STATUS BIT via one of the DIO lines. Device DIO assignments are made by switches or jumpers or by the controller during the PPC (parallel poll configure) sequence. Devices respond either individually, each on a separate DIO line, or collectively on a single DIO line or any combination thereof. When responding collectively, the result is a logical AND or OR of the groups of status bits. Configured devices must respond to a PARALLEL POLL (the simultaneous assertion of ATN and EOI) within 200 nanoseconds. The controller can then read the results of the poll 2 microseconds later. Parallel poll is often used in the computer world to check the status of the action, i.e., which peripherals are ready for data, sending data or receiving data. By knowing this information dead times are reduced and the system bandwidth is used more efficiently.

### EOI (End or Identify)

When ATN is true the EOI line is used by a controller to execute a parallel poll (already described). When ATN is false, the EOI line is used by an active talker to indicate the last byte of a data message (e.g. burst amplitude and phase measurements, programming strings, etc.)

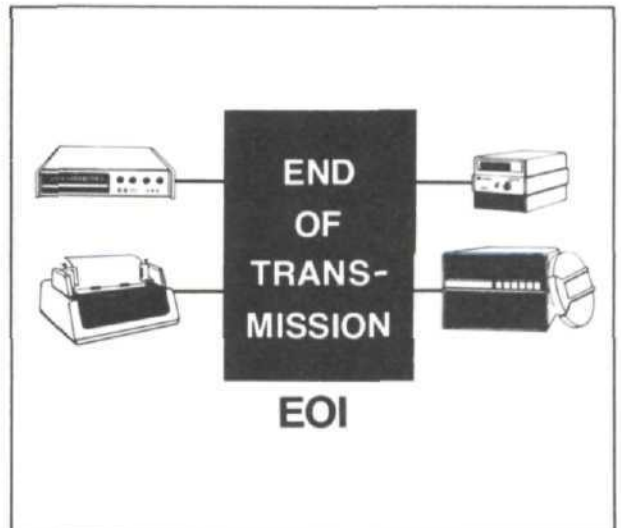

## Electrical aspects

### General.

The relation between logic and voltage levels is:

<u>Logic Level</u>	<u>Voltage Level</u>
0 (False)	$\geq +2.0V$ (High)
1 (True)	$\leq +0.8V$ (Low)

### Driver Types

<u>Open Collector Only</u>	<u>Open Collector or *Tristate</u>
SRQ, NRFD, NDAC	ATN, IFC, REN, EOI, DAV
DIO1-8 (Parallel Poll devices)	DIO1-8 (non-Parallel Poll devices)

\*Tristate useful to reach data rates above 250,000 bytes/sec. Tristate is disabled during parallel poll.

### Driver Specifications

$V_{OL} < +0.5V$ @ 48 ma continuous sink (tristate or open collector)
$V_{OH} \geq 2.4V$ @ 5.2 ma source (tristate)
see DC Load Line Graph (open collector)

### Receiver Specifications

<u>Preferred (Schmitt-type)</u>	<u>Allowed (non-Schmitt-type)</u>
$V_{IL} = V_{tneg} \leq +0.8V$	$V_{IL} \leq +0.8V$
$V_{IH} = V_{tpos} \geq +2.0V$	$V_{IH} \geq +2.0V$
Hysteresis: $V_{tpos} - V_{tneg} \geq +0.4V$	

## DEVICE LOAD REQUIREMENTS

The DC and small signal AC load requirements are summarized here and clarified with a typical circuit design:

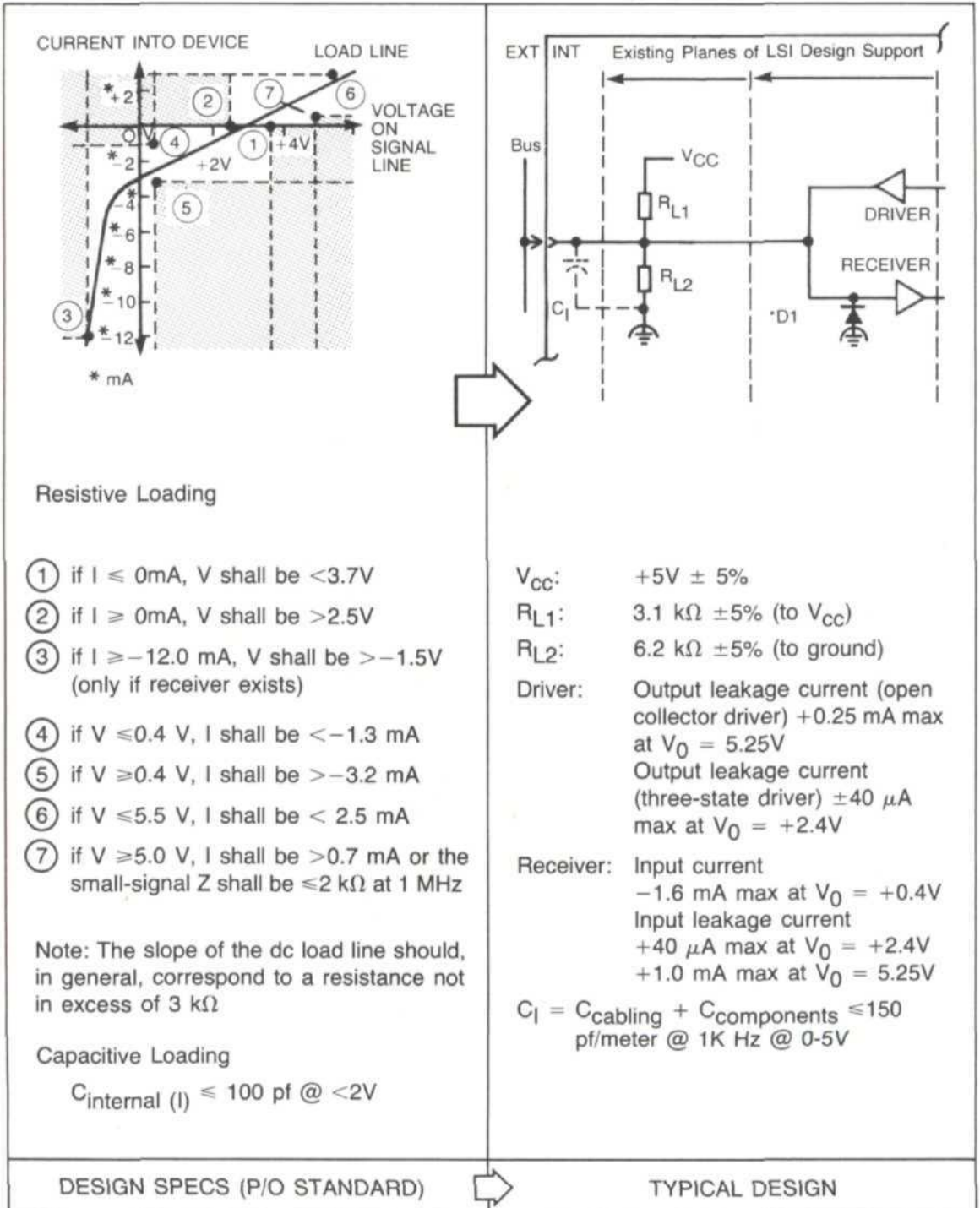

CONVERTING ELECTRICAL SPECIFICATIONS TO HP-IB TRANSCEIVER CIRCUIT

28

OVERVIEW



## Mechanical aspects

The connector, mounting, and cabling specifications of the interface define a flexible cabling system for interconnecting HP-IB devices. Devices can be interconnected in STAR, LINEAR, or combinational arrangements. An overall cabling restriction of 20 meters total or 2 meters per device, the lesser of the two, applies. For example, the maximum cable length is 4 meters if only 2 devices are involved. The length between adjacent devices is not critical as long as the overall restriction is met.

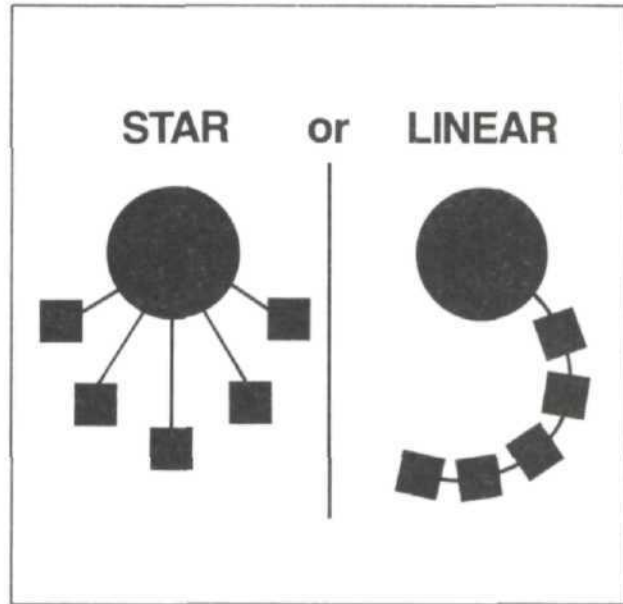

Cabling arrangements

**Connector.** The IEEE 488/ANSI MC1.1 connector is a 24-pin ribbon type connector with contacts assigned as shown here. A few key electrical and mechanical specifications:

Voltage rating: 200 Vdc

Current rating: 5A

Endurance:  $\geq 1000$   
insertions

Temperature and Humidity:

MIL STD 202E

Suggested connectors:

Microribbon

(Amphenol or Cinch Series 57) or

Champ (AMP)

The IEC 625-1 connector is a 25-pin type connector (MIL-C-24308) with contacts assigned as shown here. A few key electrical and mechanical specifications:

Voltage rating: 60 Vdc

Current rating: 5A

Endurance:  $> 1000$   
insertions

Temperature and Humidity: IEC Publication 68 for climatic category 25/070/21.

**Mounting.** (IEEE/ANSI Connector)

Metric threads (ISO M3.9  $\times$  0.6 type) are specified. Metric fasteners are typically black. Some existing cables use English threads (6-32UNK). They are silver. DO NOT ATTEMPT TO MATE SILVER AND BLACK FASTENERS, as damage to hardware may result.

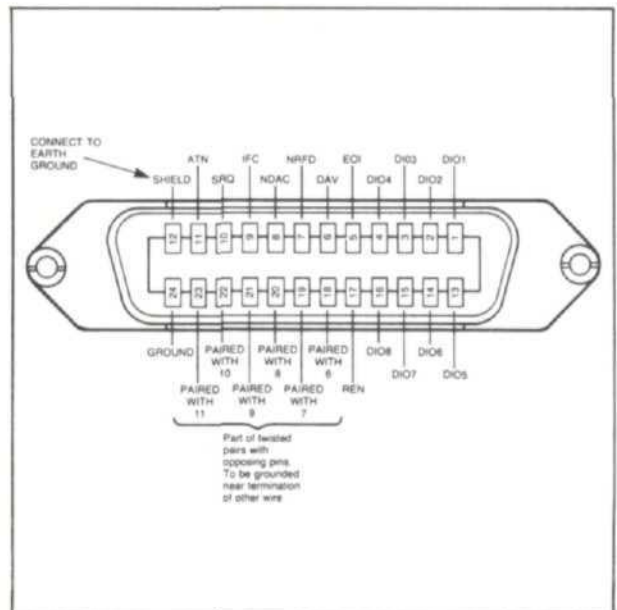

IEEE/ANSI connector



IEC connector

## Designer guidelines from the IEEE-488

### SPEED

With one device for every 2 meters of cable, the data rate can be 250 kbytes/second over distances of 20 meters using open collector drivers. Tristate drivers can increase the data rate to 500 Kbytes/second.

**Question:** How do I achieve data rates faster than 500 Kbytes/second and up to 1 Mbyte/second?

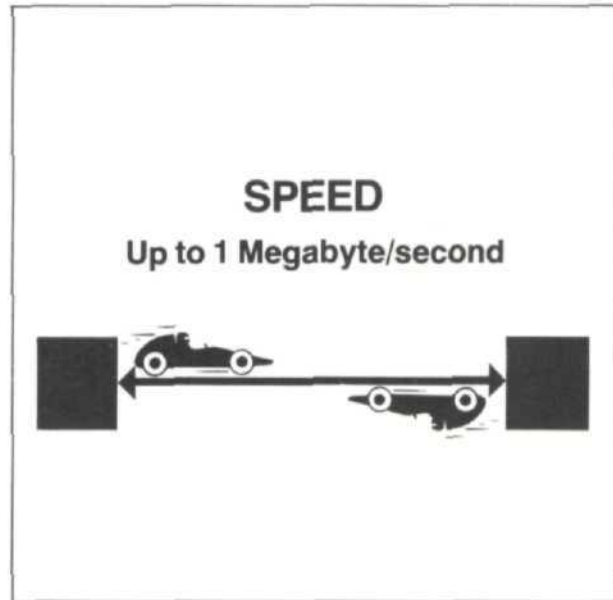

**Answer:** First — Be sure all high rate devices use Tristate drivers (Interface capability I.D. E2) and that every device is turned on.

Second — Minimize cable length! Do *not* exceed 15 meters total cable length and ensure one device for every meter of cable.

Third — Limit the capacitance of each device on each line to at most 50pf (@ <2V) (except REN and IFC).

Fourth — All high rate Talkers should use a minimum multiline message settling time ( $T_1$  in the IEEE-488 Standard) of 350 ns.

Also — Buffered data byte storage in a device is advantageous. Devices with a  $T_1$  value less than 500 ns, an internal device capacitance of  $\geq 50$ pf, or multiple resistive loads should be marked accordingly (typically done on CONTROLLERS).

See also IEEE standard 488-1978 section 5.2.

### DEVICES POWERED OFF AND ON

Systems will operate normally with up to 1/3 of the devices powered off and even more as long as  $V_{OH}$  on each line on each device still exceeds the +2.5V specification. Turning on a device while a system is running may cause faulty operation.

## Summary of 1978 revisions to IEEE 488/ANSI MC1.1

The November 1978 revision to the IEEE 488/ANSI MC1.1 standard was mostly ( $\approx 90\%$ ) for clarification. Heavy use in the seventies had brought out several areas of possible misinterpretation and several useful new guidelines/recommendations.

### IEEE STD. 488-1978

- EDITORIAL CLARIFICATIONS
- INTERFACE FUNCTION COMBINATIONS
- END MESSAGE CLARIFICATION
- SYNCHRONOUS TAKE CONTROL
- TRANSCEIVER SPECS
- HIGHER SPEEDS
- OPERATIONAL SEQUENCE
- CAPABILITY ID

Summary of 1978 revision

- Additional restrictions on allowable combinations of interface functions were added.
- Clarification of exactly how the END message is treated in source and acceptor interface functions was added.
- A minor revision to the CONTROLLER function (delay) was made to ensure against the possible simultaneous assertion of DAV and ATN which could be interpreted by idle devices as COMMAND MODE information, initiating a handshake sequence.
- The electrical specification for  $V_{OL}$ , the minimum low-state output voltage for bus drivers was raised to +0.5V to accommodate modern low-power Schottky drivers.
- More information was provided on how to maximize the Data Transfer rate over the interface.
- Warnings with guidelines about conducting and/or exiting particular operational sequences were added. For example, remembering to send Serial Poll Disable (SPD) followed by Universal Untalk (UNT) to exit each serial poll sequence.
- A non-mandatory recommendation to mark the device's interface function codes and electrical driver type near the device's connector to aid the system designer and user.

## CAPABILITY I.D.(NOT MANDATORY)

The ANSI/IEEE-488 recommends that all devices be marked near its connector with the interface function codes it supports.

For example, a device with the basic talker function, the ability to send status bytes, the basic listener function, a listen only mode switch, service request capability, remote local capability without local lockout, manual configuration of the parallel poll capability, complete device clear capability, no capability for device trigger, and no controller capability would be identified with these codes.

E1 identifies open collector drivers and E2 would identify tristate drivers in the data mode.

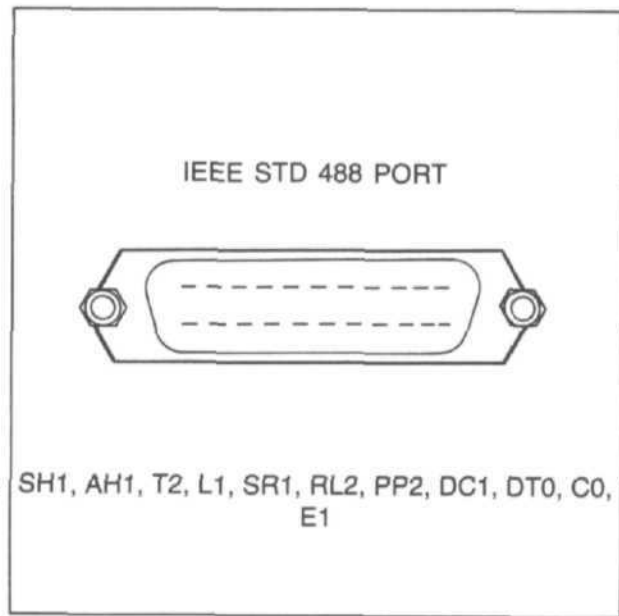

Capability I.D. codes

Appendix A, page 90, gives an in-depth description of these capability codes along with a list of capability codes for Hewlett-Packard products.

## “Designed for systems” aspects

As we have already seen, Hewlett Packard’s experience designing instrumentation and computation products for the system designer results in many “Designed for Systems” benefits to the final system designer, programmer, and user. Although these features are not required by the IEEE 488 or ANSI MC1.1 or IEC 625-1 Part 1, they are part of HP-IB. Let’s review some of the “Designed for Systems” features of HP-IB components . . .

## Operational aspects

### EXPERIENCE IN THE DATA MODE

In the DATA MODE (ATN false) device dependent data (e.g. programming data, measurement data, or status data) is sent from the active talker to the active listeners on the interface. The encoding and formatting of this data is an OPERATIONAL aspect of the interface and as such was beyond the range of the interface standard. Experience in this area, however, has led to some agreed upon, generalized code and format structures for the DATA MODE. In general, the format for programming data strings used in typical Hewlett-Packard HP-IB products consist of sets of alphanumeric character sequences. One or more alpha characters identify a parameter and the numeric field identifies the parameter selection or value. Specific code assignments, however, are unique to each device. For example, the following message programs a voltmeter to measure a dc voltage on the 10-volt range upon receipt of an internal trigger, and then output the measured quantity.

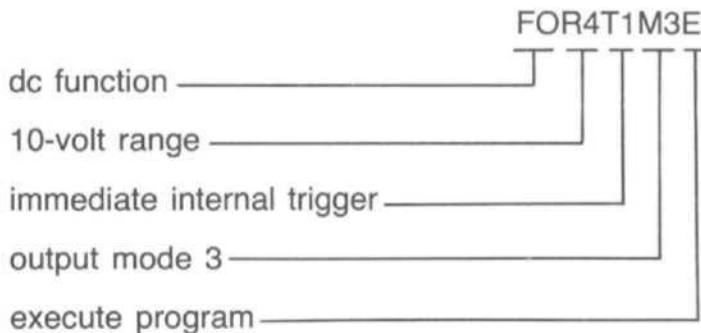

The voltmeter's response to the command might be:

`OLDC + 12002E - 03Cr Lf (EOI)`

Here, the OLDC provides summary status data indicating that the measurement is a dc voltage but the value, in this case +12.002 volts expressed in exponential notation, is beyond the normal 10-volt range specified and is therefore flagged as an overload condition. This message can be divided into three fields: header (alpha only), numeric value representing the measured

quantity, and separator or ending to the message (the carriage return/line feed concurrent with the EOI line on the bus). The overall structure of the format is defined but individual product implementations select the particular message elements appropriate for that product. For example; the instructions may be chosen to represent action (i.e. action oriented) or to represent a particular card (i.e. card oriented).

Even though guidelines for preferred syntax and format conventions were not part of the original IEEE-488 document, work continued in this area in order to increase the useability of different vendors' equipment. This work resulted in "IEEE-728-1982, Recommended Practice for Code and Format Conventions for IEEE Standard 488." This document contains a series of recommendations (guidelines) rather than being a standard (in absolute terms) and is a valuable companion document to those designing products incorporating IEEE-488. Also, there is an IEC document, IEC 625-2, which deals with the same subject matter but whose content is not identical to IEEE-728.

The standardization effort to date can be graphically depicted:

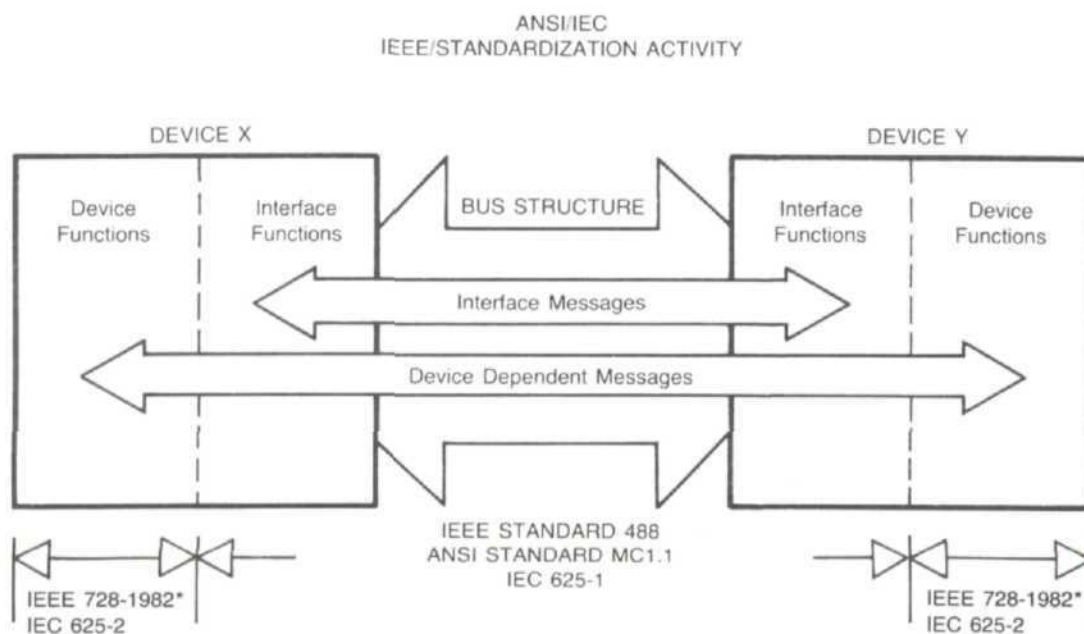

\*IEEE 728-1982 Recommended Practice for Code and Format Conventions



HP's HP-IB Interconnect cables offer improved shielding for reduced radiated emissions from cabling in systems environments. Here's some helpful info:

### INTERCONNECTION RULES

An HP-IB system may be connected together in any configuration (star or linear or combination) as long as the following rules are followed:

1. The total number of devices is less than or equal to 15.
2. The total length of all the cables used is less than or equal to 2 meters times the number of devices connected together up to an absolute maximum of 20 meters.

The length between the adjacent devices is not critical as long as the total accumulated cable length is less than or equal to the maximum allowed. Star, linear, and combination configurations are allowed.

### METRIC HARDWARE

The mounting hardware uses metric threads (ISO M3.9x0.6). They are colored black. On some early (pre 1975) versions of the cables, the hardware used English Threads (6-32 UNC). These were silver color. **DO NOT ATTEMPT TO MATE SILVER AND BLACK FASTENERS**, as damage to the hardware may result. A metric conversion kit which will convert one cable and one or two instruments to metric hardware is available by ordering HP Part No. 5060-0138.

### SPECIFICATIONS

MODEL NO.	LENGTH
10833A	1 m (3.28 ft)
10833B	2 m (6.56 ft)
10833C	4 m (13.12 ft)
10833D	0.5 m (1.64 ft)

It is recommended that no more than three of the connector blocks be stacked one on top of another as the resultant cantilevered structure can exert excessive force on the mounting panels when the stack of connector blocks becomes too long. The lock screws are designed to be tightened with the fingers only. Do not use a screwdriver. The screwdriver slots in the lock screws are provided for removal purposes only.

The new cables are completely compatible with, and can be used in combination with, the older style cables. However, this will affect the continuity and effectiveness of the shielding.

### MATING CONNECTOR AND MOUNTING HARDWARE

ITEM/DESCRIPTION	HP PART NUMBER
Connector: 24-Pin Receptacle	1251-3283 (Amphenol 57-20240-2)
Mounting Stud, Long: For outside panel mounting (two required)	0380-0643
Lock Washer*: #8, split, 0.047" thick, for use with 0360-0643 (two required)	2190-0017
Mounting Stud, Short: For inside panel (.063" thick) mounting (two required)	0380-0644
Lock Washer: #10, split, for use with 0360-0644 (two required)	2190-0034

\*NOTE: Use of specific lock washer is required to maintain spacing.



The HP 10834A adapter was designed to help in those cases where limited rear panel space and other design considerations have resulted in difficult cabling situations. The adapter extends the first cable approximately 2.3cm away from the rear panel to provide clearance for other connectors, switches and cables that may be in close proximity to the HP-IB connector.

### ADAPTER DIMENSIONS

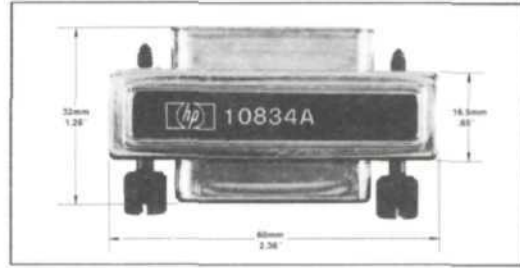

### CONNECTOR DIAGRAM

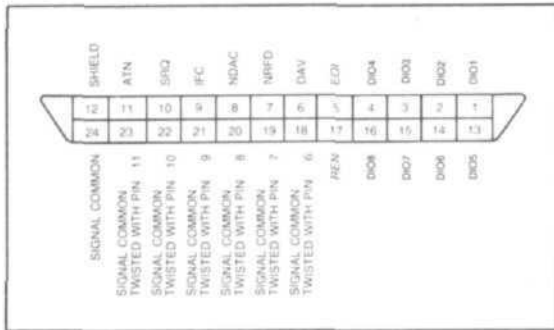

### CONNECTOR DIMENSIONS

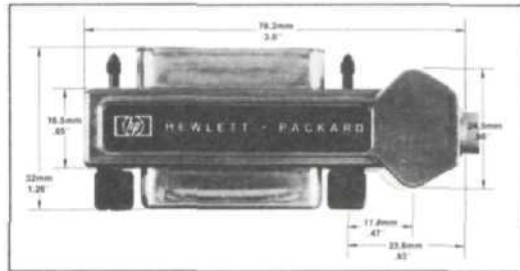

## **OTHER SYSTEMS-RELATED CABLING**

You may find a single source for all your system cabling needs helpful. With that in mind:

- Direct Phone Ordering for U.S. Customers (800) 528-8787  
California: (408) 738-4133
- Shipment within 24 hours; guaranteed
- Easy to use reference guide in our new Computer Supplies Catalog.

Here is the current list:

Type of Cable	CSO Ordering Number	Description	HP Equivalent
HP-IB Cables	31389A	1 meter	10631A
	31398B	2 meter	10631B
	31389C	4 meter	10631C
HP-IB Cable (Low RFI)	10833A	1 meter	10833A
	10833B	2 meter	10833B
	10833C	4 meter	10833C
	10833D	.5 meter	10833D
HP-IB Adaptor	10834A	HP-IB Connector Adaptor/Extender — 2.3 cm	10834A
*RS-232C Cables	262X Terminals:		
	13222-60003	RS-232C Data Cable — 2 meters	13222C
	13222-60002	European Modem Cable — 5 meters	13222M
	13222-60001	U.S. Modem Cable — 5 meters	13222N
	13222-60007	262X to HP 300 — 5 meters	13222W
	264X Terminals:		
	02640-60058	HF 1000 CPU to Terminal — 15 meters	13232B
	5061-2409	European Modem Cable — 4.5 meters	13232M or 13232A
	02640-60049	264X to RS-232C — 1.5 meters	13232C
	02640-60131	U.S. Modem Cable — 4.5 meters	13232N
	Multipoint:		
	02640-60132	Multipoint Cable for first terminal — 4.5 meters	13232P
	02640-60133	Multipoint Cable for 2nd to 32nd terminal — 4.5 meters	13232Q
	02640-60134	Multipoint extension Cable — 30 meters	13232R
	02640-60151	Multipoint power protect — 9 meters	13232T
	5061-2410	264X to HP 300 — 6 meters	13232W
	Modem Cables:		
	30062-60020	7.6 meters	30062B
30062-60021	15 meters connects HP 3000 to 103/202S modems		
Modem Eliminators:			
5061-2403	Modem eliminator, cable not shielded — 1.5 meters	13232U	
31390A	Modem eliminator, cable shielded — 5 meters	None	
Extender Cables:			
31391 A, B, C & 30062-60012	Standard M/F RS-232C connectors with 25 pins wired end-to-end: A — 5 meters B — 10 meters C — 15 meters 30062-60012 — 30 meters	30062C	
30062-60018	Hardwire extension cable, 3 wires — 30 meters	30062D	

\*For a more thorough list of cables from Hewlett-Packard refer to HP P/N 5953-2450, "Computer Supplies Catalog," Autumn-Winter 1982. Order via above phone numbers, through local Hewlett-Packard sales office or write Hewlett-Packard, P.O. Box 60008, Sunnyvale, CA 94088.

## **Additional helpful HP-IB information**

### RECENT DESIGN AND SERVICE AIDS

Among the most useful design aids for designing IEEE 488/ANSI MC1.1/IEC 625-1 capabilities into a product are:

- LSI chips for implementing CONTROLLER, TALKER, and LISTENER interface function combination
- A flexible BUS ANALYZER
- Timing Analysis for the bus (plus State Analysis)
- Serial Analysis for Data Communications and Interfacing applications in a Distributed Measurement Systems Environment.

LSI chip versions of the CONTROLLER, TALKER, and LISTENER interface functions are available (see next page) to facilitate your design process. These chips can implement selected functions or combinations. More recent chips include CONTROLLER capabilities (may be a separate chip). In all cases they typically replace between 40 to 60 MSI or SSI parts per function (Controller, Talker, Listener) on partially dedicated I/O boards. That's 120 to 180 parts for a full hardware version!

To perform the same functions via a typical MPU/ROM implementation might require 500 bytes per function. That's a full 1.5K bytes and a dedicated processor (e.g. an OUTGUARD processor in a DVM) as well. Here's a brief summary of LSI chips to date:

#### Comparison Of LSI Interface Chips

MANUFACTURER	PART NUMBER	SUPPLY VOLTAGE (V)	CLOCK RATE (MHz)	POWER DISSIPATION (mW)		DATA TRANSFER RATE (BYTES/SEC)	SECOND SOURCE	FUNCTION	COMMENTS
FAIRCHILD	96LS488	5	10	*125*	LOW POWER SCHOTTKY	1M	NONE ANNOUNCED	TALKER/LISTENER	LPS DRIVERS BUILT IN FOR ADDED NOISE IMMUNITY
***INTEL	8291	5	8	500	NMOS	448K	NONE ANNOUNCED NEC	TALKER/LISTENER CONTROLLER	8 MHz MPU REQUIRED
	8292	5	6	625					
PHILIPS/SIGNETICS (U.S.)	HEF4738V	4.5 TO 12.5	2	**1	CMOS	200K	NONE ANNOUNCED	TALKER/LISTENER	MAY REQUIRE EXTERNAL MULTIPLEXERS, LEVEL SHIFTERS, DECODERS, DRIVERS
****TEXAS INSTRUMENTS	TMS9914A	5	5	750	NMOS	250K	NONE ANNOUNCED	TALKER/LISTENER CONTROLLER	ALL-IN-ONE DATA BYTE BUFFER SAFEGUARDS BUILT-IN

\*With any three bus outputs in a low state. (Typical value 300 mW).

\*\*When in a quiescent state at 10V.

\*\*\*No support chips as yet (8293 Bus support chip coming).

\*\*\*\*SN 75160 data bus transceiver and SN 75162 management bus transceiver also available.

For more information on these products contact the following manufacturers:

Fairchild Semiconductor  
464 Ellis St.  
Mt. View, CA 94042  
(415) 962-5011

Signetics Corp.  
Box 409  
Sunnyvale, CA 94086  
(408) 746-1676

Intel Corp.  
3065 Bowers Av.  
Santa Clara, CA 95051  
(408) 987-8080

Texas Instruments Inc.  
Box 1443, MS 6404  
Houston, TX 77001  
(713) 776-6511

Motorola Integrated Circuits Div.  
3501 Ed Bluestein Blvd.  
Austin, TX 78721  
(512) 928-6800

A flexible BUS ANALYZER is a very useful product for aiding the HP-IB hardware/software designer in development and diagnosing HP-IB hardware/software problems. Most BUS ANALYZERS operate with complete TALKER, LISTENER, CONTROLLER, and SYSTEM CONTROLLER Interface Function capabilities which are



Hewlett-Packard's Bus Analyzer . . . the 59401A

mutually independent and exhibit near-ideal (typically <750 ns with <200 ns possible) accept times ( $T_3$  in the IEEE-488 standard) for almost complete transparent bus monitor and test applications. Other applications include device and controller simulation and interface function verification.

TIMING ANALYSIS is sometimes useful when optimizing/characterizing HP-IB product or system performance; or when diagnosing noise, timing, or software synchronization related faults in a product or system. Most TIMING ANALYZERS provide at least the 16 channels required to monitor HP-IB signal lines and more than enough bandwidth. 8 bits of TIMING and 16 bits of STATE analysis at up to 20 MHz can be provided as with Hewlett-Packard's Model 1615A Logic Analyzer.

SERIAL DATA ANALYSIS (MONITORING or DTE/DCE Simulation) is sometimes useful when you expect your HP-IB Measurement System to be or evolve into a Measurement Node in a larger distributed system environment via a serial network link or HP-IB extension technique. The network link would tie the local measurement-intensive system to a centralized computational-intensive system via a local networking scheme (Public Data Networks). A serial network link would also be of use for *emulating a terminal* via an ASYNCHRONOUS format or for Remote Job Entry (RJE) type applications for accessing the shared resources of the larger host (IBM 360/370) computer in the network via a SYNCHRONOUS format (Bisync, HDLC, SDLC, etc.). Other applications would also include any use of specialized RS-232-C instrument interfacing for adding older or non-IEEE-488/ANSI MC1.1 instruments and peripherals, or perhaps if a Factory Data Link (FDL) terminal will be utilized in your instrumented system to capture data throughout your automated production process.

A SERIAL DATA ANALYZER is an invaluable tool for developing and maintaining these links. The Hewlett-Packard Model 1640B is a general purpose SERIAL DATA ANALYZER for monitoring or simulating serial communications between Data Terminal Equipment (DTE) and Data Communications Equipment (DCE) in such a distributed systems environment whenever a serial interface is required.

## OPTIMIZING HP-IB SYSTEM PERFORMANCE AND OVERCOMING CONSTRAINTS

There are three areas of HP-IB performance that are most often asked about. These are:

- Surpassing the 15 device-per-bus constraint (Number of Devices per Bus).
- Surpassing the 20 meter total cable length constraint (Total Accumulated Cable length).
- Maximizing the data transfer rate of the interface. (Maximum Transfer Rate).

Each of these topics is discussed separately.

### NUMBER OF DEVICES PER BUS

15 devices fills about three 56-inch bays with equipment and constitutes a fairly elaborate system. In most cases, this is not a major restriction. If you should have a need for more devices you can use an additional interface (another card in your desktop or minicomputer). If you run out of slots, some computers have I/O EXPANDERS for increasing the number of slots available.

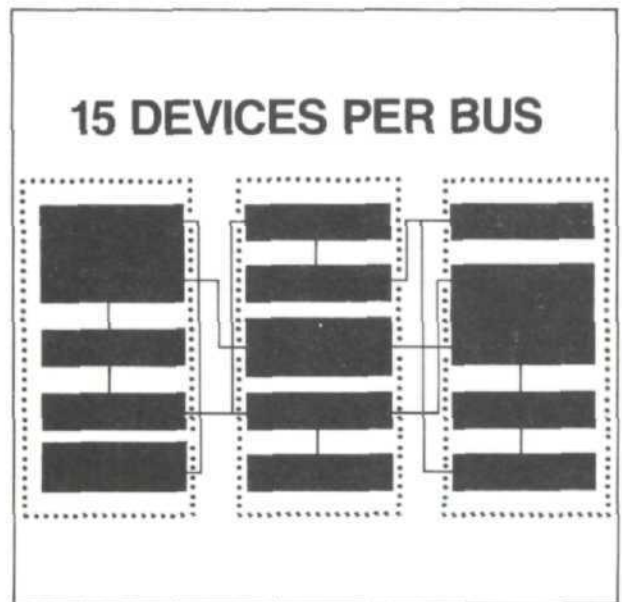

About 3 bays

For HP computers:

HP COMPUTER	# COMPUTER I/O SLOTS	HP INTERFACE CARD	HP I/O EXPANDER	# EXPANDER I/O SLOTS
Series 80 { 85 86 87	4	82937A	None	NA
9825	3	98034B Opt. 25	9878A	6
Series 200 { 9826 9836	4	Built in	9888A	16 (8 for I/O)
9845	4	98034B Opt. 445	9878A	6
1000 M, E, F	*16 maximum	59310B	12979B	16
1000 L	*13 maximum	12009A	None	NA

\*very dependent on system peripheral requirements. Typical maximums given.

## TOTAL ACCUMULATED CABLE LENGTH

For data rates below 500K bytes/second you are constrained to 20 meters total or 2 meters per device, whichever is less. There are 2 techniques for surpassing this limitation

INTRA-FACILITY HP-IB EXTENSION and INTER-FACILITY HP-IB EXTENSION. These are described on p. 44.

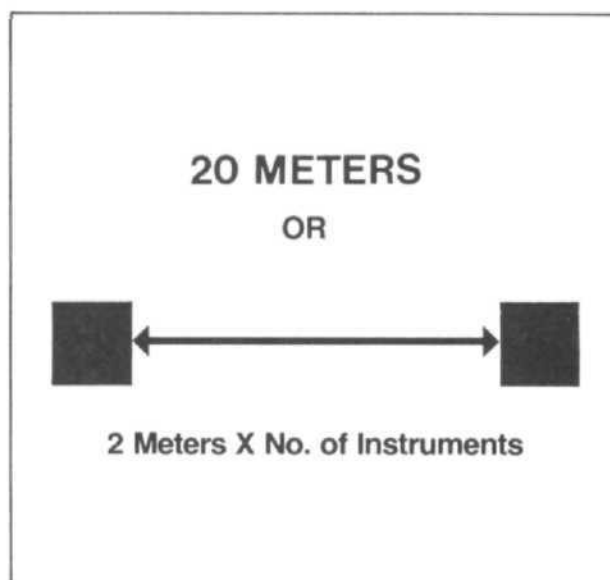

The cable length restriction

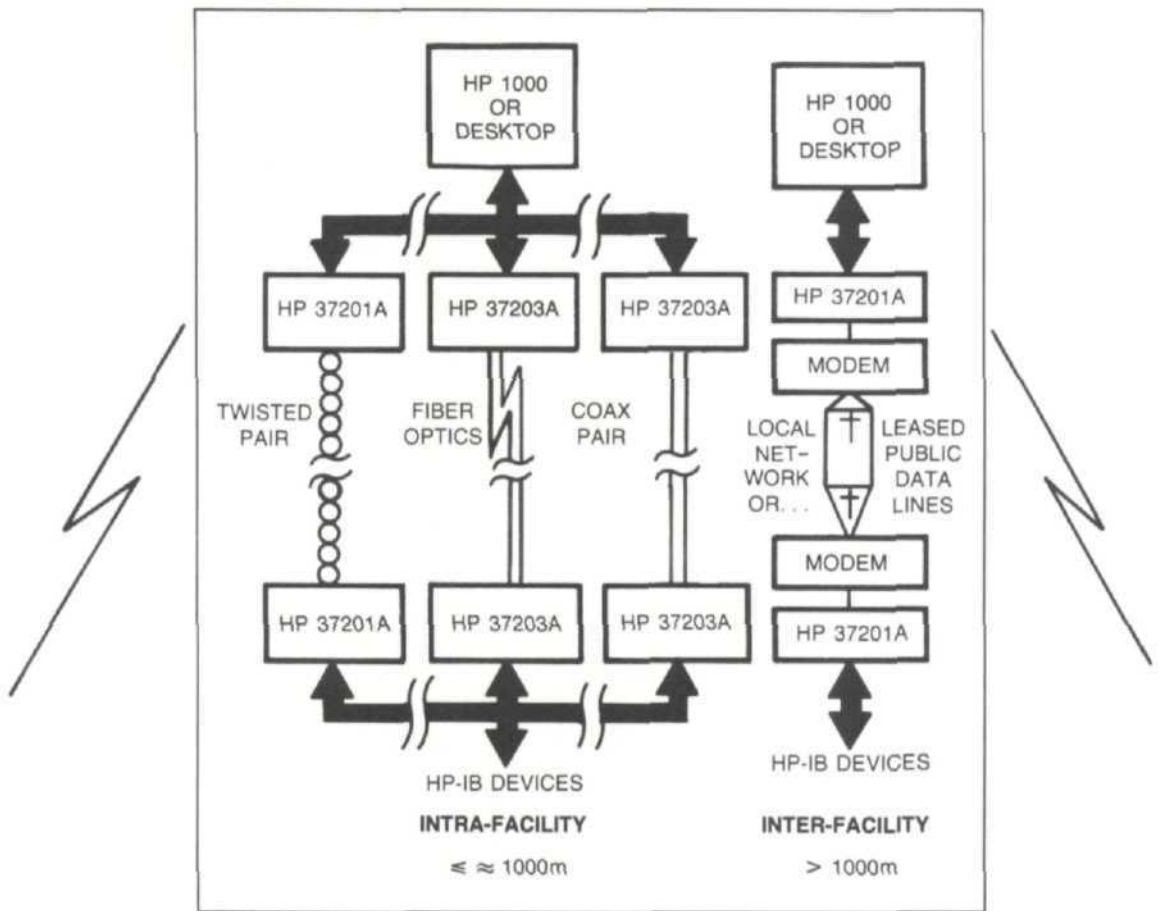

### Extending the HP-IB

Intra-Facility HP-IB Extension Can:	Inter-Facility HP-IB Extension Can:
<ul style="list-style-type: none"> <li>a. Extend HP-IB capabilities up to 1000 meters away.</li> <li>b. Save you money on cabling (can be up to \$10/ft!).</li> <li>c. Avoid the cost of additional computers.</li> <li>d. Protect your computer from harsh environments, extreme noise, or unwanted user access.</li> <li>e. Preserve HP-IB flexibility at the remote end of the extension.</li> <li>f. Be partially (37201A) or totally (37203A) transparent to the user.</li> </ul>	<ul style="list-style-type: none"> <li>a. Provide all of the benefits of Intra-Facility over unlimited distances with leveraged savings.</li> <li>b. Provide you with auto dial-up on one or more remote instrument clusters.</li> </ul>



## MAXIMUM TRANSFER RATE\*

You'll find for most instrumented systems your throughput limited by the instruments in the system. Precision measurements typically take time relative to the microsecond cycle times in desktop or minicomputers. High resolution (5½ - 6½ Digit) voltage measurements using integrating analog-to-digital techniques, precision low frequency counting, and narrow band spectrum analysis are all good examples of relatively slow real-time measurement processes. As instruments and peripherals get smarter and digital signal processing becomes easier and less expensive to implement in instruments, the short term (high-speed sampling, burst measurements, computer "dumps", block memory transfers, DMA's) HP-IB demands will increase. In these cases the system throughput can become bound by the transfer rate of the computer-interface combination. For HP's HP-IB Interface Cards and HP-IB Extender the theoretical transfer rate limitations are:

	HP CARD, COMPUTER OR EXTENDER	THEORETICAL MAXIMUM TRANSFER RATE (BYTES/SECOND)
Interface* Cards	82937A (85)	26.2K
	98034A (9825/45)	40K
	98624A (9826/36)	42K Input/60K Output
	59310B (1000 M, E, F)	768K
	12009A (1000 L)	1M
Bus Extension Devices	37201A HP-IB Extender	750**
	37203A HP-IB Extender	50K
	37203L HP-IB Extender for 1000 L Series	50K

\*Only limits transfers through the interface card itself, not over the entire cabling system.

\*\*Speed is determined by modem baud (bit) rate when used for INTER-FACILITY applications.

Interface transfer rate limitations

\*See also p. 32 "Designer guideline from the IEEE-488".

## Suggestions for improving software performance

If speed is critical in your application the following guidelines may prove useful:

### GENERAL (DEVICE DEPENDENT)

1. Familiarize yourself well with the operational aspects of the devices you're optimizing your routines for. Newer devices have fast-handshake and speed-advantageous features (e.g. buffering, program storage, hardware overlap, etc.) built-in.
2. Interrupt drive the process and down-load smart devices where possible. Some card-cage type instruments can perform many time consuming tasks through hardware features that otherwise might require significant software dedication and the associated overhead.
3. Avoid unnecessary unaddressing and readdressing steps where possible.
4. Use HP-IB Commands rather than device dependent messages where possible.
5. Suppress unneeded terminators.
6. Use system commands (already optimized) and binaries when they exist.
7. Get to know your HP-IB Specialist and Systems Engineers if you use HP equipment. They're highly trained specialists with timely answers to critical questions when you need them. Systems Engineers are also available on a consulting basis for a fee when you need dedicated consulting.

### LANGUAGE DEPENDENT

1. Develop the driver at the lowest-level possible and appropriate (e.g. assembly for repetitive fixed point processes, interface control for single interface commands, micro-code for FORTRAN, etc.). But develop larger programs and non speed-critical subprograms at higher levels as appropriate.
2. Use compiled languages when available, HP1000 FORTRAN. If you can link compiled modules in an interpretive environment you may find its speed advantageous.

## COMPUTER DEPENDENT (for HP Computers)

1. Reference formats (images) outside loops:

9825, 9826, 9836, 9845, 1000 M, E, F, L

2. Reference images inside loops:

85

3. Use multiple statements per line where possible:

85, 9825

4. Declare variable types for loop indices as follows:

85	REAL (DEFAULT)	9845	INTEGER
9825	N/A	SERIES 200	INTEGER

5. Turn the CRT OFF when unneeded. This may also apply to instruments where turning off a display, auto-zero, or other such feature can improve measurement throughput when not needed. Check the devices manual.

6. Use OUTPUT USING "K" to suppress leading and trailing spaces.

85

As an example with the 85: OUTPUT 724; "F1" will send out 19 spaces after F1 and before the CR/LF. OUTPUT 724 USING "K"; "F1" will send out no spaces.

7. I/O Device Path Names:

Series 200 (9816, 9826, 9836)

8. Follow the IEEE-488/ANSI "Designer Guidelines" presented earlier in the *Technical Overview*.

## Generally helpful information

Avoiding Typical HP-IB System Related Problems. Some suggestions to help things go smoothly:

1. Use an ALGORITHMIC DESIGN approach. It's simple, well structured, and has a history of success.
  - a. DEFINE your system needs well.
  - b. DESIGN the system solution.
  - c. EVALUATE the expected cost-effectiveness of your design.
  - d. BUILD the chosen solution.
  - e. USE the system once built.
2. Order system prestudy or device manuals and application notes as early as possible.

## HELPFUL INFORMATION, Cont'd.

3. An HP-IB BUS IMPLEMENTATION WORKSHEET is sometimes useful to visualize the ADDRESS and MESSAGE compatibility of the devices in your system. This technique can aid the system programmer in larger HP-IB systems. Once you've got documentation on the devices, the programmer can fill in the SEND and RECEIVE message capabilities of the devices vertically and compare horizontally. A sample WORKSHEET is on the facing page.
4. Develop hardware and software block diagrams or flowcharts for the tasks (measurement, test, control, data manipulation, presentation, etc.) you will need. You could do this while waiting for component or system delivery. Even better, do it as part of the DEFINING and DESIGNING steps of your system design.
5. Prepare the systems installation site adequately. Don't forget provisions for power distribution, interference protection, and such environmental considerations as temperature, humidity, static protection and physical clearances. Refer to the installation documents with your system and system components. A typical pre-installation planning checklist is on page 50.
6. Appoint a system manager who is responsible for maintenance and calibration schedules, operator training, configuration control and systems logs as well as for ordering such consumables as paper, ink, diskettes, and cartridges. Giving the user this responsibility will typically result in further job enrichment and self-fulfillment.
7. Don't try to automate *too* much or the *wrong* things. Some interconnect processes may best be done manually to avoid the error terms associated with system switching. Many processes just do not make sense to automate (Microwave connections, etc.).
8. Take care when estimating software requirements for the system. Expect a decreasing exponential learning curve on test programs. The time to learn a mini-computer based system and write the first test is typically 10 times that required for an equivalent desktop computer based system. The steady state ratio drops to about 2 times as long as fluency and mastery are achieved.
9. The STAR cabling configuration will minimize worst-case transmission path lengths but can lump large capacitance values at a single plane on the line. The LINEAR cabling configuration may produce longer electrical lengths but provides more control to distribute capacitive line loads for maximum error-free transmission.

		HP-IB BUS IMPLEMENTATION WORKSHEET											
MESSAGE		DEVICES											
INSTRUMENT IDENTIFICATION AND HP-IB ADDRESS	MODEL												
	LISTEN												
	TALK												
	5 BIT VALUE												
DATA													
TRIGGER													
CLEAR													
LOCAL													
REMOTE													
LOCAL LOCKOUT													
CLEAR LO & SET LOCKOUT													
REQUIRE SERVICE													
STATUS BYTE													
STATUS BIT													
PASS CONTROL													
ABORT													

S = SEND ONLY R = RECEIVE ONLY S & R = SEND AND RECEIVE N = NOT IMPLEMENTED

## DIRECTIONS

1. Refer to Device's documentation to determine which HP-IB messages they implement and their factory selected addresses. (Factory selected addresses beginning page 55 for most current HP HP-IB products.)
2. Fill in the WORKSHEET
3. Where S and R capabilities line up horizontally, you've got message compatability!
4. Check to be sure if a "hardware" version of a message is available between devices otherwise triggering, clearing [blinking], END

**INSTRUCTIONS.**

Check when each planning question has been completed. If a question does not pertain to your installation, mark the question N/A.

**Suitability of Site.**

- \_\_\_\_\_ 1. Is proper and adequate power available to site?
- \_\_\_\_\_ 2. If below ground level, is the water drainage system adequate?
- \_\_\_\_\_ 3. Has possible need for rigging been investigated?
- \_\_\_\_\_ 4. Are elevators adequate to support size and weight of equipment?
- \_\_\_\_\_ 5. Will stairways allow passage of equipment?
- \_\_\_\_\_ 6. Will flooring enroute in installation site support weight of equipment?
- \_\_\_\_\_ 7. Will all doorways enroute to installation site allow clearance for equipment?
- \_\_\_\_\_ 8. Will hallways and corridors enroute to installation site allow clearance for equipment?
- \_\_\_\_\_ 9. Are RFI sources or susceptible instruments nearby?

**Floor Plan.**

- \_\_\_\_\_ 10. Has grid layout been completed?
- \_\_\_\_\_ 11. Does it show the locations for all the proposed equipment?
- \_\_\_\_\_ 12. Does it allow for adequate clearance in front and rear of the combining case or cabinet for operation and service?
- \_\_\_\_\_ 13. Does it allow for future expansion?
- \_\_\_\_\_ 14. Is sufficient space provided for personnel safety, comfort and freedom of movement?
- \_\_\_\_\_ 15. Does it show locations of all doors and aisle ways?
- \_\_\_\_\_ 16. Is sufficient space provided for supplies?

**Electrical Power.**

- \_\_\_\_\_ 17. Have tests been conducted to determine the voltage and frequency fluctuations throughout the day?
- \_\_\_\_\_ 18. If tests indicated a greater than - 10% or + 5% fluctuation, have provisions been made for voltage or frequency regulation?
- \_\_\_\_\_ 19. Have provisions been made for the installation of a sufficient amount of receptacles throughout the site for free-standing equipment?
- \_\_\_\_\_ 20. Considering all factors such as wire size, distribution equipment, etc., is the proposed electrical installation plan adequate for the presently proposed system and possible future expansion?

**Temperature.**

- \_\_\_\_\_ 21. Has the installation area been checked for minimum and maximum temperature ranges of 0°C (32°F) to 55°C (131°F) respectively?

**Signal and Power Cables.**

- \_\_\_\_\_ 22. Have signal and power cable length restrictions been adhered to?
- \_\_\_\_\_ 23. Will cables other than those supplied with equipment be required?
- \_\_\_\_\_ 24. Will power plugs other than that supplied with equipment be required?

**Safety Precautions.**

- \_\_\_\_\_ 25. Has the need for emergency exits been considered?
- \_\_\_\_\_ 26. Have provisions been made for adequate number of CO<sub>2</sub> fire extinguisher?
- \_\_\_\_\_ 27. Is there a FIRST AID KIT available at the installation site?

## HP CONFIGURED SYSTEMS

### Standard HP-IB Measurement Systems (HP Built)

Application	Model	Controller	System name/characteristics
<b>Data Logging Acquisition, and Control</b>	3052A	9825/45	Automatic Data Acquisition: fast and precise low-level measurements, powerful computation
	3054A	85/9825 9826/9836 9845	Computer based Automatic Data Acquisition/Control System: fast flexible, and precise data acquisition system with a wide choice of controllers
	5391A	9825	Frequency and Time Data Acquisition Systems: over 50,000 four-digit frequency and time interval measurements per second
	9030	9825/45	Measurement and Control System: Fully configured, self-contained, and easy to use portable laboratory or production system for computational measurement and control.
	9875A	9825/45	Tape Cartridge Unit: Data logging applications
<b>Network Analysis</b>	3040A	9825	Network Analyzer: complete amplitude and phase characterization. 50 Hz to 13 MHz Group delay optional.
	3042A	9825	Automatic Network Analyzer: same as 3040A, and includes the 9825A as a computing controller
	8409C	9845/9826	Automatic Microwave Network Analyzers: measures transmission and reflection parameters, 110 MHz to 18 GHz.
	8507B/C	9825/45	Automatic RF Network Analyzers: measures complex impedance, transfer functions, group delay: 500 kHz to 1.3 GHz
<b>Spectrum Analysis</b>	3044A	9825	Spectrum Analyzer: precise amplitude and frequency measurements, 10 Hz to 13 MHz
	3045A	9825	Automatic Spectrum Analyzer: same as 3044A, and includes the 9825A as computing controller
	8581A	9825	Automatic Spectrum Analyzer: covers 100 Hz to 1.5 GHz — exceptional frequency tuning accuracy and resolution
	8582A	9825	Automatic Spectrum Analyzer: covers 100 Hz to 22 GHz; exceptional frequency tuning accuracy and resolution

(continued on next page)

Standard HP-IB Measurement Systems (HP Built)

Application	Model	Controller	System name/characteristics
<b>Frequency Stability Analysis</b>	5390A	9825	Frequency Stability Analyzer: short and long-term characterization of precision frequency sources, 500 kHz to 18 GHz
	3047A	9845/9836	Spectrum Analyzer System: high resolution and phase noise measurement.
<b>Transceiver Testing</b>	8953A	85/9826/9836	Transceiver Test Sets for AM and FM transceivers, 150 kHz to 990 MHz.
	8955A	9835/9845	RF Test System: for AM and FM transceivers, to 1000 MHz, transmitters to 120 W.
<b>Circuit Testing</b>	DTS-70	1000	Digital Test System: fast accurate fault location on loaded printed circuit boards
	3060A	9825	Analog and Digital Test Systems: Fast, accurate fault location on loaded printed circuit boards
<b>Digital IC Testing</b>	5046B	9826	Digital IC Test System: Reduces production costs through the isolation of faulty components prior to printed circuit board loading
<b>Network Surveillance</b>	3046A/B	85	Frequency Division Multiplex (FDM) network surveillance system: automatic capability based on HP-85.
<b>Semiconductor/Component Testing</b>	4061A	9845	Semiconductor/Component Test System: evaluation of fundamental characteristics of semiconductor and electronic components (I-V, HF C-V, + quasi static C-V)
<b>Pressure Recording Package</b>	2820B	9825	Pressure recording system: displays, prints, and records pressure test data from oil and gas wells. Used with the 2813B Quartz Pressure Probe.
<b>Graphics Display</b>	1350S	9825	Graphics Display System with Digital Interface. High resolution display system for generation of bright, sharp vectors and alphanumerics at high writing speeds
<b>Stimulus/Response Testing</b>	ATS-1000	1000	General Purpose Testing: Analog and Digital stimulus and, response for printed circuit boards and complete unit testing.



## Typical factory selected HP-IB addresses\* (not guaranteed)

PRODUCT RELATED TO	MODEL	HP-IB		PRODUCT NAME/CHARACTERISTICS
		DEC	OCT	
<b>Measurement</b>	436A Option 022	13	15	Power Meter - 70 dBm to +44 dBm, to 26.5 GHz
	1602A Option 001	15	17	Logic State Analyzer: 64 x 16 bit memory
	1610A/B Option 003	15	17	Logic State Analyzer: 64 x 32 bit memory
	1615A Option 001	15	17	Logic Analyzer: 256 x 24 bit memory
	1640A Option 001	16	20	Serial Data Analyzer: 2048 bit memory
	1980A/B	07	07	Oscilloscope Measurement System, 100 MHz, fully programmable
	2240A	01	01	Measurement & Control Subsystem
	2250A	30	36	Measurement & Control Subsystem
	2804A Option 010	13	15	Quartz Thermometer: 0.05°C accuracy
	3437A	24	30	System Digital Voltmeter: high speed, 3½ digits
	3438A	23	27	Digital Voltmeter: low-cost 3½ digits
	3455A	22	26	Digital Voltmeter: 5½ or 6½ digits, auto calibration
	3456A	22	26	Digital Voltmeter: 3½ to 6½ digit voltmeter with variable integration times and 1 nV sensitivity
	3490A Option 030	22	26	Digital Voltmeter: 5 digits, self test
	3582A	11	13	2-channel Real Time (FFT) Spectrum Analyzer: 20 MHz to 25.6 kHz
	3585A	11	13	Swept Spectrum Analyzer: 20 Hz to 40 MHz, 3 Hz BW, 0.5% amplitude accuracy
	3586A/B/C	16	20	Selective Level Meter: 50 Hz to 32.5 MHz
	3717A	01	01	Wideband 70 MHz modem
	3724/25/26A	06	06	Baseband Analyzer
	3745A	10	12	25 MHz Selective Level Measuring Set: CCITT FDM systems
	3745B	10	12	25 MHz Selective Level Measuring Set: Bell FDM systems
	3747A	10	12	90 MHz Selective Level Measuring Set: CCITT FDM systems
	3747B	10	12	90 MHz Selective Level Measuring Set: Bell FDM systems
	3771A Option 005	03	03	Data Line Analyzer: CCITT measurement standards
	3771B Option 005	03	03	Data Line Analyzer: Bell measurement standards
	3779A	20	24	Primary Multiplex Analyzer: CEPT 2 Mb/s PCM systems
	3779B	20	24	Primary Multiplex Analyzer: Bell 1.5 Mb/s PCM systems
	3781B	04	04	Pattern Generator
	3782B	03	03	Error Detector
	4140A/B Option 101	17	21	PA Meter/DC Voltage Source
	4191A	17	21	RF Impedance Analyzer
	4192A	17	21	LF Impedance Analyzer
	4262A Option 101	17	21	Automatic LCR Meter
	4271B Option 101	17	21	1 MHz Digital LCR Meter
	4274A Option 101	17	21	Multifrequency LCR Meter: 10 steps, 100 Hz to 100 KHz
	4275A Option 101	17	21	Multifrequency LCR Meter: 10 steps 10 kHz to 10 MHz
	4943A Option 010	10	12	Transmission Impairment Measurement System (TIMS)
	4944A Option 010	10	12	Transmission Impairment Measurement System (TIMS)
	5312A	10	12	HP-IB interface (Talker) for 5300B Counter System
	5316A	20	24	Universal Counter: 0-100 MHz
	5328A Option 011	25	31	Universal Counter: to 512 MHz, 10 ns time interval
	5335A	03	03	Automatic Universal Counter: 200 MHz/1.3 GHz 2ns Time Interval
	5340A Option 011	03	03	Automatic Microwave Counter: 10 Hz to 18 GHz
	5341A Option 011	03	03	Automatic Microwave Counter: high speed, to 4.5 GHz
	5342A Option 011	02	02	Automatic Microwave Counter: 10 Hz to 18 GHz
	5343A Option 011	07	07	Microwave Frequency Counter: 10 Hz to 26.5 GHz
	5345A Option 011, 012	18	22	General Purpose Plug-In Counter
	5353A	27	33	Channel C Plug-In for 5345A
	5354A	17	21	4 GHz Frequency Converter for 5345A/5356A
	5355A	09	11	Automatic Frequency Converter
5356A	06	06	Synthesized Signal Generator: 100 kHz to 990 MHz	
5363A/B	17	21	Time Interval Probes	
5370A	03	03	Time Interval Counter: ±20 ps single-shot resolution	
5420A	04	04	Digital Signal Analyzer	
5423A	04	04	Dynamics Structural Analyzer	
5501A Option 251	09	11	Laser Transducer: for accurate positioning measurements	
6940B	23	27	Multiprogrammer (requires 59500 interface)	
6942A	23	27	Multiprogrammer II (no interface required)	
8501A	19	23	Storage Normalizer for 8505A RF network analyzer	
8503A & 8503B	20	24	S-Parameter Test Set: 50 or 75 Ohm for 8505A	
8505A	19/16	23/20	RF Network Analyzer: 500 kHz to 1.3 GHz Service/Processor	
8566A	18	22	Spectrum Analyzer: 100 Hz to 22 GHz	
8568A	18	22	Spectrum Analyzer: 100 Hz to 1.5 GHz	
8901A	14	16	Modulation Analyzer: 150 kHz to 1.3 GHz	
8903A	28	34	Audio Analyzer: 20 Hz to 100 KHz	
			Also see models 2240A, 2250A, 6940B, 6942A, and 3497A	
<b>Storage</b>	3964A Option 007	17	21	Instrumentation Tape Recorder: 4 channel Listen only
	3968A Option 007	17	21	Instrumentation Tape Recorder: 8 channel Listen only
	9875A	04	04	Cartridge Tape Unit
<b>HP-IB Extension</b>	12050A/B	24	28	Fiber Optic Hp-IB link
	37201A	17	21	HP-IB Extender: Twisted Pair or modems
	37203A	NA	NA	HP-IB Extender: Co-axial or Fiber Optic Cable
	59403A	18/19	22/23	HP-IB Common Carrier Interface
<b>Design and Servicing</b>	59401A	NA	NA	Bus System Analyzer
	5004A Option Ho1	07	07	Signature Analyzer: Order K17-59994A for complete HP-IB
	10050A	NA	NA	HP-IB Adaptor for 1602A Logic State Analyzer
	10051A	NA	NA	Test Probe for 1602A Logic State Analyzer
	10066A	NA	NA	Probe Interface for 1610A/B and 1615A Logic State Analyzers

\*Because of space limitations this is a partial list.

PRODUCT RELATED TO	MODEL	HP-IB DEC	OCT	PRODUCT NAME/CHARACTERISTICS	
Stimulus	3320B Option 007	19	23	Frequency Synthesizer: 0.01 Hz to 13 MHz	
	3325A	17	21	Synthesizer/Function Generator/Sweeper: 1 GHz to 22 MHz	
	3330B	04	04	Automatic Synthesizer/Sweeper: 0.1 Hz to 13 MHz	
	3335A	04	04	Synthesizer/Level Generator: 200 Hz to 80 MHz	
	3336A/B/C	04	04	Synthesizer/Level Generator: 10 Hz to 20.9 MHz	
	4140A/B	14	16	PA Meter/DC Voltage Source	
	5359A	04	04	Time Synthesizer: 1 ns accuracy; 50 ps increments; 100 Ps jitter	
	6002A Option 001	05	05	DC Power Supply: 200 W autoranging Listen Only	
	6129C Option J99	16	20	Digital Voltage Sources: $\pm 50$ Vdc at 5 A (requires 59301A Converter)	
	6130C Option J99	16	20	Digital Voltage Source: $\pm 50$ Vdc at 1 A (requires 59301A Converter)	
	6131C Option J99	16	20	Digital Voltage Source: $\pm 100$ Vdc at 0.5 A (requires 59301A Converter)	
	6140A Option J99	16	20	Digital Current Source: $\pm 100$ mA at 100 Vdc (requires 59301A Converter)	
	6940B	23	27	Multiprogrammer (requires 59500A interface)	
	6942A	23	27	Multiprogrammer	
	8016A Option 001	17	21	Word Generator: 9 x 32 bit Listen Only	
	8018A Option 001	17	21	Serial Data Generator: 50MHz, 2048-bit memory Listen Only	
	8160A	17	21	Programmable Pulse Generator: 20 ns to 999 ms period	
	8161A	17	21	Programmable Pulse Generator: 10 ns to 999 ns period	
	8165A	15	17	Programmable Signal Source: 0.001 Hz to 50 Mhz	
	8170A	17	21	Logic Pattern Generator: 8 x 1024/16 x 512 bit	
	8350A	19	23	Sweep Oscillator: 10 MHz to 26.5 GHz	
	8620C Option 011	06	06	Sweep Oscillator: 10 MHz to 22 GHz	
	8656A	07	07	Signal Generator: 0.1 to 990 Mhz	
	8660A Option 005	19	23	Synthesized Signal Generator: 10 kHz to 2.6 GHz Listen Only	
	8660C Option 005	19	23	Synthesized Signal Generator: 10 kHz to 2.6 GHz Listen Only	
	8662A	19	23	Synthesized Signal Generator: 10 kHz to 1280 MHz	
	8671A	19	23	Microwave Frequency Synthesizer: 2 to 6.2 GHz	
	8672A	19	23	Synthesized Signal Generator: 2 to 18 GHz	
	Display	1350S	18	22	Graphics Display System
		2631A/G	05	05	Graphics Thermal Printer
		5150A Option 001	00	00	Alphanumeric Thermal Printer: 20 Columns Listen Only
		9871A Option 001	15	17	Character-Impact Printer: 132 columns
		7225A	05	05	Graphic Plotter: ISO A4 and 8 1/2 x 11 inch chart size
7245B		05/06	05/06	Thermal Plotter/Printer: Vector graphics, matrix printing	
7310A		01	01	Graphics Thermal Printer: Text, Graphics, and Forms	
9872B, 9872S		05	05	Graphics Plotter: multicolor (4 colors) programmable	
9876A		16	20	Thermal Graphics Printer: 480 lines-per-minute	
Switching Scanning Translation or Timing		2240A	01	01	Measurement and Control Subsystem
	2250A	30	36	Measurement & Control Subsystem	
	3495A	09	11	Scanner: to 80 channels, low thermal: (up to 40 relay channels) Listen Only	
	3497A	09	11	Data Acquisition 1 Control Unit	
	3754A	30	36	25 MHz Access Switch (requires 3755A switch controller)	
	3756A	30	36	90 MHz Switch (requires 3755A)	
	3757A	30	36	8.5 MHz Access Switch (requires 3755A)	
	3777A	01	01	Telecommunications Channel Selector: up to 30 channels: dc to 110 kHz	
	6940B	23	27	Multiprogrammer (requires 59500A interface)	
	6942A	23	27	Multiprogrammer II (no interface required)	
	9411A	*	*	Switch Controller	
	9412A	*	*	Modular Switch (requires 9411A switch controller)	
	9413A	*	*	VHF Switch (requires 9411A)	
	9414A	*	*	Matrix Switch (requires 9411A)	
	11713A	28	34	Attenuator/Switch Drive (controls coax switches and step attenuators)	
	12050A/B	24	30	Fiber Optic HP-IB Link	
	37201A	17	21	HP-IB Extender: Twisted Pair Pistons	
	37203A	NA	NA	HP-IB Extender: Coax and Fiber Optics	
	59301A	16	20	ASCII to Parallel Converter: string to 16 characters	
	59303A	02	02	Digital to Analog Converter	
	59306A	16	20	Relay Actuator for programmable switches, attenuators	
	59307A	16	20	VHF Switch two 50 Ohm, bidirectional, dc to 500 MHz	
59308A	09	11	Timing Generator		
59309A	26	32	Digital Clock: month, day, hour, minute, second		
59313A	12	14	Analog to Digital Converter		
59403A	18/19	22/23	HP-IB Common Carrier Interface: RS232C or CCITT V24		
59500A	23	27	Multiprogrammer (6940B) HP-IB Interface		
59501A	06	06	Power Supply Programmer: isolated D to A converter — 10 V dc at 10 mA		
Control and Computation	85A/F	21	25	Personal Computer (uses 82937A Interface)	
	9815A/S	21	25	Desktop Computer (uses 98135A Interface)	
	9825B/T	21	25	Desktop Computer (uses 98034A Interface)	
	9835A/B	21	25	Desktop Computer (uses 98034A Interface)	
	9845B/T	21	25	Desktop Computer System 45 (uses 98034A Interface)	
	9915	21	25	Modular Desktop Computer (uses 82937A Interface)	
	HP1000 M series	00	00	Computers (2105A, 2108M & 2112M, use 59310B Interface)	
	HP1000 E series	00	00	Computers (2109E & 2113E, use 59310B Interface)	
	HP1000 F series	00	00	High performance computers (2111F and 2117F use 59310B Interface)	
	HP1000 L series	30	36	Low Cost Computer (2103, uses 12009A Interface)	
	3075A Option 011	*	*	Desktop Data Capture Terminal (secondary interface for local printer/plotter functions)	
	3076A Option 011	*	*	Wall Mounted Data Capture Terminal (secondary interface for local printer/plotter functions)	
	Cabling	10631A	NA	NA	HP-IB Interconnection Cable: 1 m (3.3 ft)
10631B		NA	NA	HP-IB Interconnection Cable: 2 m (6.6 ft)	
10631C		NA	NA	HP-IB Interconnection Cable: 4 m (13.2 ft)	
10631D		NA	NA	HP-IB Interconnection Cable: 0.5 m (1.6 ft)	
10833A		NA	NA	HP-IB Interconnection Cable: 1 m (3.3 ft)	
10833B		NA	NA	HP-IB Interconnection Cable: 2 m (6.6 ft)	
10833C		NA	NA	HP-IB Interconnection Cable: 4 m (13.2 ft)	
10833D		NA	NA	HP-IB Interconnection Cable: 0.5 m (1.6 ft)	
10834A		NA	NA	HP-IB Interconnection Cable Adaptor: 2.3 cm (.91 in)	

\*No typical value, depends on configuration, assume it is set randomly

NA — No HP-IB address is required, the device is totally transparent or has strictly talk or listen only capabilities.



## Quiz Yourself

### Questions regarding the IEEE-488/ANSI MC1.1/IEC 625-1 standards

- Circle those areas defined by the IEEE-488/ANSI MC1.1 standards
  - Functional
  - Electrical
  - Mechanical
  - Operational
  - All of the above
  
- Circle those that apply to the IEEE-488/ANSI MC1.1
  - Asynchronous
  - Synchronous
  - Bit-Parallel, Byte-Serial
  - Bit-Serial, Byte-Parallel
  - Totally compatible with the IEC 625-1 Part 1 standard
  
- On a single contiguous bus (no extension) what are the IEEE-488/ANSI MC1.1 IEC 625-1 limitations as to:
  - Number of devices on each contiguous bus?\_\_\_\_\_
  - Cable length on each contiguous bus?\_\_\_\_\_
  - Maximum data transmission rate?\_\_\_\_\_
  - Maximum number of active talkers at one time?\_\_\_\_\_
  - Maximum number of active listeners at one time?\_\_\_\_\_
  - Maximum number of primary (one-byte) addresses available?\_\_\_\_\_
  - Maximum number of extended (two-byte) addresses available?\_\_\_\_\_
  
- The logic convention used on the HP-IB is:
  - Positive-true logic with positive polarity
  - Negative-true logic with positive polarity
  - Negative-true logic with negative polarity*
  - Positive-true logic with negative polarity
  
- Data is transferred over the data bus as:
  - 5-bit BAUDOT code
  - 7-bit ASCII/ISO code
  - 8-bit ASCII/ISO code
  - EBCDIC
  - 8 binary bits typically ASCII/ISO encoded

6. Circle those that apply to the 3-wire handshake sequence:
  - A. NRFD and NDAC are wired-or'ed and shared by all active listeners.
  - B. Every data-byte transferred over the data bus is hand shook.
  - C. The NDAC line is released by a listener *only* after the byte has been acted on by the device (e.g., triggered).
  - D. Hewlett-Packard does hold patents on the 3-wire handshake technique.
  
7. When ATN is low (true) the HP-IB is in which transfer mode?
  - A. Command (can send addresses only)
  - B. Command (can send commands and addresses)
  - C. Data (can send commands and device-dependent data)
  - D. Data (can send only device-dependent data)
  
8. How many bits are required for a complete talk/listen address code?
  - A. 8
  - B. 7
  - C. 5
  - D. 3
  
9. In a system without a controller, how are devices addressed?
  - A. The talker uses ATN and sends addressed commands over the Data Bus in the command mode.
  - B. No addressing is needed.
  - C. "Talk Only" and "Listen Only" switches on the devices are set to configure the system (if they exist).
  
10. What is the difference between DCL and SDC?
  - A. DCL can only be sent by a controller whereas SDC can be sent by a talker.
  - B. DCL clears all clearable devices while SDC clears only the clearable devices which are active listeners.
  - C. DCL takes more steps to implement (longer).
  
11. To simultaneously trigger a group of devices over the HP-IB, the controller:
  - A. Sends GET in the Command mode (ATN true).
  - B. Addresses the desired devices to listen and sends GET in the Command mode.
  - C. Addresses the desired devices to listen and sends each a device-dependent trigger message.
  - D. Either B or C.

12. The LLO multiline command:
- A. Disables all local controls on a device.
  - B. Disables the front-panel "local" pushbutton on a device.
  - C. Is cleared when the device goes to the local mode of operation by GTL in the Command mode.
  - D. Is cleared when REN goes false.
  - E. Both B and D above.
13. Which general bus interface management lines can be activated by devices which are talkers or listeners?
- A. ATN, REN, SRQ.
  - B. EOI, SRQ.
  - C. None.
14. Which general bus interface management lines can be activated by only the system controller?
- A. IFC, ATN, REN
  - B. IFC, REN
  - C. IFC
15. Can a listen-only device request service?
- A. No, only talkers can request service.
  - B. Yes, if the device has only one condition which would require service, it could activate SRQ (no talk function is needed because no status byte is required).
  - C. Yes, devices with Parallel Poll capabilities can indicate the need for service if polled by the controller. This differs from the use of the SRQ to request service since the controller initiates the poll.
  - D. Both B and C.
16. What are the advantages of serial polling compared to parallel polling?
- A. *The device has the initiative of requesting service via the SRQ line.*
  - B. Serial polling is faster for between 2 and 8 devices.
  - C. The nature of the request is obtained concurrently with the identity of a requestor.
  - D. A, B, and C.
  - E. Both A and C.

17. Black fasteners on the IEEE-488/ANSI MC1.1 mean:
  - A. Metric threads but you can mate to silver (English) fasteners.
  - B. Metric threads which should not be mated to silver (English) fasteners.
  - C. English threads which should not be mated to silver (metric) fasteners.
  - D. An RS-232-C type 25-pin connector is used.
  
18. To achieve the 1 M byte/sec transfer rate, you:
  - A. Must have every device turned on and tri-state drivers in every device participating in the transfer.
  - B. Must not exceed 15 meters total cable length or one device per meter of cable, whichever is less.
  - C. Must limit the capacitive load per device to less than 50 pf.
  - D. Must use a bus extension device.
  
19. The 1978 Revision to the IEEE-488/ANSI MC1.1 Standard:
  - A. Was about 90% editorial clarification.
  - B. Was a major revision to accommodate modern low-power Schottky technology.
  - C. Included a mandatory requirement to mark device's interface capability I.D. codes on the product exterior.
  - D. Made it compatible with the IEC 625-1 Standard.

### **Questions regarding HP-IB system design**

1. If you have more than 15 devices (including controller, no bus extension required), you can:
  - A. Add an interface until you run out of available I/O slots.
  - B. Use extended addressing.
  - C. Usually add I/O slots via an I/O expander.
  - D. A and/or C as required.
  
2. To surpass the 20 meter total cable-length restriction you can:
  - A. Run 2 interfaces in parallel (add an additional HP-IB interface card).
  - B. Use an intra-facility extension technique for requirements below 1000 meters.
  - C. Use an inter-facility extension technique for requirements above 1000 meters.

3. An IEEE-488/ANSI MC1.1/IEC 625-1 Bus Analyzer or a general purpose Timing and State Analyzer are useful tools for:
  - A. The System Designer when designing HP-IB compatibility into a product, test fixture, or user interface or when adding HP-IB compatibility to a non-HP-IB device (e.g., environmental chamber, BCD device, etc.).
  - B. The System Programmer when developing, analyzing, optimizing, or debugging the performance of his systems operating system, specialized device or instrument driver, or other applications where interface characterization may be important.
  - C. The System Technician when troubleshooting a system built upon an IEEE-488/ANSI MC1.1/IEC 625-1 interface standard.
  
4. A Serial Bus Analyzer is a useful tool for:
  - A. The System Designer when designing a serial interfacing scheme into his or her HP-IB Instrumentation System.
  - B. The System Programmer when communicating over a serial interfacing scheme in his or her HP-IB Instrumentation System.
  - C. The System Technician when troubleshooting the serially interfaced portion of an HP-IB Instrumentation System.
  
5. Circle those system components which could degrade or limit the maximum achievable transfer rate of your interface system:
  - A. Resolution or accuracy of a measurement.
  - B. Bandwidth of a measurement.
  - C. Type of data format chosen on an instrument.
  - D. Distribution of computation in the system.
  - E. Availability of hardware-controllable features on devices.
  - F. The cabling arrangement.
  - G. The device's processor, MPU, or state machine logic.
  - H. The use of bus extenders.
  - I. The data format expected and/or used by the computer.
  - J. The Software Language and Language-level chosen.
  - K. Choosing IEEE-488/ANSI MC1.1 implementation versus an IEC 625-1 implementation.

## Interactive answers to “Quiz Yourself”

### Regarding the IEEE-488/ANSI MC1.1/IEC 625-1 standards

1. A, B, C    The operational area is beyond the scope of these standards. The IEC 625-2 Standard does provide Part 2 to its standard “Part 2: Code and Format Conventions” which are recommended practices rather than mandatory specifications for the interface system. Similarly, the IEEE and ANSI have their Recommended Practices.
2. A,C        E is not true due to the different connectors utilized.
3. A.         15 devices including the controller.  
B.         20 meters total or 2 meters per device, whichever is less.  
C.         1 Megabyte/second is the theoretical limit.  
D.         Only 1 device can be an active Talker. When a device is addressed to Talk all other devices automatically Untalk. A universal Untalk command (ASCII/ISO “-”) is also provided for convenience.  
E.         Up to 14 devices can listen.  
F.         There are 31 available primary Talk and Listen addresses. 0-30 are available, 31 is reserved for the Universal Untalk and Universal Unlisten commands.  
G.         There are 961 available extended Talk and Listen addresses. The secondary address byte squares the number of available addresses and has the same restrictions.
4. B.         Negative true logic with a positive polarity is used on all 16 active lines. This allows for an efficient and fast wired-or convention on the shared acceptor handshake lines NRFD, NDAC and also serves to provide a passive “high=false” state on all 16 lines while retaining low-noise susceptibility in the “low=true” state when they appear as low impedances to ground.
5. B,E.        A full 8 bits is available for sending information. Typically the information is 7 bit ASCII/ISO encoded.



6. A,B,D      C is not true. That is up to the choice of the device or instrument designer. Newer devices may offer programming modes for holding a handshake sequence by a "busy-line" condition or for fast handshake of listener-dependent data from a talker. Others offer hardware signals to indicate the message has been acted on (e.g., Voltmeter Complete, Data Ready, etc.).
7. B.          Addresses are commands too. Devices respond to commands while in the command mode, this includes DCL, SDC, and GET.
8. B.          Bits 1 through 5 set the devices address but bits 6 and 7 are used to designate between the Talk and Listen addresses.
9. C.          Devices must have a hardware means of being set and cleared of their "Talk Only" or "Listen Only" functions.
10. B          SDC requires addressing steps by definition. This typically can take longer to implement especially since most devices would look for the universal command DCL first while the interface is in the Command mode.
11. B.          The GET addressed command is the only strictly software way to do this.
12. E.          The pushbutton is disabled even if the device or instrument then receives the GTL addressed command and then returns to remote control via its listen address along with the REN uniline command. The only way to clear the LLO condition is by placing the interface in a Local mode with REN false.
13. B.
14. B.          ATN can be activated by any controller to send addressing information.

15. D. Any device can activate the SRQ line. Not all devices can be Serial or Parallel polled. To have Serial poll capabilities a device must have a Talker function to send a status byte. However, the Parallel-Poll technique can inherently request service from the controller regardless of the devices Talker capabilities. This requires that the device has Parallel-Poll capabilities and that the controller does initiate the parallel poll.
16. E. The entire parallel-poll procedure must occur in under 2 micro-seconds, whereas a serial poll would require many steps to guarantee success. A mixture of serial and parallel polling is sometimes used.
17. B. Watch out for those silver fasteners!
18. A,B,C.
19. A Most of the changes constituted addendum (clarification and expansion) and some errata (anomalies).

## Regarding HP-IB system design

1. D. Again, more than 15 devices constitutes a fairly extensive system. You should find your I/O slot and expansion capabilities adequate in most quality desktop or minicomputers.
2. B,C. A should never be attempted. B and C allows you to expand via HP-IB extenders. However, you are still restricted to 20 meters total cable length up to the extender.
3. A,B,C. Whether you're designing, programming, or troubleshooting an HP-IB based measurement system or subsystem, a dedicated or general-purpose bus analyzer is a useful tool. They are especially useful when characterizing the handshake times of HP-IB compatible system components as part of an overall throughput analysis.
4. A,B,C. If your system occupies the role of a measurement node in a larger distributed system environment, you may have a need for a serial interface for one or more of the following reasons:
  - Bus extension (INTRA FACILITY and INTER-FACILITY)
  - Adding RS-232-C/CCITT V24 compatible but non-IEEE-488/ANSI MC1.1/IEC 625-1 components.
  - Communicating over a noisy environment (transformers, arc-welding, inductive power systems, etc.).
  - Terminal Emulation (ASYNCHRONOUS).
  - Remote Job Entry (RJE) (SYNCHRONOUS).
  - Factory Data Collection over a Factory Data Link (FDL).
  - Other Data Communications and Distributed Systems Applications.A serial link analyzer is an important design, programming, and service tool for these applications.
5. A-J K is the only system component which would not limit the transfer rate of the interface system directly. Whether you choose an IEEE-488/ANSI MC1.1 or IEC 625-1 implementation the theoretical maximum rate on your interface would be the same.

## **Glossary of HP-IB related terms**

“To help you interpret the Standards and other Information Sources”

**ACCEPTOR**—A device receiving information on the Bus in either the Command or Data Mode. (Also, see Source.)

**ADDRESS**—A 7-bit code applied to the HP-IB in “Command Mode” which enables instruments capable of responding to listen and/or talk on the Bus.

**ADDRESSED COMMANDS**—These commands allow the Bus controller to initiate actions from addressed instruments which are capable of responding.

**ATN**—Control line (Attention) establishes between the “Command Mode” and “Data Mode” of operation on the HP-IB.

**BIDIRECTIONAL BUS**—A bus used by any individual device for two-way transmission of messages, that is, both input and output.

**BIT**—The smallest part of a binary character which contains intelligible information. A Binary Digit.

**BIT-PARALLEL**—Refers to a set of concurrent data bits present on a like number of signal lines used to carry information. Bit-parallel data bits may be acted upon concurrently as a group (byte) or independently as individual data bits.

**BUS**—A signal line or a set of signal lines used by an interface system to which a number of devices are connected and over which messages are carried.

**BUS COMMANDS**—A group of ASCII Codes which initiate certain types of operation in devices capable of responding to these codes. Each instrument on the HP-IB is designed to respond to those codes that have useful meaning to the device and ignore all others.

**BYTE**—The binary character sent over the data bus. Although a byte usually refers to 8 bits, frequently the eighth bit is a don't care in an HP-IB system.

**BYTE-SERIAL**—A sequence of bit-parallel data bytes used to carry information over a common bus.

**COMMAND MODE**—In this mode devices on the HP-IB can be addressed or unaddressed as talkers or listeners. Bus commands are issued in this mode.

**COMPATIBILITY**—The degree to which devices may be interconnected and used, without modification.

**CONTROLLER**—Any device on the HP-IB which is capable of setting the ATN line and addressing instruments on the Bus as talkers and listeners. (Also see System Controller.)

**DEVICE CLEAR (DCL)**—ASCII character “DC4” (Octal 024) which, when sent on the HP-IB will return all devices capable of responding to predefined states.

**DATA MODE**—The HP-IB is in this mode when the control line “ATN” is high (false). In this mode data or instructions are transferred between instruments on the HP-IB.

**DAV**—Mnemonic referring to the control line “Data Valid” on the HP-IB. This line is used in the HP-IB “Handshake” sequence.

**DIO**—Mnemonic referring to the eight “Data Input/Output” lines of the HP-IB.

**DRT**—Device Reference Table, on HP 1000 symbol table which equates a Logical Unit Number to an EQT entry.

**EOI**—Mnemonic referring to the control line “End or Identify” on the HP-IB. This line is used to indicate the end of a multiple byte message on the Bus. It is also used in parallel polling.

**EQT**—Equipment Table, an HP 1000 symbol table which equates a specific EQT number to a driver, select code, or other I/O information.

**EXTENDED LISTENER**—An instrument which can use two HP-IB bytes to address it as a listener. (Also see Listener.)

**EXTENDED TALKER**—An instrument which can use two HP-IB bytes to address it as a talker. (Also see Talker.)

**GO TO LOCAL (GTL)**—ASCII character “SOH” (Octal 001) which, when sent on the HP-IB, will return devices addressed to listen and capable of responding back to local control.

**GROUP EXECUTE TRIGGER (GET)**—ASCII character “BS” (Octal 010) which, when sent on the HP-IB, initiates simultaneous actions by devices addressed to listen and capable of responding to this command.

**HANDSHAKE**—Refers to the sequence of events on the HP-IB during which each data byte is transferred between addressed devices. The conditions of the HP-IB handshake sequence are as follows:

- a. NRFD, when false, indicates that a device is ready to receive data.
- b. DAV, when true, indicates that data on the DIO lines is stable and available to be accepted by the receiving device.
- c. NDAC, when false indicates to the transmitting device that data has been accepted by the receiver.

**HIGH STATE**—The relatively more positive signal level used to assert a specific message content associated with one or two binary logic states.

**HP-IB**—An abbreviation that refers to the “Hewlett-Packard Interface Bus.”

**IBLU**—(Integer) Bus Logical Unit. An HP 1000 mnemonic for the LU of the HP-IB interface.

**IDLU**—(Integer) Device Logical Unit. An HP 1000 mnemonic for the LU of the HP-IB device.

**IFC**—General Interface Management Line “Interface Clear” used by the system controller to halt all current operations on the bus, unaddress all other devices, and disable Serial Poll.

**INTERFACE**—A common boundary between a considered system and another system, or between parts of a system, through which information is conveyed.

**INTERFACE SYSTEM**—The device-independent mechanical, electrical, and functional elements of an interface necessary to effect communication among a set of devices. Cables, connector, driver and receiver circuits, signal line descriptions, timing and control conventions, and functional logic circuits are typical interface system elements.

**LISTENER**—A device which has been addressed to receive data or instructions from other instruments on the HP-IB. (Also see Extended Listener.)

**LOCAL CONTROL**—A method whereby a device is programmable by means of its local (front or rear panel) controls in order to enable the device to perform different tasks. (Also referred to as manual control.)

**LOCAL LOCKOUT (LLC)**—An HP-IB multiline universal command which disables the (ASCII character “OCI” Octal 021) return-to-local control (pushbutton) on a device (prevents user from leaving remote control other than cycling power). Clearing the REN line of the HP-IB restores local control and re-enables the return-to-local pushbutton on every HP-IB device.

**LOW STATE**—The relatively less positive signal level used to assert a specific message content associated with one of two binary logic states.

**LU**—Logical Unit.

**NDAC**—Mnemonic referring to the control line “Not Data Accepted” on the HP-IB. This line is used in the “Handshake” sequence.

**NRFD**—Mnemonic referring to the control line “Not Ready for Data” on the HP-IB. This line is used in the HP-IB “Handshake” sequence.

**PARALLEL POLLING**—A method of simultaneously checking status of instruments on the HP-IB. Each instrument is assigned a DIO line with which to indicate whether it requested service or not. More than one instrument can be connected to one data line.

**PRIMARY COMMANDS**—The group of multiline messages consisting of universal commands, addressed commands, and device addresses sent by a CONTROLLER in the COMMAND MODE (ATN true).

**PROGRAMMABLE**—*The characteristic of a device that makes it capable of accepting data to alter the state of its internal circuitry to perform a specific task(s).*

**PROGRAMMABLE MEASURING APPARATUS**—A measuring apparatus that performs specified operations on command from the system and, may transmit the results of the measurement(s) to the system.

**REMOTE CONTROL**—A method whereby a device is programmable via its electrical interface connection in order to enable the device to perform different tasks.

**REN**—Mnemonic referring to the control line "Remote Enable" on the HP-IB. This line is used to enable Bus compatible instruments to respond to commands from the controller or another talker. It can be issued only by the system controller.

**SECONDARY COMMANDS**—The group of multiline messages used to increase the command address length of extended talkers and listeners to two bytes.

**SELECTIVE DEVICE CLEAR**—ASCII character "EOT" (Octal 004) which returns selected devices to a predetermined state.

**SERIAL POLLING**—The method of sequentially determining which device connected to the HP-IB has requested service. Only one instrument is checked at a time.

**SERIAL POLL DISABLE (SPD)**—ASCII character "EM" (Octal 031) which, when sent on the HP-IB, will cause the Bus to go out of serial poll mode.

**SOURCE**—A device transmitting information on the Bus in either the Command or Data Mode (also see Acceptor).

**SIGNAL**—*The physical representation of information.*

**SIGNAL LEVEL**—The magnitude of signal compared to an arbitrary reference magnitude (voltage in the case of this standard).

**SIGNAL LINE**—One of a set of signal conductors in an interface system used to transfer messages among interconnected devices.

**SIGNAL PARAMETER**—That parameter of an electrical quantity whose values or sequences of values convey information.

**SYSTEM**—A set of interconnected elements constituted to achieve a given objective by performing a specified function.

**SRQ**—Mnemonic referring to the control line “Service Request.” This control line is used to enable Bus compatible instruments to tell the controller that they service.

**TERMINAL UNIT**—An apparatus that terminates the considered interface system and by means of which a connection (and translation, if required) is made between the considered interface system and another external interface system.

**UNIDIRECTIONAL BUS**—A bus used by an individual device for one-way transmission of messages only, that is, either input only or output only.

**WORD**—A group of “characters” treated as a unit and given a single location in memory (organization defines the length of a computer “word”). HP computers typically use a word oriented memory with 16-bit (2 byte) words.

**UNIVERSAL COMMAND**—These commands allow the controller to send specific messages to all devices with the capability of recognizing them, whether or not the devices are addressed.





## Hewlett-Packard HP-IB Bibliography

### General HP-IB

PUBLICATION #	DESCRIPTION
AN-201-4	Performance Evaluation of HP-IB using RTE Operating Systems, Revised.
AN-201-6	Desktop-Minicomputer Communications
AN-201-7	High-performance software for the HP 3455A/3495A Subsystem
AN-201-8	The Use of Device Subroutines with HP-1000 Computers
AN-290	Practical Temperature Measurements (Thermocouples, RTD's, Thermistors, IC Transducers).
AN-401-1	HP-1000 M,E,F/HP-IB Programming Procedures (P/N 5953-2800). First of a continuing series.
AN-401	Index for AN 401 Series HP 1000/HP-IB Programming, Programming Notes
03052-90032	Pre-study Manual: 9825
03052-90205	Pre-study Package: 9835A
03052-90230	Pre-study Package: 9845A
03054-91501	Introductory Guide: 85
03054-92501	Introductory Guide: 9825
03054-93501	Introductory Guide: 9835
03054-94501	Introductory Guide: 9845
5952-0056	Hewlett Packard Measurement and Computation Help Improve Productivity
5952-0070	HP-IB and the 9835A
5952-0078	HP-IB Brochure (English)

PUBLICATION #	DESCRIPTION
5952-8834	Precision Instrumentation for Data Acquisition.
5952-8799	Financial Justification: Circuit Test Systems
5952-90056	HP-IB with the 9825 Calculator
5953-0904	Data Acquisition and Control with the System 45
5953-0979D	System 35 Technical Supplement: Assembly Language
5953-0985	I/O Supplement for the System 35
5953-1001	HP Enhanced BASIC
5953-0786	Calculators User's Club
5953-1048	Desktop Computer Applications in Industry
5953-1085	Consumables
5953-1050	Peripherals
5953-1087	Quality
5953-1083	BASIC User's Club
5953-1090	Data Acquisition and Control
5953-1094	HP 6940/9825 Automatic Test Measurement, and Control System
5953-2450	Computer Supplies: Spring 1980
5953-3088	HP 1000 Automatic Test Applications
5953-3318	HP Computer Systems Support Services Data Book
5953-3866D	Do Your Own System Design in Weeks, Instead of Months
5953-4212	DS/1000 Applications Brochure
5953-4224	Data Cap/1000
5953-4227	Fiber Optic HP-IB Link Product
5953-4247	ATS/1000 Integration Services Configuration Guide
5953-4513	System 35/45 Programming Language
5955-0961	HP-IB Instruments
09825-90060	Interfacing Concepts and the 9825A

PUBLICATION #	DESCRIPTION
09835-90600	BASIC Language Interfacing Concepts
12009-90001	HP 12009A HP-IB Interface Reference Manual (for HP 1000 L-Series)
59300-90005	HP-IB Programming Hints for Selected Instruments: 9825A
59310-90064	The HP-IB in HP 1000 Computer Systems Users Manual
59310-90063	RTE Driver DVR 37 for HP 59310B Interface Bus Programming & Operation Manual
59310-90068	59310B Bus Input/Output Interface Kit Operation & Service Manual
59401-90030	Condensed Description of the Hewlett Packard Interface Bus
92070-90011	RTE-L Driver Reference Manual (for HP 1000 L-Series)

NOTE: There is an extensive list of HP Quick Reference Guides and Programming Notes that is more extensive than can be shown here. Contact your nearest HP office for more details.



## Hewlett-Packard HP-IB Bibliography

### HP-IB Device/System Model Number

MODEL NUMBER	DESCRIPTION	DOCUMENT
11713A	Attenuator/ Switch Driver	Programming Note: Introductory Operating Guide for the 11713A Attenuator/Switch Driver with the 9825A Desktop Computer (5952-8215)  Programming Note: Introductory Operating Guide for the 11713A Attenuator/Switch Driver with the 9835 Desktop Computer (5952-8231)
1350A	Graphics Translator	AN 271-1 Instrumentation Graphics Adding soft copy graphics to 9825A based HP-IB systems using the model 1350A Graphic Translator  10184A Software Library Contains binary routine to make 1350A look like 9872A (HP-GL)
1615A	Logic Analyzer	1615A/9825A Introductory Operating Guide
2240A	Measurement & Control Processor	HP 2240A Measurement and Control Processor —Technical Data (5952-8542)  HP 2240A Measurement and Control Processor — Extended Performance Option Technical Data Supplement (5953-3091)  HP 2240A Measurement and Control Processor — Measurement and Control Examples App Note 224-1 (5952-8547)
2631A	Matrix Printer	Installation Note: HP 2631A Printer, HP 9825A Calculator (09825-9007)
3042A	Network Analyzer	AN 205-1 Network Analysis with HP-IB Systems Low Frequency Amplitude Considerations of 3042 Systems  AN 205-2 Network Analysis with HP-IB Systems Sonar Transducer Calibration
3052A	Automatic Data Acquisition System	Technical Data Sheet, Nov. 1979 (5952-8822) gives useful system throughput information

MODEL NUMBER	DESCRIPTION	DOCUMENT
3054A	Automatic Data Acquisition/Control System (See General HP-IB)	Pre-Study Packages Technical Data Sheet, May 1980, (5952-8825) useful system throughput information Introductory Guides, Ap-Note, etc. (See General HP-IB)
3325A	Synthesizer/Function Generator	Application Guide for the 3325A Synthesizer/Function Generator (P/N 5952-8771) AN-401-13 3325 Function Generator/HP 1000 Computer (P/N 5953-2812)
3335A	Synthesizer/Level Generator	9825A/SLM User's Guide (P/N 5952-3222)
3336A/B/C	Synthesizer/Level Generator	User's Guide: Using the HP 3586A, B, & C Selective Level Meter and HP 3336A, B, & C Synthesizer/Level Generator (5952-8821)
3437A	System Voltmeter	HP-IB programming hints for selected instruments, 9825A (P/N 59300-90005) AN 401-10 3437A Digital Voltmeter/HP 1000 M,E,F Computer (P/N 5953-2809)
3438A	Digital Multimeter	HP-IB programming hints for selected instruments, 9825A (P/N 59300-9000) AN-401-6 3438A Digital Multimeter/HP 1000 M,E,F Computer (P/N 5953-2805)
3455A	Digital Voltmeter	HP-IB Programming Hints for selected instruments, 9825A (P/N 59300-90005) AN 401-7 3455A Digital Multimeter/HP 1000 M,E,F Computer (P/N 5953-2806)
3456A	Digital Voltmeter	Introductory Users Guide, April, 1980 (P/N 03456-90002) Technical Data Sheet, May 1980 (P/N 5952-8830D) Has useful system throughput information Introductory Operating Guide (P/N 5952-2911)
3497A	Data Acquisition/Control Unit	AN-401-22 3497A Data Acquisition/Control Unit/HP 1000 M,E,F,L Computer (P/N 5953-2821) Introductory User's Guide, April, 1980, (P/N 03497-90001) Quick Reference Guide (03497-90002)

MODEL NUMBER	DESCRIPTION	DOCUMENT
3495A	Scanner	HP-IB Programming Hints for selected instruments, 9825A (P/N 59300-90005) AN-401-11 3495A Scanner/HP 1000 Computer (P/N 5953-2810)
3571A	Spectrum Analyzer	HP-IB Programming Hints for selected instruments, 9825A (P/N 59300-90005)
3582A	Spectrum Analyzer	Understanding the 3582A Spectrum Analyzer (P/N 5952-8773) AN-245-1 Signal Averaging with the HP 3582A Spectrum Analyzer AN-245-2 Measuring the Coherence Function with the HP 3582A Spectrum Analyzer AN-245-3 Third Octave Analysis with the HP-3582A Spectrum Analyzer AN-245-4 Accessing the 3582A Memory with HP-IB AN-245-5 Log Sweep with the HP 3582A Spectrum Analyzer AN-401-12 3582A Spectrum Analyzer/HP 1000 M,E,F Computer (P/N 5953-2811)
3585A	Spectrum Analyzer	AN-246 Using the HP 3585A Spectrum Analyzer with the HP 9825A Computing Controller
3586A/B/C	Selective Level Meter	Using the HP 3586A, B & C Selective Level Meter and HP 3336A, B & C Synthesizer/Level Generator (5952-8821)
3745/47/A/B	Selective Level Measuring Set	9825A/SLMS User's Guide (P/N 5952-3222)
3754/55A	Access Switch/Switch Controller	9825A/SLMS User's Guide (P/N 5952-3222)
432C	Power Meter	AN-196-1 Automated Power Measurements Using the 432C Power Meter Including Waveguide and Fiber Optic Measurements (Note: 432C utilizes the 432C-K01 dedicated interface and no HP-IB)
436A	Microwave Power Meter	AN-401-16 436A Microwave Power Meter/HP 1000 M,E,F Computer (P/N 5953-2815)
42624	Digital LCR Meter	AN-401-14 4262A Digital LCR Meter/HP 1000 M,E,F Computer (P/N 5953-2813)

MODEL NUMBER	DESCRIPTION	DOCUMENT
4943A	Transmission Impairment Measuring Set	Operating Note (shipped w/instrument) (P/N 04943-90026)
4944A	Transmission Impairment Measuring Set	Operating Note (shipped w/instrument) (P/N 04944-90009)
5150A	Thermal Printer	9825A/SLMS User's Guide (P/N 5952-3222)
5312A	Universal Frequency Counter	AN 181-2, Data Acquisition with the 500B
5328A	Universal Frequency Counter	Introductory Operating Guide (for 5328A Universal Counter with 9825A Controller) (P/N 02-5952-7569) Quick Reference Guide for 5328A Universal Counter (P/N 02-5952-7596) Technical Note: 5328A Universal Counter, Programming Via the Hewlett-Packard Interface Bus (P/N 02-5952-7440) AN-287-1 Waveform Analysis using the 5328A Universal Frequency Counter HP-IB Programming Hints for selected instruments, 9825A (P/N 59300-90009)
5335A	Universal Frequency Counter	Introductory Operating Guide (for 5335A Universal Counter with 9835A Controller) (P/N 02-5952-7596)
5340A	Microwave Frequency Counter	Introductory Guide for the 5340A Microwave Counter with the 9825A Controller (02-5952-7556) HP-IB Programming Hints for selected instruments, 9825A (P/N 59300-90005)
5342A	Microwave Frequency Counter	Introductory Operating Guide (for 5342A Microwave Counter with 9825A Controller) (P/N 02-5952-7533) AN-401-4 5342A Microwave Counter/HP 1000 M,E,F Computer (P/N 5953-2803)

MODEL NUMBER	DESCRIPTION	DOCUMENT
5345A/55/56	Frequency Counter	<p>AN-287-2 Frequency Profile using an HP 5345A Electronic Frequency Counter and an HP 5359A Time Synthesizer</p> <p>AN-292-1 Application Guide to the 5355/56 Automatic Frequency Converter</p> <p>Quick Reference Guide for 5345A Electronic Counter (P/N 02-5952-7547)</p> <p>AN-401-3 5345A Counter/HP 1000 M,E,F Computer (P/N 5953-2802)</p> <p>Programming Note: Introductory Programming Guide (for 5345A Electronic Counter with 9825A Controller) (P/N 02-5952-7538)</p>
5345A/44/56	Frequency Counter	<p>Introductory Operating Guide for the 5355A Automatic Frequency Converter with the 9825A Controller (02-5952-7551)</p> <p>HP-IB Programming Hints for selected instruments, 9825A (P/N 59300-90005)</p>
5355A	Automatic Frequency Converter	Introductory Operating Guide for the 5355A Automatic Frequency Converter with the 9825A Controller (02-5952-7551)
5359A	Time Synthesizer	<p>Introductory Operating Guide for the 5359A Time Synthesizer with the 9825A Controller (5952-7565)</p> <p>AN-287-2 Frequency Profile Using an HP 5345A Electronic Frequency Counter and an HP 5359A Time Synthesizer</p> <p>AN-287-3 Frequency Profile Using an HP 5370A Universal Time Interval Counter and an HP 5359A Time Synthesizer</p>
5363B	Time Interval Probes	AN-191-5 Measurement of Propagation delays using the 5370A Time Interval Counter and 5363B Time Interval Probes (Using 9825A)
5370A	Universal Time Interval Counter	<p>Introductory Operating Guide for the 5370A Universal Counter with the 9825A Controller (02-5952-7555)</p> <p>AN-287-3 Frequency Profile using an HP 5370A Universal Time Interval Counter and an HP 5359A Time Synthesizer</p> <p>AN-191-5 Measurement of Propagation delays using the 5370A Time Interval Counter and 5363B Time Interval Probes (using 9825A)</p>



MODEL NUMBER	DESCRIPTION	DOCUMENT
5390A	Frequency Stability Analyzer	AN-225 Measuring Phase Spectral Density of Synthesized Signal Sources Exhibiting $f_0$ and $f_{-1}$ Noise Characteristics with the 5390A Frequency Stability Analyzer  AN-225-1 Measurement Considerations when using the 5390A opt 010
59304A	Numeric Display	HP-IB Programming Hints for selected instruments, 9825A (P/N 59300-90005)
59306A	Universal Switch	HP-IB Programming Hints for selected instruments, 9825A (P/N 59300-9005)  AN-401-18 59306A Relay Actuator/HP 1000 M,E,F Computer (P/N 5953-2817)
59307A	VHF Switch	HP-IB Programming Hints for selected instruments, 9825A (P/N 59300-90005)  AN-401-2 VHF Switch/HP 1000 M,E,F Computer (P/N 5953-2801)
59308A	Timing Generator	HP-IB Programming Hints for selected instruments, 9825A (P/N 59300-90005)
59309A	Digital Clock	HP-IB Programming Hints for selected instruments, 9825A (P/N 59300-90005)  AN-401-8 Digital Clock/HP 1000 M,E,F Computer (P/N 5953-2807)
59310B	HP 1000, M,E,F Interface Card	The HP-IB in HP 1000 Computer Systems User's Manual (P/N 59310-90064)
59403A	Common Carrier Interface	HP-IB Programming Hints for selected instruments, 9825A (P/N 59300-90009)  9825A/SLMS User's Guide (P/N 5952-3222)
59501A	Power Supply Programmer	HP-IB / Power Supply Interface Guide (P/N 5952-3990)  HP-IB Programming Hints for selected instruments, 9825A (P/N 59300-90005)
6002A	Power Supply (option 001)	HP-IB / Power Supply Interface Guide (P/N 5952-3990)  AN-401-9 6002A Power Supply/HP 1000 M,E,F Computer (P/N 5953-2808)

MODEL NUMBER	DESCRIPTION	DOCUMENT
6940B	Multiprogrammer	6940B Multiprogrammer User's Guide for the HP 9825A (P/N 59500-90005)  AN-282-1 6940B Multiprogrammer System Throughput Analysis for Multiprogrammer Systems using the 9825A Desktop Computer (P/N 5952-4017)  14556A Software Library
6942A	Multiprogrammer	6942A Multiprogrammer — Technical Data (5952-4034 D)  Multiprogrammer User's Guide (06942-90003)  AN-401-21 6942A Multiprogrammer II/HP 1000 M,E,F Computer (P/N 5953-2820)
7225A	Plotter	7225/17600 Plotter Demo Tape/9825 (P/N 07225-18002 Rev. A)  7225/17601 Plotter Demo Tape/9825 (P/N 09872-18001 Rev. C)  7225/17601 Plotter Demo Tape/9835 (P/N 09872-18002 Rev. B)  7225/17601 Plotter Demo Tape/9845 (P/N 09872-18003 Rev. B)  7225/17603 Plotter Demo Tape/9845 (P/N 07220-18001 Rev. A)
7245A	Printer/Plotter	7245A/B Plotter/Printer Demo Tape/9825 (P/N 07245-18001 Rev. B)  7245A/B Plotter/Printer Demo Tape/9835/9845 (P/N 07245-18002 Rev. B)
7310A	Graphics Printer	7310A Graphics Printer Demo Tape/9835 (P/N 07310-18002 Rev. A)
8165A	Programmable Signal Source	AN-298 A Stimulus for Automatic Test
8410B	Microwave Network Analyzer	AN-221 Semi-Automatic Measurements Using the 8410B Microwave Network Analyzer and the 9825A
8566A	Microwave Spectrum Analyzer	8566A Spectrum Analyzer Remote Operation (P/N 08566-90003)  85861A Software Pac for 8582A Automatic Spectrum Analyzer (8566A/9825T/HP-IB 9866A), Data Sheet for Software (5952-9352)

MODEL NUMBER	DESCRIPTION	DOCUMENT
8568A	RF Spectrum Analyzer	<p>AN-270-1 An Example of Automatic Measurement of Conducted EMI with the HP 8568A Spectrum Analyzer</p> <p>AN-207-2 Automated Noise Sideband Measurements using the 8568A Spectrum Analyzer "Implementing AN-270-2 with the HP 8568A and HP 9825A" Application Note (5952-9350) Programming Note (5952-9351) Programming Note &amp; Tape (08568-60120)</p> <p>85860A Software Pac for 8581A Automatic Spectrum Analyzer (8568A/9825T/HP-IB/9866B), Data Sheet for Software (5952-9283)</p> <p>8568A Spectrum Analyzer Remote Operating (P/N 08568-90003)</p>
8620C	Sweep Oscillator	<p>AN-187-5 Calculator control of the 8260C using the Hewlett Packard Interface Bus</p> <p>AN-401-17 8620A Sweep Oscillator/HP 1000 M,E,F Computer (P/N 5953-2816)</p>
8660A/B/C	Signal Generator	<p>AN-164-2 Calculator Control of the 8660A/B/C Synthesized Signal Generator (optional HP-IB interface)</p> <p>AN-401-19 8660C Synthesized Signal Generator/HP 1000 M,E,F Computer (P/N 5953-2819)</p>
8662A	Synthesized Signal Generator	AN-283-2 External Frequency Doubling of the 8662A Synthesized Signal Generator
8671A	Microwave Frequency Synthesizer	AN-218-2 Obtaining Millihertz Resolution 8671A & 8672A
8672A	Synthesized Signal Generator	<p>Introductory Operating Guide for the 8672A Synthesized Signal Generator with the 9825A Desktop Computer (5952-8221)</p> <p>AN-401-15 8672A Synthesized Signal Generator/HP 1000 Computer (P/N 5953-2814)</p>
8754A	Network Analyzer	AN-294 Semi-Automatic RF Network Measurements Using the HP 8754A Network Analyzer and the HP 9825A Desktop Computer
8901A	Modulation Analyzer	AN-286-1 Application and Operation of the 8901A Modulation Analyzer

MODEL NUMBER	DESCRIPTION	DOCUMENT
9871A	Printer Plotter	HP-IB Programming Hints for selected instruments, 9825A (P/N 59300-90005) AN-401-20 9871A Character Impact Printer/HP 1000 M,E,F Computer (P/N 5953-2819)
85860	Automatic Spectrum Analyzer (8566A:9825B)	85861-10001 Rev. A Tape 85861-10002 Rev. A Tape (9825T) 85860 Operating & Programming Manual (P/N 85860-90001)
85861	Automatic Spectrum Analyzer (8568A:9825B)	85860-10001 Rev. A Tape 85860-10002 Rev. A Tape (9825T) 85861 Operating & Programming Manual (P/N 85861-90001)
9872A/B/S	Printer Plotter	Four Color Plotter Demo Tape 19825 (P/N 09872-18001 Rev. C)
9872A/B/S	Printer Plotter	Four Color Plotter Demo Tape/9835 (P/N 09872-18002 Rev. B)
9872A/B/C	Printer Plotter	Four Color Plotter Demo Tape/9845 (P/N 09872-18003 Rev. B)



## General HP-IB Bibliography

### HP-IB System Design

AUTHOR'S NAME	DESCRIPTION
1	"American National Standard for the representation of numeric values in character strings for information interchange," ANSI X3.42-1975, American National Standards Institute, 1430 Broadway, New York, NY 10018.
2	Application Bulletin AB-25 "System use of the Fluke Model 8500A," J. Fluke Mfg. Co., Inc. 1976.
3 Baunach, S.C.	"An Example of an M6800-Based GPIB Interface" Tektronix, Inc. 1977.
4 Bossart, R. K.	Electromagnetic Interference Testing . . . standards and specs, Electronics Test, May 1980, pp. 76-83.
5 A. Capell, D. Knoblock, L. Mather and L. Lopp	"Process refinements bring C-MOS on sapphire into commercial use," Electronics, pp. 99-107, May 26, 1977.
6 Capps, Charles	Phase Match Cables With Automated Testing, Microwaves, January 1979, pp. 6271.
7 Carlson, Alan W.	Many Choices Face Designer, Microwave Systems News, December 1978, pp. 40-48, 95.
8 Coates, T.	"Interfacing to the interface: Practical considerations beyond the scope of IEEE Standard 488," presented at WESCON 75 Conf., Session 3, Sept. 1975.
9 Evans, J. and Merrill, H.	"A standard interface applied to measurement systems," in ISA Proc. 22nd Int. Instrument Symp., Vol. 3, pp. 17-28, 1976.
10 Fisher, P. D. and Welch, S. M.	"Part Two: How to build an automated system around a programmable calculator," Electronics, pp. 104-109, May 16, 1974.
11 Fluke, J. M., Jr.	"System considerations in using the IEEE Digital Instrument Bus," presented at WESCON 75 Conf., Session 3, Sept. 1975.  "A practical approach to automating test stations," Instrum. Control Syst., pp. 17-21, July 1976.
12 Freytag, H. H. and ten-Thiede, A. K.	"Konzeption Programmierbarer MeBgerate mit IEC-Standard-Interface," Frequenz, pp. 190-195, July 30, 1976.

AUTHOR'S NAME	DESCRIPTION
13 Geismann, James H.	IEEE-488: Where will the Bus Stop Next?, 1979 Wescon Professional Program Session 19, Papers 19/0 thru 19/4. September 1979.
14 Ghannam, Adel N., Fayez, Mona M.	"Unified Approach to and Designing Hardware Based on the IEEE STDF 488," Computer Design, September 1979, pp. 105-110
15 Gilder, J. H.	"Microprocessors are making the 'impossible' possible," Electronic Design, pp. 25-55, Nov. 22, 1975.
16 Gur, Mete	"An Evaluation of the IEC/IEEE Interface Bus," Electronics Engineering, September 1978.
17 Henckels, Lutz; Haas, Rene; Lo, Chi-yuan	Hierarchical and Concurrent Fault Simulation, Electronic Test, March 1980, pp. 54-58.
18 Herbert, V.	"Pollution monitoring doesn't have to be costly," Instrum. Control Syst., pp. 27-30, Apr. 1976.
19 Hewlett-Packard Interface Bus User's Guide, 9830A, 1974.	
20 IEEE Recommended Practice for Code and Format Conventions, Draft document under development (P728).	
21 IEEE Standard 488-1978, "Digital interface for programmable instrumentation," The IEEE, Inc., 345 East 47th St., New York, NY, Nov. 1978.	
22 "Instrument communications: A new interface system" presented in INTERCON 73 Conf., Mar. 1973.	
23 Klaus, J.	"Wie Funktioniert der IEC-Bus?" Elektronik, heft 4, pp. 72-78, and heft 5, pp. 73-78, 1975.
24 Klein, P. E. and Wilhelmy, H. J.	"Der IEC-BUS," Elektronik, Vol. 10, pp. 63-74, October 1977.
25 Knoblock, D. E.	"Identifying, understanding, and selecting among the capabilities provided by IEEE Standard 488," presented at WESCON 75 Conf., Session 3, Sept. 1975.
26 Knoblock, D. E. Loughry, D. C. and Vissers, C. A.	"Insight into interfacing," IEEE Spectrum pp. 50-57, May 1975.
27 Kuhn, Nick	Home-Built Mini-Systems Become Commonplace, Microwave Systems News, December 1978, pp. 51-58.
28 Kuhn, Nick	Noise-Figure Test Setup Provides High Accuracy, Microwaves, November 1979, pp. 73-76.

AUTHOR'S NAME	DESCRIPTION
29 Lane, Richard Q.	Derive Noise and Gain Parameters in 10 Seconds, <i>Microwaves</i> , August 1978, pp. 53-57.
30 Lange, A.	"OPTACON R interface permits the blind to 'read' Digital Instruments," <i>EDN</i> , pp. 84-86, Feb. 5, 1976.
31 Lee, R. C.	Microprocessor Implementation of a Measurement Instrument and Its Interface," <i>WESCON 75 Conference</i> , Session 3, Sept. 1975.
32 Loughry, D. C.	"Digital bus simplifies instrument system communication," <i>EDN Mag.</i> pp. 22-28, Sept. 1972.
33 Loughry, D. C.	"A common digital interface for programmable instruments: The evolution of a system," <i>Hewlett-Packard Journal</i> , pp. 8-11, Oct. 1972.
34 Loughry, D. C.	"What makes a good interface?" <i>IEEE Spectrum</i> , pp. 52-57, Nov. 1974.
35 Loughry, D. C.	Don Loughry on the ANSI/IEEE standard 488 and the HP Interface Bus, <i>Hewlett Packard Journal</i> , December 1979, pp. 27-28.
36 Loughry, D. C.	IEEE Standard 488 and Microprocessor Synergism, <i>Proceedings of the IEEE</i> , Vol. 66, No. 2, February 1978, pp. 162-172.
37 Marshall, M.	"Intelligent instruments - They expand measurement capabilities, yet simplify the task," <i>EDN Magazine</i> , pp. 54-65, Apr. 20, 1977.
38 McNamee, Mike	Automate For Improved Phase-Noise Measurement, <i>Microwaves</i> , May 1979, pp. 80-85.
39 Megill, Norman D.	Test Fixture Noise, <i>Electronics Test</i> , May 1980, pp. 46-54.
40 Menne, Don	Instruments '80: Brainer on-site troubleshooting tools dig out component-level faults, <i>Electronic Design</i> , October 21, 1979, pp. 74-79.
41 Moncrief, Frank	Boost productivity and slash errors with computer-controlled measurements, <i>Microwaves</i> , January 1979, pp. 50-61.
42 Mueche, C. E. and Lin, C. S.	"IEEE 488 applied to radar and scientific systems," presented at <i>ELECTRO 76 Conference</i> , Session 29, May 1976.
43 Mukaihata, Tadao and Johnstone, Richard D.	Implementation and Use of Small Automated-Test Systems, <i>Proceedings of the IEEE</i> , Vol. 66, No 4, April 1978, pp. 403-413.

AUTHOR'S NAME	DESCRIPTION
44 Myles, R.	"IEC interface: A microprocessor based implementation," presented in IMEKO VII Cong., London, England, Vol. 3, May 1976.
45 Nelson, J. E.	"Exploding technology is shaping the course of tomorrow's instrumentation," <i>Instrum. Control Syst.</i> , pp. 43-46, June 1976.
46 Nelson, J. E. and Ricci, D. W.	"A practical interface system for electronic instruments," <i>Hewlett Packard J.</i> , pp. 2-7, Oct. 1972.
47 Pannach, A.	"Interface-entwicklung fur den IEC Bus," <i>Elektronik</i> , heft 2, pp. 61-64, Dec. 1975.
48 Philips, N. V.	Test and Measuring Department Digital Instrument course Part 4, IEC Bus Interface, Eindhoven, The Netherlands. Publication number 9498.829.99311.
49 Rhine, G.	"IEEE 488 applied to a graphic terminal," presented at ELECTRO 76 Conf., Session 29, 1976.
50 Ronnenburg, Charles H. and Trapp, Robert L.	Automated Antenna Tests Save Time and Cut Costs, <i>Microwaves</i> , January 1980, pp. 66-72.
51 Ricci, David	IEEE 488: Its Impact on the Design, Building, and Automatic Test and Measurement Systems, WESCON Paper, May 1980.
52 Ricci, D. W. and Stone, P. S.	"Putting together instrumentation systems at minimum cost," <i>Hewlett Packard J.</i> , pp. 5-11, Jan. 1975.
53 Ricci, D. W. and Nelson, G. E.	"Standard instrument interface simplifies system design," <i>Electronics</i> , pp. 95-106, Nov. 14, 1974.
54 Richert, U.	"IEC-Bus Interface fur prozebrochner," <i>Elektronik</i> , heft 12, pp. 58-62, 1976.
55 Richter, M.	"Das Zustandediagramm und seine Anwendung beim IEC-Bus," <i>Elektronik</i> , heft 2, pp. 55-58, Feb. 1977.
56 Runyan, Stan	Instruments' 80: Probing the high SQ world of measurements. <i>Electronics Design</i> , October 11, 1979, pp. 68-69.
57 Santon, Andy	"IEEE-488 Compatible Instruments," <i>EDN</i> , November 5, 1979, pp. 91-98.
58 Sideris, George	Instruments' 80: Compatible-instrument clusters promise speedier, smarter bench measurements, <i>Electronics Design</i> , October 11, 1979, pp. 85-89.



AUTHOR'S NAME	DESCRIPTION
59 Schindler, Max	Instruments' 80: BASIC Underlies Multiple Languages of Smart Instruments, <i>Electronic Design</i> , October 21, 1979, pp. 94-98.
60 Smith, Leon	Join 488-bus Instruments and Efficient Software for fast, automatic tests, <i>Electronic Design</i> 24, November 22, 1979, pp. 142-148.
61 Smyth, David	Let your personal computer talk to test equipment, <i>Electronic Design News</i> , August 20, 1979, pp. 118-122.
62 Stanley, George C.	"The Impact of the IEEE-488 Concept on Measurement Productivity," <i>ISA Transactions</i> , Vol. 21, Number 4, pp. 9-13.
63 Sugarman, R.	"IEEE interface beats microprocessor as most-wanted signal generator feature," <i>Electronic Eng. Times</i> , p. 18, Feb. 16, 1976.
64 Summers, J.	"IEC Interface Bus (IEEE-488) Simplified," <i>Electronics Engineering</i> , December 1979, pp. 45-55.
65 Tolliver, Mark	Directions in Automatic Test and Measurement Systems, <i>ISA Paper</i> , October 25, 1979.
66 Trifari, J.	"Micros boost test-gear power," <i>Electronic Products Magazine</i> , pp. 35-39, Oct. 1976.
67 Twaddell, William	"Low-cost, high capability LSI chips ease interface-bus implementation," <i>EDN</i> , November 5, 1979, pp. 36-40.
68 USA Standard Code for Information Interchange, ANSI X3.4-1977, American National Standards Institute, 1430 Broadway, New York, NY 10018.	
69 Vissers, C. A.	"Interface a dispersed architecture," presented in 3rd. Annu. Symp. Computer Architecture, Clearwater, Florida, Jan. 1976.
70 Wiedwald, J. and West, B.	"Recent advances in microprocessor-based test and measuring equipment," presented at WESCON 76 Conf., Session 24, 1976.
71 Witmer, Frank	In-Circuit Resistance Measurements, <i>Electronics Test</i> , December 1979, pp. 32-34.
72 Yencharis, L.	"Expansion of IEEE interface to automatic test equipment cited as main improvements; Microprocessor still not a major addition," <i>Electronic Eng. Times</i> , pp. 16-19, June 27, 1977.
73 Young, Richard	"Implementing an IEEE-488 Bus Controller with Microprocessor Software," <i>IEEE Transactions on Industrial Electronics and Control Instrumentation</i> . Vol. IECI-27, No. 1, Feb. 1980, pp. 10-15

## Hewlett-Packard HP-IB Verification Programs

These are documented verification programs for many Hewlett-Packard instruments. Contact your local HP office for more details.

	MODEL	TAPE PART NO.	PROGRAM DOCUMENTATION
3042A	Network Analyzer	03042-90211 (9825A)	3042A Manual
3045A	Spectrum Analyzer	03045-10001 (9825A)	3045A Manual
3047A	Spectrum Analyzer with 35601A Interface	35601-10001 (9845B) 35601-10011 (9836A)	35601A Manual 35601A Manual
3050B	Voltmeter System	03050-90230 (9825A2) 03050-90212 (9830A)	3050B Manual 3050B Manual
3052A	Voltmeter System	03052-90011 (9825A) 03052-10002 (9835A) 03052-10004 (9835B) 03052-10008 (9845B)	3052A Manual 3052A Manual 3052A Manual 3052A Manual
3054A	Voltmeter System	03054-10002 (9835A) 03054-10005 (9845B)	3054A Manual 3054A Manual
3335A	Frequency Synthesizer	03335-10001 (9825A)	3335A Manual
3437A	System DVM	03437-10001 (9825A)	3052A Manual
3455A	System DVM	03455-10001 (9830A) 03455-10002 (9825A)	3052A Manual 3052A Manual
3495A	Scanner	03495-10001 (9830A) 03495-10002 (9825A)	3495A Manual 3495A Manual
3582A	Spectrum Analyzer	03582-10001 (9825A)	3582 Manual
3585A	Spectrum Analyzer	03585-10001 (9825A)	3585 Manual
37201A	HP-IB Extender	37201-18100 (9825A)	37201A Manual
37203A	HP-IB Extender	37203-12101 (9825A)	37203A Manual
3745A	Sel. Level Meas. Set	03745-18003 (9825A)	3745A/B-52 Serv Note
3745B	Sel. Level Meas. Set	03745-18003 (9825A)	3745A/B-52 Serv Note
3747A	Sel. Level Meas. Set	03745-18003 (9825A)	3747A/B-23 Serv Note
3747B	Sel. Level Meas. Set	03745-18003 (9825A)	3747A/B-23 Serv Note
3746A	Sel. Level Meas. Set	program in manual	3746A Manual
3755A	Switch Controller	program in manual	3755A Manual
3771A	Data Line Analyzer	program in manual	3771A Manual
3771B	Data Line Analyzer	program in manual	3771B Manual
3777A	Channel Selector	program in manual	3777A Manual
3779A	Pri. Multiplex Analyzer	program in manual	3779A Manual
3779B	Pri. Multiplex Analyzer	program in manual	3779B Manual
3785A/B	Jitter Generator/Receiver	03785-10004 (85A)	3785A/B Manual
4192A	LF Impedance Analyzer	04192-90501 (9825B)	04192-90100 Op. Note
436A	Power Meter	00436-10006 (9830A) 00436-10007 (9825A)	436A Manual 436A-2 Serv Note
5005B	Signature Multimeter	59300-10002 (85A)	5005B Manual
5150A	Thermal Printer	59300-10001 (9825A)	5050A-4 Serv Note

	MODEL	TAPE PART NO.	PROGRAM DOCUMENTATION
5312A	ASCII Interface (5300B)	59300-10001 (9825A)	5312A-2 Serv Note
5312A	HP-IB Interface Module	59300-10002 (85A)	5312A-4A Serv Note
5316A	Universal Cntr.	59300-10002 (85A)	5316A-3A Serv Note
5328A	Universal Cntr.(Opts.011, 020,021,030,031,040,041)	59300-10001 (9825A)	5328A-17 Serv Note
5328A	Universal Cntr.(Opt.H99)	59300-10001 (9825A)	5328A/H99 Manual
5328A	Universal Cntr. (Opt.096/H42)	59300-10001 (9825A)	5328A/H42 Manual
5328A	Universal Cntr.(Opts.011, 020,021,030,031,040,041)	59300-10002 (85A)	5328A-33B Serv Note
5328A	Universal Cntr.(military)	59300-10002 (85A)	5328A-34B Serv Note
5335A	Universal Cntr.	59300-10001 (9825A) 59300-10002 (85A)	5335A Manual 5335A-7B Serv Note
5340A	Frequency Cntr.(Opt.011)	59300-10001 (9825A)	5340A-11 Serv Note
5341A	Frequency Cntr.(Opt.011)	59300-10001 (9825A)	5341A Manual
5342A	Microwave Cntr.(Opt.011)	59300-10001 (9825A)	5342A Manual
5342A	Microwave Cntr.(Opts.002,011)	59300-10002 (85A)	5342A-32A Serv Note
5343A	Microwave Cntr.(Opt.011)	59300-10001 (9825A)	5343A Manual
5343A	Microwave Cntr.(Opts.004,011)	59300-10002 (85A)	5343A-11A Serv Note
5344S	Microwave Source Synchro.	59300-10002 (85A)	5344S Manual
5345A	Electronic Cntr.(Opt.011)	59300-10001 (9825A)	5345A-9A Serv Note
5345A	Electronic Cntr.(Opt.012)	59300-10001 (9825A)	5345A-12A Serv Note
5345A	Electronic Cntr.(Opt.011)	59300-10002 (85A)	5345A-19A Serv Note
5345A	Electronic Cntr.(Opt.012)	59300-10002 (85A)	5345A-20A Serv Note
5353A	Channel C Plug-In	59300-10001 (9825A)	5353A-1 Serv Note
5354A	4 GHz Frequency Cntr.	59300-10001 (9825A)	5354A-6 Serv Note
5355A	Automatic Frequency Cnvr.	59300-10001 (9825A)	5355A Manual
5358A	Measurement Stor. Plug-In	59300-10001 (9825A)	5358A Manual
5359A	Time Synthesizer	59300-10001 (9825A)	5359A Manual
5363A	Time Interval Probes	59300-10001 (9825A)	5363A-2 Serv Note
5363B	Time Interval Probes	59300-10001 (9825A)	5363B Manual
5370A	Univ. Time Intv. Cntr.	59300-10001 (9825A)	5370A-1A Serv Note
5420A/B	Digital Signal Analyzer	05420-69002 (9825A/B)	Supplied with tape
5423A	Structural Dynamics Ana.	05420-69002 (9825A/B)	Supplied with tape
59301A	ASCII/Parallel Cnvr.	59300-10001 (9825A)	59301-2 Serv Note
59303A	Digital-to-Analog Cnvr.	59300-10001 (9825A)	59303A-1 Serv Note
59304A	Numeric Display	59300-10001 (9825A)	59304A-1 Serv Note
59306A	Relay Actuator	59300-10001 (9825A)	59306A-4 Serv Note
59307A	VHF Switch	59300-10001 (9825A)	59307A-3 Serv Note
59308A	Timing Generator	59300-10001 (9825A)	59308A-1 Serv Note
59309A	Digital Clock	59300-10001 (9825A)	59309A-3 Serv Note
59313A	Analog-to-Digital Cnvr.	59300-10001 (9825A)	59313A Manual
59500A	Multiprogmr. Interface	14551-13001 (9825A)	Supplied with tape
6034A	Power Supply	06034-10002 (85A)	06034-10002 Kit Manual
69321B	D/A Voltage Converter	14551-13001 (9825A)	Supplied with tape
6940B	Multiprogmr.	14551-13001 (9825A)	Supplied with tape
6941B	Multiprogmr. Extndr.	14551-13001 (9825A)	Supplied with tape

	MODEL	TAPE PART NO.	PROGRAM DOCUMENTATION
6942A	Multiprogrmr.	14710-13001 (9825A)	Supplied in classroom
69xxx	Multiprogrmr. Plug-In Cds.	14551-13001 (9825A)	Supplied with tape
7220	Graphics Plotter	07220-18001 (9825A)	Supplied with tape
		5010-2585 (85A)	Supplied with tape
		(order from CPC)	
		5957-3862 (85A)	Supplied with tape
		(order from SDD)	
7221	Graphics Plotter	07221-18010 (264x)	Supplied with tape
		5010-2585 (85A)	Supplied with tape
		(order from CPC)	
		5957-3862 (85A)	Supplied with tape
		(order from SDD)	
7225	Graphics Plotter with 17600 Module	07225-18002 (9825A)	Supplied with tape
		07225-18003 (9815)	Supplied with tape
		5010-2585 (85A)	Supplied with tape
		(order from CPC)	
		5957-3862 (85A)	Supplied with tape
		(order from SDD)	
7225	Graphics Plotter with 17601 Module	09872-18001 (9825A)	Supplied with tape
		09872-18002 (9835A)	Supplied with tape
		09872-18003 (9845B)	Supplied with tape
		5010-2585 (85A)	Supplied with tape
		(order from CPC)	
		5957-3862 (85A)	Supplied with tape
		(order from SDD)	
7225	Graphics Plotter with 17603 Module	07220-18001 (9825A)	Supplied with tape
		5010-2585 (85A)	Supplied with tape
		(order from CPC)	
		5957-3862 (85A)	Supplied with tape
		(order from SDD)	
7245	Plotter/Printer	07245-18001 (9825A)	Supplied with tape
		07245-18002 (9835/45)	Supplied with tape
7310	Graphics Printer	07310-18001 (2647)	Supplied with tape
		07310-18002 (9835)	Supplied with tape
7470	Graphics Plotter	5010-2585 (85A)	Supplied with tape
		(order from CPC)	
		5957-3862 (85A)	Supplied with tape
		(order from SDD)	
7580	Drafting Plotter	5010-2585 (85A)	Supplied with tape
		(order from CPC)	
		5957-3862 (85A)	Supplied with tape
		(order from SDD)	
7585	Drafting Plotter	5010-2585 (85A)	Supplied with tape
		(order from CPC)	
		5957-3862 (85A)	Supplied with tape
		(order from SDD)	
8160A	Programmable Pulse Gen.	08160-39910 (9825A)	Supplied with tape
8409B	Network Analyzer	11863-10004 (9835/45)	8409B, 11863D Manual
8409C	Network Analyzer	11863-10006 (9845B)	8409C, 11863F Manual
8409D	Network Analyzer	11863-10005 (9826B)	8409C, 11863E Manual

	MODEL	TAPE PART NO.	PROGRAM DOCUMENTATION
8501A	Storage Normalizer	Contact HP for tape	8501A Manual
8507A	Network Analyzer	85030-10002 (9830A)	8507A Manual
8507B	Network Analyzer	85030-10007 (9825A)	8507B Manual
8507C	Network Analyzer	85030-10013 (9845B)	8507C Manual
8566A	Spectrum Analyzer	08566-60002 (9825B) 08566-90005 (9825B)	8566A Manual Manual only
8568A	Spectrum Analyzer	08568-60002 (9825B) 08568-90028 (9825B)	8568A Manual Manual only
8620C	Sweeper Mainframe	Contact HP for tape	Supplied with tape
86210	Sweeper Plug-in	Contact HP for tape	Supplied with tape
86220	Sweeper Plug-in	Contact HP for tape	Supplied with tape
86222	Sweeper Plug-in	Contact HP for tape	Supplied with tape
86230	Sweeper Plug-in	Contact HP for tape	Supplied with tape
86235	Sweeper Plug-in	Contact HP for tape	Supplied with tape
86241	Sweeper Plug-in	Contact HP for tape	Supplied with tape
86242	Sweeper Plug-in	Contact HP for tape	Supplied with tape
86245	Sweeper Plug-in	Contact HP for tape	Supplied with tape
86250	Sweeper Plug-in	Contact HP for tape	Supplied with tape
86260	Sweeper Plug-in	Contact HP for TAPE	Supplied with tape
86290	Sweeper Plug-in	Contact HP for tape	Supplied with tape
86320	Sweeper Plug-in	Contact HP for tape	Supplied with tape
86330	Sweeper Plug-in	Contact HP for tape	Supplied with tape
86331	Sweeper Plug-in	Contact HP for tape	Supplied with tape
86341	Sweeper Plug-in	Contact HP for tape	Supplied with tape
86342	Sweeper Plug-in	Contact HP for tape	Supplied with tape
86350	Sweeper Plug-in	Contact HP for tape	Supplied with tape
86351	Sweeper Plug-in	Contact HP for tape	Supplied with tape
86352	Sweeper Plug-in	Contact HP for tape	Supplied with tape
8660A/C	Synthesized Sig. Gen.	08660-10001 (9825A)	8660A-29 Serv Note
8662A	Synthesized Sig. Gen.	08662-60310 (9825A)	08662-60057 Op. Note
8672A	Synthesized Sig. Gen.	11712-10001 (9830A) 11712-10002 (9825A)	11712-90001 Kit Manual 11712-90001 Kit Manual
9872	Graphics Plotter	09872-18001 (9825A) 09872-18002 (9835A) 09872-18003 (9845B) 5010-2585 (85A) (order from CPC) 5957-3862 (85A) (order from SDD)	Supplied with tape Supplied with tape  Supplied with tape  Supplied with tape

## Appendix A

### Interface Capability Codes for Hewlett-Packard Products

More and more frequently data sheets and instruments are listing their interface capabilities. On an instrument this often shows up near the HP-IB connector as is illustrated below:

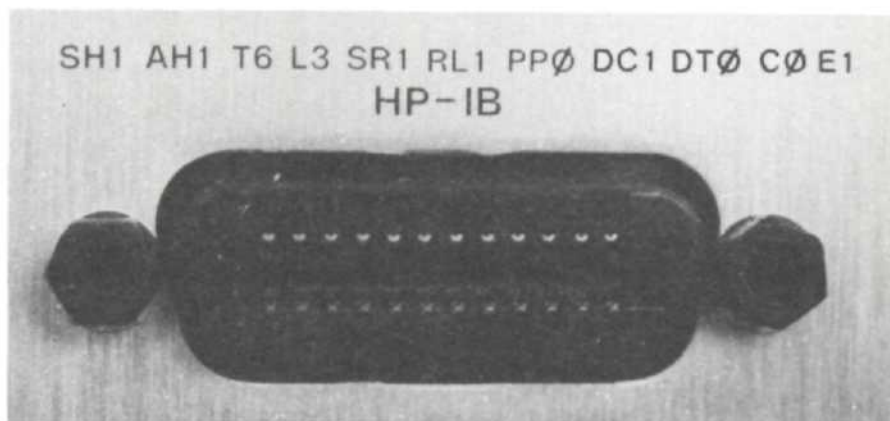

Rear Panel of HP-IB Instrument Showing Interface Capability Codes

Understanding these symbols is especially useful to the system's engineer as they completely describe the products' interface capability. IEEE standard 488-1978 describes these functions in detail.

#### Interface Functions

1.	SOURCE HANDSHAKE	SH
2.	ACCEPTOR HANDSHAKE	AH
3.	TALKER (EXTENDED TALKER)	T(TE)
4.	LISTENER (EXTENDED LISTENER)	L(LE)
5.	SERVICE REQUEST	SR
6.	REMOTE LOCAL	RL
7.	PARALLEL POLL	PP
8.	DEVICE CLEAR	DC
9.	DEVICE TRIGGER	DT
10.	CONTROLLER	C
11.	DRIVER ELECTRONICS	E

#### Source Handshake (SH)

SH0 NO CAPABILITY  
SH1 FULL CAPABILITY

#### Acceptor Handshake (AH)

AH0 NO CAPABILITY  
AH1 FULL CAPABILITY

Talker (T)	Extended Talker (TE)			
	Basic Talker	Serial Poll	Talk Only Mode	Unaddresses if MLA
T0	NO	NO	NO	NO
T1	YES	YES	YES	NO
T2	YES	YES	NO	NO
T3	YES	NO	YES	NO
T4	YES	NO	NO	NO
T5	YES	YES	YES	YES
T6	YES	YES	NO	YES
T7	YES	NO	YES	YES
T8	YES	NO	NO	YES

Listener (L)	Extended Listener (LE)		
	Basic Listener	Listen Only Mode	Unaddressed if MTA
L0	NO	NO	NO
L1	YES	YES	NO
L2	YES	NO	NO
L3	YES	YES	YES
L4	YES	NO	YES

### Service Request (SR)

SR0 NO CAPABILITY  
SR1 FULL CAPABILITY

### Remote Local (RL)

RL0 NO CAPABILITY  
RL1 COMPLETE CAPABILITY  
RL2 NO LOCAL LOCKOUT

### Parallel Poll (PP)

PP0 NO CAPABILITY  
PP1 REMOTE CONFIGURATION  
PP2 LOCAL CONFIGURATION

### Device Clear (DC)

DC0 NO CAPABILITY  
DC1 FULL CAPABILITY  
DC2 OMIT SELECTIVE DEVICE CLEAR

### Device Trigger (DT)

DT0 NO CAPABILITY  
DT1 FULL CAPABILITY

### Driver Electronics

E1 OPEN COLLECTOR (250KB/SEC MAX)  
E2 TRI STATE (1MB/SEC MAX)

### Controller (C)

These are 29 controller levels. The more significant are:

C0 NO CAPABILITY	C5 SEND INTERFACE MESSAGES, RECEIVE CONTROL, PASS CONTROL TO SELF, PARALLEL POLL, TAKE CONTROL SYNCHRONOUSLY
C1 SYSTEM CONTROLLER	
C2 SEND IFC AND TAKE CHARGE	
C3 SEND REN	
C4 RESPOND TO SRQ	

The following is a list of interface capabilities for HP instruments as of spring 1981.

PRODUCT RELATED TO:

**Stimulus**

Model #	Interface Functions												
8170A	SH1	AH1	L4	T5	SR1	RL1	PP0	DC0	DT0	C0			
8165A	SH1	AH1	L4	T6	SR1	RL1	PP0	DC0	DT1	C0			
8161A	SH1	AH1	L4	T6	SR1	RL1	PP0	DC0	DT1	C0			
8160A	SH1	AH1	L4	T6	SR1	RL1	PP0	DC0	DT1	C0			
8018A	SH0	AH1	L2	T0	SR0	RL1	PP0	DC1	DT1	C0	Opt	001	
8016A	SH0	AH1	L2	T0	SR0	RL1	PP0	DC0	DT1	C0	Opt	001	
3325A	SH1	AH1	T6	L3	SR1	RL1	PP0	DC1	DT0	C0	E1		
8350A	SH1	AH1	T6	L4	SR1	RL1	PP0	DC1	DT1	C0	E1		
8620C	SH0	AH1	T0	L2	SR0	RL2	PP0	DC0	DT0	C0	E1		
6002A	AH1	L2									Opt	001	
5359A	SH1	AH1	T2	L2	SR1	RL1	PP0	DC1	DT1	C0	E1		
8672A/ 8671A		DC1	RL2	SR1	PP2	T6	L4	AH2	SH1	DT0	C0		
8660A/C	SH0	AH1	T0	L2	SR0	RL1	PP0	DC2	DT0	C0			
8662A	SH1	AH1	T6	TE0	L3	LE0	SR1	RL1	PP0	DC1	DT1	C0	
8656A	SH1	AH1	T0	L2	SR0	RL1	PP0	DC1	DT0	C0			
4140B	SH1	AH1	T5	L4	SR1	RL1	DC1	DT1	Std				

**Measurement**

1980A	SH1	AH1	T5	TE0	L3	LE0	SR1	RL1	PP0	DC0	DT1	C0	E2	
4943A	SH1	AH1	T6	L4	SR1	RL2	PP0	DC2	DT0	C0	E1			
4944A	SH1	AH1	T6	L4	SR1	RL2	PP0	DC2	DT0	C0	E1			
2804A	SH1	AH1	T1	L1	SR1	RL1	PP1	DC1	DT1	C0	E2			
1615A	SH1	AH1	T5	L4	SR1	RL1	PP0	DC0	DT0	C0	E1	Opt	001	
1610A/B	SH1	AH1	T1	TE0	L1	LE0	SR1	RL1	PP0	DC1	DT0	C0	Opt	003
1602A	SH1	AH1	T7	TE0	L4	LE0	SR0	RL1	PP0	DC0	DT0	C0	Opt	001
3455A	SH1	AH1	T5	L4	SR1	RL1	PP0	DC1	DT1	C0	E1			
3437A	SH1	AH1	T5	L4	SR1	RL1	PP0	DC1	DT1	C0	E1			
3490A	SH1	AH1	T5	L4	SR1	RL2	PP0	DC0	DT1	C0	E1			
3456A	SH1	AH1	T5	L4	SR1	RL1	PP0	DC1	DT1	C0	E1			
3438A	SH1	AH0	T3	L0	SR0	RL1	PP0	DC0	DT1	C0				
3582A	SH1	AH1	T6	L4	SR1	RL1	PP0	DC1	DT0	C0				
3585A	SH1	AH1	T6	L4	SR1	RL1	PP0	DC1	DT1	C0				
3586ABC	SH1	AH1	T6	TE0	L4	LE0	SR1	RL1	PP0	DC1	DT1	C1	C3	C28
8501A	SH1	AH1	T6	L4	SR1	RL1	PP0	DC1	DT0	C0	E1			
8503A	SH1	AH1	T8	L4	SR0	RL2	PP0	DC0	DT0	C0	E1			
8503B	SH1	AH1	T8	L4	SR0	RL2	PP0	DC0	DT0	C0	E1			
8505A	SH1	AH1	T8	L4	SR0	RL1	PP0	DC0	DT0	C0	E1			
5353A	SH0	AH1	T0	L2	SR0	RL1	PP0	DC0	DT0	C0	E2	Opt	011	
5354A	SH0	AH1	T0	L2	SR0	RL1	PP0	DC0	DT0	C0	E2	Opt	011	
5355A	SH0	AH1	T0	L2	SR0	RL1	RR0	DC1	DT1	C0	E1			
5342A	SH1	AH1	T1	L2	SR1	RL1	PP0	DC1	DT1	C0	E1	Opt	011	
5343A	SH1	AH1	T1	L2	SR1	RL1	PP0	DC1	DT1	C0	E1	Opt	011	
5335A	SH1	AH1	T1	L2	SR1	RL1	PP0	DC1	DT1	C0	E1			
5328A	SH1	AH1	T1	L2	SR1	RL1	PP0	DC1	DT1	C0	E1	Opt	011	
5312A	SH1	AH1	T3	L2	SR0	RL0	PP0	DC0	DT1	C0	E1			
5316A	SH1	AH1	T1	L2	SR1	RL1	PP0	DC1	DT1	C0	E1	Std	001	
5345A	SH1	AH1	T3	L2	SR1	RL2	PP0	DC0		DT0	C0	E2	Opt	011



**Measurement**

5345A	SH1	AH1	T1	L2	SR1	RL1	PP0	DC1	DT1	C0	E2	Opt	012		
5370A	SH1	AH1	T1	L2	SR1	RL1	PP0	DC1	DT1	C0	E1				
5340A	SH1	AH1	T3	L2	SR1	RL2	PP0	DC1	DT0	C0	E1	Opt	011		
5363A	SH1	AH1	T0	L2	SR1	RL1	PP0	DC0	DT0	C0	E1				
8566A	SH1	AH1	T6	L4	SR1	RL1	PP0	DC1	DT1	C0	E1	Std			
8568A	SH1	AH1	T6	L4	SR1	RL1	PP0	DC1	DT1	C0	E1	Std			
3717A	SH0	AH1	T0	TE0	L2	LE0	SR0	RL2	PP0	DC1	DT0	C0	Opt	100	
3724A	SH1	AH1	T5	L4	SR1	RL1	PP0	DT0	L0	DC1					
3725B	SH1	AH1	T5	L4	SR1	RL1	PP0	DT0	L0	DC1					
3726C	SH1	AH1	T5	L4	SR1	RL1	PP0	DT0	L0	DC1					
3745A/B	C1	C2	C3	C28	SH1	T3	TE0	AH0	L0	LE0	SR0	RL0	DC0	PP0	
DT0 Manual Remote															
3747A	C0	AH1	L4	LE0	SH1	T6	TE0	SR1	RLN2		DC1	PP0	DT0		
3771A/B	SH1	AH1	T1	TE0	L2	LE0	SR1	RL2	PP0	DC1	DT0	C0	Opt	005	
3777A	SH0	AH1	T0	L2	SR0	RL0	PP0	DC0	DT0	C0					
3779A/B	SH1	AH1	T6	TE0	L4	LE0	SR1	RL1	PP0	DC1	DT0	C1	C2	C3	C11
3781B	SH1	AH1	T6	TE0	L4	SR1	RL1	PP0	DC1	DT0	C0				
3782B	SH1	AH1	T5	TE0	L4	LE0	SR1	RL1	PP0	DC1	DT0	C0			
436A	AH1	C0	DC2	DT0	LE0	PP0	RL2	SH1	SR0	T3	TE0				
8901A	SH1	AH1	T5	TE0	L3	LE0	SR1	RL1	PP0	DC1	DT1	C0			
8903A	SH1	AH1	T5	TE0	L3	LE0	SR1	RL1	PP0	DC1	DT1	C0			
4191A	SH1	AH1	T5	L4	SR1	RL1	DC1	DT1	Std						
4192A	SH1	AH1	T5	L4	SR1	RL1	DC1	DT1	E1						
4262A	SH1	AH1	T5	L4	SR1	RL1	DC1	DT1	Opt	101					
4274A	SH1	AH1	T5	L4	SR1	RL1	DC1	DT1	Opt	101					
4275A	SH1	AH1	T5	L4	SR1	RL2	DC1	DT1	Opt	101					

**Switching Scanning Translation or Timing**

3497A	SH1	AH1	T5	L4	SR1	RL1	PP0	DC1	DT1	C0	E1				
3495A	SH0	AH1	T0	TE0	L2	LE0	SR0	RL0	PP0	DC1	DT1	C0	E1		
59403A	SH1	AH1	T2	L2	TE0	LE0	SR1	RL0	PP0	DC0	DT0	DT0	C2	E1	
59500A	SH1	AH1	T6	L4	SR1	RL0	PP0	DC0	DT0	C0					
6942A	SH1	AH1	T1	SR1	PP1	TE4	DC1	DT0	C0						
59501A	AH1	L2													
59308A	SH1	AH1	T2	L2	SR1	RL1	PP0	DC0	DT0	C0	E1				
59313A	SH0	AH1	T2	L2	SR1	RL0	PP1	DC0	DT0	C0	E1				
59301A	SH0	AH1	T0	L1	SR0	RL0	PP0	DC0	DT0	C0	E1	Std			
59303A	SH0	AH1	T0	L2	SR0	RL1	PP0	DC1	DT0	C0	E1	Std			
59306A	SH0	AH1	T0	L2	SR0	RL1	PP0	DC0	DT0	C0	E1	Std			
59307A	SH0	AH1	T0	L2	SR0	RL1	PP0	DC0	DT0	C0	E1	Std			

**Design and Servicing**

59401A	SH1	AH1	T1	TE0	L1	LE0	SR1	RL0	PP0	DC0	DT0	C22	E2		
--------	-----	-----	----	-----	----	-----	-----	-----	-----	-----	-----	-----	----	--	--

**Display**

7245B	SH1	AH1	T2	L1	SR1	RL0	PP2	DC1	DT0						
7225A/	SH1	AH1	T2	L1	SR1	RL0	PP2	DC1	DT0						
7310A	SH1	AH2	T2	L1	SR1	RL0	PP2	DC1	DT0						
5150A	SH0	AH1	T0	L1	SR0	RL0	PP0	DC0	DT0	C0	E1	Opt	001		

**HP-IB**

37201A	SH1	AH1	T6	L4	TE0	SR1	RL0	PP0	DC0	DT0	C	E1			
37203A	NOT APPLICABLE														





